



<i>Title:</i> NEON Preventive Maintenance Procedure: Radiation Sensors		<i>Date:</i> 04/12/2022
<i>NEON Doc. #:</i> NEON.DOC.004429	<i>Author:</i> R. Zulueta, M. Cavileer, R. Willingham	<i>Revision:</i> C

## NEON PREVENTIVE MAINTENANCE PROCEDURE: RADIATION SENSORS

PREPARED BY	ORGANIZATION	DATE
Rommel C. Zulueta	FIU	04/30/2018
Madeline Cavileer	ENG	07/22/2021
Rachael Willingham	ENG	03/28/2018

APPROVALS	ORGANIZATION	APPROVAL DATE
Kate Thibault	SCI	04/12/2022

RELEASED BY	ORGANIZATION	RELEASE DATE
Tanisha Waters	CM	04/12/2022

See configuration management system for approval history.



<i>Title:</i> NEON Preventive Maintenance Procedure: Radiation Sensors		<i>Date:</i> 04/12/2022
<i>NEON Doc. #:</i> NEON.DOC.004429	<i>Author:</i> R. Zulueta, M. Cavileer, R. Willingham	<i>Revision:</i> C

## Change Record

<b>REVISION</b>	<b>DATE</b>	<b>ECO #</b>	<b>DESCRIPTION OF CHANGE</b>
A	05/01/2018	ECO-05573	Initial release
B	08/02/2021	ECO-06656	Removing offensive terminologies and updating NEON branding.
C	04/12/2022	ECO-06798	<ul style="list-style-type: none"><li>Update to reflect change in terminology from relocatable to gradient sites.</li></ul>



Title: NEON Preventive Maintenance Procedure: Radiation Sensors		Date: 04/12/2022
NEON Doc. #: NEON.DOC.004429	Author: R. Zulueta, M. Cavileer, R. Willingham	Revision: C

**TABLE OF CONTENTS**

**1 DESCRIPTION..... 1**

1.1 Purpose..... 1

1.2 Scope..... 1

**2 RELATED DOCUMENTS AND ACRONYMS..... 3**

2.1 Applicable Documents ..... 3

2.2 Reference Documents ..... 4

2.3 External References..... 5

2.4 Acronyms ..... 7

2.5 Terminology..... 8

**3 SAFETY AND TRAINING .....10**

3.1 Hazard Communication Safety Data Sheets (SDS).....10

**4 SENSOR OVERVIEW .....11**

4.1 TIS South East and South West Radiation.....11

4.2 Net Radiometer.....11

4.2.1 External Components .....11

4.2.2 Description .....11

4.2.3 Sensor Specific Handling Precautions .....13

4.2.4 Operation .....13

4.3 Primary Pyranometer .....14

4.3.1 External Components .....14

4.3.2 Internal Components.....14

4.3.3 Description .....14

4.3.4 Sensor Specific Handling Precautions .....19

4.3.5 Operation .....19

4.4 Sunshine Pyranometer.....19

4.4.1 External Components .....19

4.4.2 Internal Components.....19

4.4.3 Description .....19

4.4.4 Sensor Specific Handling Precautions .....25

4.4.5 Operation .....25



Title: NEON Preventive Maintenance Procedure: Radiation Sensors		Date: 04/12/2022
NEON Doc. #: NEON.DOC.004429	Author: R. Zulueta, M. Cavileer, R. Willingham	Revision: C

4.5 Biological Temperature Sensor.....25

    4.5.1 External Components .....25

    4.5.2 Description .....25

    4.5.3 Sensor Specific Handling Precautions .....31

    4.5.4 Operation .....31

4.6 PAR Quantum Sensor .....32

    4.6.1 External Components .....32

    4.6.2 Description .....32

    4.6.3 Sensor Specific Handling Precautions .....34

    4.6.4 Operation .....34

4.7 Quantum Line Sensor .....34

    4.7.1 External Components .....34

    4.7.2 Description .....35

    4.7.3 Sensor Specific Handling Precautions .....38

    4.7.4 Operation .....38

**5 INSPECTION AND PREVENTIVE MAINTENANCE .....39**

    5.1 Preventative Maintenance Procedural Sequence .....39

    5.2 Preventive Maintenance Schedule.....39

    5.3 Equipment .....41

    5.4 Subsystem Location and Access.....42

    5.5 Maintenance Procedure.....42

        5.5.1 Common Cleaning Procedures .....43

        5.5.2 Specific Conditions Cleaning Procedures (SCCP).....44

        5.5.3 Sensor Specific Maintenance Procedures.....47

        5.5.4 Leveling.....57

        5.5.5 Mounting Nuts and Bolts.....57

**6 REMOVAL AND REPLACEMENT (SUBSYSTEM ONLY).....59**

    6.1 Equipment .....59

    6.2 Removal and Replacement Procedure.....60

    6.3 TIS Radiation Sensor Removal and Replacement Procedures .....62

        6.3.1 TIS Tower Radiation Sensors.....62



Title: NEON Preventive Maintenance Procedure: Radiation Sensors		Date: 04/12/2022
NEON Doc. #: NEON.DOC.004429	Author: R. Zulueta, M. Cavileer, R. Willingham	Revision: C

6.3.2 TIS Soil Array Radiation Sensors .....77

6.4 AIS Radiation Sensor Removal and Replacement Procedures.....81

6.4.1 AIS Aquatic Met Station Radiation Sensors.....81

6.4.2 AIS Stream Radiation Sensors .....86

6.4.3 AIS Buoy Radiation Sensors .....89

6.5 Grape Removal and Replacement Procedure .....95

6.6 Cleaning & Packaging of Returned Sensor.....97

6.7 Sensor Refresh Record Management of Assets..... 103

6.7.1 NEON Asset Management and Logistic Tracking System Requirements ..... 103

**7 ISSUE REPORTING OUTPUTS ..... 105**

**8 APPENDIX ..... 107**

8.1 List of all NEON TIS Sites..... 108

8.2 List of All NEON AIS Sites..... 110

8.3 TIS Core Tower Sites..... 111

8.4 AIS Met Station Sites ..... 112

8.5 AIS Lake Buoy Sites..... 113

8.6 Heated and Extreme-Heated TIS Site List..... 114

8.7 Heated and Extreme-Heated AIS Site List..... 115

8.8 How to Power Down a Tower Measurement Level (ML)..... 116

8.9 How to Power Down an AIS Device Post: Aquatic Met Station ..... 117

8.10 How to Power Down a Soil Plot (SP) Power Box ..... 119

8.11 How to Power Down an AIS Device Post: Stream Combo Box..... 121

**9 SOURCES..... 124**

**LIST OF TABLES AND FIGURES**

Table 1. Radiation Agile Sensor Name, Make and Model..... 1

Table 2. Preventive Maintenance Frequency and Schedule. ....39

Table 3. Tools, Consumables, and Resource Lists for Preventive Maintenance.....41

Table 4. Installation Locations of Radiation Sensors at TIS and AIS Sites. ....42

Table 5. TIS and AIS Radiation Sensors that are serviced with the Common Cleaning Procedure (CCP)...42

Table 6. TIS and AIS PAR sensors serviced with the Modified Common Cleaning Procedure (MCCP) for PAR sensors. ....43



Title: NEON Preventive Maintenance Procedure: Radiation Sensors		Date: 04/12/2022
NEON Doc. #: NEON.DOC.004429	Author: R. Zulueta, M. Cavileer, R. Willingham	Revision: C

Table 7. Removal and Replacement Equipment List.....59

Table 8. Radiation Sensor Refresh Requirements. ....61

Table 9. Tower Profile ML Net Radiometer, PAR Quantum Sensor Removal and Replacement Procedure | TIS Tower.....63

Table 10. Tower Top ML Net Radiometer, PAR Quantum Sensor, Primary Pyranometer, and Sunshine Pyranometer Removal and Replacement Procedure |TIS Tower .....68

Table 11. Quantum Line Sensor, Net Radiometer and Biological Temperature Sensor Removal and Replacement Procedure |TIS Soil Array. ....78

Table 12. Net Radiometer and PAR Quantum Sensor Removal and Replacement Procedure | Aquatic Met Station.....82

Table 13. PAR Quantum Sensors Removal and Replacement Procedure | AIS Stream Anchor (S-1/S-2) .87

Table 14. Net Radiometer and PAR Quantum Sensor Removal/Replacement | AIS Buoy.....90

Table 15. Grape Verification TEP Commands (e.g., PuTTY).....97

Table 16. Radiation Sensor Packaging Requirements. ....97

Table 17. Metadata Output Checklist. ....105

Table 18. List of all NEON TIS sites including Domain, Site ID, Name, and Site Type. ....108

Table 19. List of all NEON AIS sites including Domain, Site ID, Name, and Site Type.....110

Table 20. List of TIS Core Tower Sites. ....111

Table 21. List of AIS Met Station Sites.....112

Table 22. List of AIS Lake Buoy Sites.....113

Table 23. List of TIS Heated and Extreme-Heated Sites. ....114

Table 24. List AIS Heated and Extreme-Heated Sites.....115

**Figure 1.** Net Radiometer minus the solar shields. ....12

**Figure 2.** Net Radiometer with solar shields.....12

**Figure 3.** Head-on view of the Net Radiometer with solar shields.....13

**Figure 4.** Physical differences between the pyrgeometer (flat surface), and the pyranometer (domed surface).....13

**Figure 5.** Primary Pyranometer minus the solar shield and ventilator. ....15

**Figure 6.** Cross-sectional diagram of the Primary Pyranometer and associated components. ....15

**Figure 7.** Primary Pyranometer with Solar Shield and Ventilator Cover. ....16

**Figure 8.** Primary Pyranometer with Solar Shield and Ventilator Cover Removed. ....16

**Figure 9.** Side view of Ventilator Base. ....17

**Figure 10.** Close up of the clear desiccant canister and indicating desiccant attached to the side of the Primary Pyranometer. ....17

**Figure 11.** Underside of the Primary Pyranometer showing the Ventilator Fan. A fan cover with a screen and filter are attached (see **Figure 12**).....18

**Figure 12.** Fan Filter, Filter Screen, and Fan Cover.....18

**Figure 13.** Overview photo of the Sunshine Pyranometer .....20

**Figure 14.** Side view of the Sunshine Pyranometer.....21

**Figure 15.** Computer generated depiction of the Sunshine Pyranometer’s Shadow Mask. ....21



Title: NEON Preventive Maintenance Procedure: Radiation Sensors		Date: 04/12/2022
NEON Doc. #: NEON.DOC.004429	Author: R. Zulueta, M. Cavileer, R. Willingham	Revision: C

**Figure 16.** Top view of the Sunshine Pyranometer. ....22

**Figure 17.** Cross-sectional view of the Sunshine Pyranometer. ....22

**Figure 18.** Side view showing locations of the two cable connectors.....23

**Figure 19.** Side view showing location of the desiccant canister humidity indicator window.....23

**Figure 20.** Close up of the Humidity Indicator Window on the Desiccant Canister. The numbers indicate 30% and 50% relative humidity (RH). ....24

**Figure 21.** Sunshine Pyranometer mounted atop a TIS Tower.....24

**Figure 22.** Side overview photo of the Biological Temperature Sensor .....26

**Figure 23.** Rear overview photo of a standard Biological Temperature Sensor .....27

**Figure 24.** Rear overview photo of the soil plot and ML1 Biological Temperature Sensor.....27

**Figure 25.** Front view of the Biological Temperature Sensor. ....28

**Figure 26.** Head-on view of the Biological Temperature Sensor.....28

**Figure 27.** Biological Temperature Sensor and radiation shield dimensions.....29

**Figure 28.** Biological Temperature Sensor and associated TPE jacketed cabling and connectors.....29

**Figure 29.** Biological Temperature Sensor and associated stainless steel braided cabling and connectors. ....30

**Figure 30.** Biological Temperature Sensor mounted 22° from vertical .....30

**Figure 31.** Biological Temperature Sensor mounted on ML1 along with other sensors.....31

**Figure 32.** Side overview photo of the PAR Quantum Sensor. ....32

**Figure 33.** Opposite side overview of the PAR Quantum Sensor. ....33

**Figure 34.** Side overview showing the water drain hole. ....33

**Figure 35.** PAR Quantum Sensor mounted on ML1 on the TIS Tower. ....34

Figure 36. Overview photo of the Quantum Line Sensor .....35

**Figure 37.** Close-up of the connector end of the Quantum Line Sensor. ....36

**Figure 38.** Close-up of the “cone” end of the Quantum Line Sensor. ....36

**Figure 39.** Extreme close-up showing the white silicone seal surrounding the diffuser. ....37

**Figure 40.** Quantum Line Sensor installed underneath some vegetation within a soil plot.....37

**Figure 41.** Quantum Line Sensor installed within a soil plot. ....38

Figure 42. The vertical edge of the PAR Quantum Sensor light diffuser.....56

Figure 43. Tower Profile ML Radiation Booms/Arbor: Biological Temperature Sensor (SI-111) and PAR Quantum Sensor (PQS1) .....63

Figure 44. ML1 Profile Radiation and Biological Temperature Sensor Combo.....63

Figure 45. Subsystem Concord Grape on Profile Boom Arm.....64

Figure 46. Remove PAR Quantum Sensor with 5/32” Allen Wrench .....64

Figure 47. 5/32” Allen Wrench.....64

Figure 48. Remove U-Bolts with Speed Wrench.....65

Figure 49. PAR Quantum Sensor Leveling Plate and Mount Components.....65

Figure 50. Inclinometer on the PAR Quantum Sensor Leveling Plate (D08 DELA).....66

Figure 51. Initial Extension Measurement.....66

Figure 52. Initial Retraction Measurement.....67

Figure 53. Initial Retraction – Initial Extraction = DELTA Offset Measurement .....67



Title: NEON Preventive Maintenance Procedure: Radiation Sensors		Date: 04/12/2022
NEON Doc. #: NEON.DOC.004429	Author: R. Zulueta, M. Cavileer, R. Willingham	Revision: C

Figure 54. Desired DELTA Offset Measurement = Digital Level Measurement for PAR Leveling Plate .....67

Figure 55. Tower Top ML Combined Boom Arm with Net Radiometer & PAR Quantum Sensor (D08 DELA) and Railing with the Primary Pyranometer and Sunshine Pyranometer (D08 TALL) .....68

Figure 56. Tower Top ML Combined Boom Radiation Sensor Subsystem Grapes (D06 KONA) .....69

Figure 57. Tower Top ML Railing Radiation Sensor Merlot Grapes (D08 TALL/D19 HEAL) .....69

Figure 58. Remove the Primary Pyranometer from Mount Plate .....69

Figure 59. Use Flathead Screwdriver to Solar Shield .....70

Figure 60. Remove SPN1 Sensor from Mount Plate .....70

Figure 61. Components in Order of Operation to Retract the Tower Top Boom .....71

Figure 62. Remove the First Pin from the Longer Boom Arm.....71

Figure 63. Remove the Second Pin from the Crossbeam (D06).....71

Figure 64. Move Crossbeam Toward Tower Top Railing .....72

Figure 65. Guide the Boom Arm Toward the Tower Top (D06 KONA) .....72

Figure 66. Tower Top Radiation Boom Pivoting Toward Tower Deck.....73

Figure 67. Mechanical Stop for Boom (D02 BLAN).....73

Figure 68. Crossbeam Thumbscrew .....73

Figure 69. Rotate Assembly Toward Tower Top Railing/Deck.....74

Figure 70. Remove the Two Screws for Each PAR Sensor (Source: AD [21]) .....74

Figure 71. Primary Pyranometer Yellow Cables (CVAL).....75

Figure 72. Sunshine Pyranometer Leveling Components & Ground Strap (D19 HEAL).....75

Figure 73. Sensor Leveling for Net Radiometer and PAR Sensor .....76

Figure 74. Level the Net Radiometer and PAR Quantum Sensors using the Inclinator (D08 DELA) .....77

Figure 75. Radiation Arbor with Merlot Grape, Net Radiometer (CF05930000) and Biological Temperature Sensor (CF05940000) in Soil Plot 3 (D14 JORN).....78

Figure 76. A Quantum Line Sensor (CF05840000) in Soil Plot 3 (D08 TALL).....78

Figure 77. Radiation Arbor (D14 JORN).....79

Figure 78. CF00500000 Assy, Quantum Line Sensor Mount .....80

Figure 79. AIS Aquatic Met Station Radiation Boom Arm with PAR Quantum Sensor and Net Radiometer (D14 SYCA).....81

Figure 80. Aquatic Met Station Radiation Boom (D18 OKSR).....82

Figure 81. PAR Quantum Sensor and Net Radiometer Merlot Grape (12V).....82

Figure 82. Remove PAR Quantum Sensor from Aquatic Met Station .....83

Figure 83. Remove Set Screws to Remove Net Radiometer .....83

Figure 84. Net Radiometer Splitter Box .....83

Figure 85. Removing the Net Radiometer.....84

Figure 86. PAR Quantum Sensor and U-Bolt Mount Components .....84

Figure 87. PAR Quantum Sensor Leveling Infographic for Aquatic Met Station (D18 OKSR on Right) (Source: RD [05]) .....85

Figure 88. Net Radiometer Leveling Axes (Source: RD [06] and RD [05]) .....86

Figure 89. PAR Quantum Sensor on S-1/S-2 Anchor (D18 OKSR).....87

Figure 90. Downstream Sensor Set (S-2) (D18 OKSR) .....87





Title: NEON Preventive Maintenance Procedure: Radiation Sensors		Date: 04/12/2022
NEON Doc. #: NEON.DOC.004429	Author: R. Zulueta, M. Cavileer, R. Willingham	Revision: C

Figure 91. Grape (12V) High-Water Installation (D06 KING).....88

Figure 92. Remove PAR Quantum Sensor from Stream Anchor (D18 OKSR) .....88

Figure 93. PAR Quantum Sensor and Primary Pyranometer Leveling Infographic .....89

Figure 94. PAR Quantum Sensor Merlot Grape (12V).....89

Figure 95. AIS Buoy Radiation Boom: Net Radiometer and PAR Quantum Sensor .....90

Figure 96. Unlatch to Remove Fiberglass T-Frame Covers (D09 PRPO).....90

Figure 97. Profile Canister Port Mapping (Source: AD [10]) .....91

Figure 98. Met Canister Port Mapping (Source: AD [10]) .....91

Figure 99. Radiation Boom U-Bolt Mount to Mast.....92

Figure 100. Radiation Sensor Winterization (D18 TOOL) .....92

Figure 101. Remove the PAR Quantum Sensor from the Radiation Boom .....93

Figure 102. Remove the 2 Setscrews and Lift Retention Clip.....93

Figure 103. Net Radiometer Splitter on AIS Buoy on T-Frame .....94

Figure 104. AIS Buoy Radiation Boom Arm: Net Radiometer and PAR Quantum Sensor with Black Caps over the Sensor Diffusers.....94

Figure 105. Re-dress Sensor Cables with Zip Ties (D03 FLNT).....95

Figure 106. Grape Mount Clamps to Unistrut and Pipe Infrastructure Examples (D14 JORN/D18 TOOK).96

Figure 107. Primary Pyranometer.....98

Figure 108. Primary Pyranometer Screen Requires Cleaning.....98

Figure 109. Sunshine Pyranometer .....99

Figure 110. Biological Temperature Sensor Assemblies.....99

Figure 111. Decontaminate Shield.....99

Figure 112. Incorrect Way to Package Sensors for Sensor Refresh..... 100

Figure 113. Biological Temperature Sensor Requires Cable Strain Relief – Use Zip Ties to Prevent Straining the Cable if the Sensor has No Connector..... 100

Figure 114. Biological Temperature Sensor must have these Components Post-Decontamination ..... 101

Figure 115. PAR Quantum Sensor with Black Cap over Diffuser..... 101

Figure 116. Net Radiometer with Black Caps over the sensors. .... 102

Figure 117. Cap Cables..... 102

Figure 118. Soil Quantum Line Sensor (QLS) ..... 102

Figure 119. Red Rejected Tag for Defective Assets (MX104219). .... 106

Figure 120. How to Power Down a Tower ML..... 116

Figure 121. AIS Device Post: Power Box Components (Domain 18 OKSR AIS Aquatic Met Station). .... 118

Figure 122. AIS Device Post: Comm Box Heater Ports for Aspirated Temperature Shield (ATS) and 2D Wind (Source: AD [10]). .... 119

Figure 123. Open Soil Plot Device Post Power Box..... 120

Figure 124. Soil Plot Device Post: Flip 5 Amp Breakers (Location: D08 TALL)..... 121

Figure 125. AIS Device Post: Combo Box Power Components (Domain 18 OKSR AIS S1/S2). .... 122



Title: NEON Preventive Maintenance Procedure: Radiation Sensors		Date: 04/12/2022
NEON Doc. #: NEON.DOC.004429	Author: R. Zulueta, M. Cavileer, R. Willingham	Revision: C

## 1 DESCRIPTION

### 1.1 Purpose

The National Ecological Observatory Network (NEON) employs terrestrial and aquatic sensors to collect measurements from air, wind, soil, sun, and water across the United States (to include Alaska, Hawaii and Puerto Rico). Regular maintenance of these sensors and their infrastructure is necessary for the continued operation of the observatory and identify problems before they escalate.

This document details the procedures necessary for the preventive maintenance of the **Radiation Sensors (Table 1)**.

### 1.2 Scope

Preventive Maintenance is the planned maintenance of infrastructure and equipment with the goal of improving equipment life by preventing excess depreciation and impairment. This maintenance includes, but is not limited to, inspecting, adjusting, cleaning, clearing, lubricating, repairing, and replacing, as appropriate. The procedures in this document are strictly preventive.

This document specifically addresses the preventive procedures to maintain the **Radiation Sensors** for the NEON Project’s Terrestrial Instrument System (TIS) and Aquatic Instrument System (AIS) sites. This covers the instrumentation, subsystem and infrastructure for radiation sensors listed in **Table 1**.

**Table 1. Radiation Agile Sensor Name, Make and Model.**

Agile Subsystem or Sensor Assembly Number	Sensor Name	Make	Model
<ul style="list-style-type: none"> <li>CF05930000 Subsystem, Soil Radiation LW IR</li> <li>CD05920000 Subsystem, South West Radiation, Split or Non-Heated Combined, PAR Right</li> <li>CD05920020 Subsystem, South West Radiation, Split or Non-Heated Combined, PAR Left</li> <li>CD05920020 Subsystem, South West Radiation, Split or Non-Heated Combined, PAR Left</li> <li>CD05920030 Subsystem, South West Radiation, Heated, Combined, PAR Left</li> <li>0349250000 Sensor, Buoy, Net Radiation, NR01</li> <li>HA05920000 Subsystem, Net Radiation SW/LW, Aquatic Met Station</li> </ul>	Net Radiometer	Hukseflux	NR01
<ul style="list-style-type: none"> <li>CD05910000 Subsystem, South East Radiation, Core</li> <li>CD05910010 Subsystem, South East Radiation, Single</li> <li>CD05910020 Subsystem, South East Radiation, Core, Wind River</li> </ul>	Primary Pyranometer	Kipp & Zonen	CMP22
	Sunshine Pyranometer	Delta-T	SPN1
<ul style="list-style-type: none"> <li>CD05870000 Subsystem, Mid-Level Radiation, Split, Lower</li> <li>CF05940000 Subsystem, Soil Radiation IR Broadband</li> </ul>	Biological Temperature	Apogee	SI-111



Agile Subsystem or Sensor Assembly Number	Sensor Name	Make	Model
<ul style="list-style-type: none"> <li>• CD0587000 Subsystem, Mid-Level Radiation, Split, Lower</li> <li>• HA05870000 Subsystem, Surface Radiation, Aquatic Met Station</li> <li>• CD05920000 Subsystem, South West Radiation, Split or Non-Heated Combined, PAR Right</li> <li>• CD05920010 Subsystem, South West Radiation, Heated, Combined, PAR Right</li> <li>• HB06600000 Subsystem, Sensor Infrastructure, Stream, Sand</li> <li>• HB06600010 Subsystem, Sensor Infrastructure, Stream, Bedrock</li> <li>• 0348420000 Sensor, Buoy, PAR, PQS-1</li> </ul>	PAR Quantum	Kipp & Zonen	PQS1
<ul style="list-style-type: none"> <li>• CF05840000 Subsystem, Soil Radiation Quantum Line Sensor</li> </ul>	Quantum Line Sensor	LI-COR	LI-191

This procedure does not include the underwater PAR (uPAR) sensor. See RD [13] for comprehensive information on the uPAR radiation sensor.



Title: NEON Preventive Maintenance Procedure: Radiation Sensors		Date: 04/12/2022
NEON Doc. #: NEON.DOC.004429	Author: R. Zulueta, M. Cavileer, R. Willingham	Revision: C

## 2 RELATED DOCUMENTS AND ACRONYMS

### 2.1 Applicable Documents

The following applicable documents (AD) contain mandatory requirements and/or supplementary information that are directly applicable to the topic and/or procedures herein. Visit the [NEON Document Warehouse](#) for electronic copies of these documents.

AD [01]	NEON.DOC.004300	NEON Environmental, Health, Safety And Security (EHSS) Policy, Program And Management Plan
AD [02]	NEON.DOC.004301	NEON Environmental, Health, Safety and Security (EHSS) Environmental Protection Manual
AD [03]	NEON.DOC.004316	Operations Field Safety and Security Plan
AD [04]	NEON.DOC.050005	Field Operations Job Instruction Training Plan
AD [05]	NEON.DOC.004257	NEON Standard Operating Procedure (SOP): Decontamination of Sensors, Field Equipment and Field Vehicles
AD [06]	NEON.DOC.002768	TIS Subsystem Architecture, Site Configuration and Subsystem Demand by Site - SCMB Baseline
AD [07]	NEON.DOC.002767	AIS Subsystem Architecture, Site Configuration and Subsystem Demand by Site - SCMB Baseline
AD [08]	NEON.DOC.001427	TIS Hut, Rack DAS and PDS Interconnect
AD [09]	NEON.DOC.001436	TIS Comm Interconnect Mapping
AD [10]	NEON.DOC.001972	AIS Comm Interconnect Mapping
AD [11]	NEON.DOC.004886	NEON Preventive Maintenance Procedure: Aquatic Portal & AIS Device Posts
AD [12]	NEON.DOC.000527	NEON Installation Procedure: South East Radiation
AD [13]	NEON.DOC.000529	NEON Installation Procedure: South West Radiation
AD [14]	NEON.DOC.004665	Surface Radiation Formal Verification Procedure
AD [15]	NEON.DOC.004483	Surface Radiation: Met Station and Tower Formal Verification Procedures
AD [16]	NEON.DOC.004452	South East Radiation Formal Verification Procedures
AD [17]	NEON.DOC.004467	Soil Radiation IR Broadband Formal Verification Procedures
AD [18]	NEON.DOC.004465	Soil Radiation Quantum Line Sensor Formal Verification Procedures
AD [19]	NEON.DOC.004466	Soil Radiation LW IR Formal Verification Procedures
AD [20]	NEON.DOC.004717	TIS Soil Plot Radiation Arbor Formal Verification Procedures
AD [21]	NEON.DOC.001326	Procedure, Assembly, PAR and Inclinator Top Level
<b>Net Radiometer (NR01)</b>		
AD [22]	NEON.DOC.000809	NEON Algorithm Theoretical Basis Document (ATBD) - Net Radiometer
AD [23]	NEON.DOC.000418	NEON Sensor Command, Control and Configuration – Net Radiometer
AD [24]	NEON.DOC.000778	NEON Sensor Command, Control and Configuration – Soil Longwave Radiation



Title: NEON Preventive Maintenance Procedure: Radiation Sensors		Date: 04/12/2022
NEON Doc. #: NEON.DOC.004429	Author: R. Zulueta, M. Cavileer, R. Willingham	Revision: C

<b>Primary Pyranometer (CMP22)</b>		
AD [25]	NEON.DOC.000810	NEON Algorithm Theoretical Basis Document (ATBD) – Primary Pyranometer
AD [26]	NEON.DOC.000549	NEON Sensor Command, Control and Configuration – Primary Shortwave Radiation
<b>Sunshine Pyranometer (SPN1)</b>		
AD [27]	NEON.DOC.000815	Algorithm Theoretical Basis Document (ATBD) - Global, Direct and Diffuse Radiation
AD [28]	NEON.DOC.000610	NEON Sensor Command, Control and Configuration – Direct and Diffuse Shortwave Radiation
<b>Biological Temperature (SI-111)</b>		
AD [29]	NEON.DOC.000652	NEON Algorithm Theoretical Basis Document (ATBD) – Biological Temperature
AD [30]	NEON.DOC.000417	NEON Sensor Command, Control and Configuration – Biological Temperature
AD [31]	NEON.DOC.000609	Soil Radiation Biological Temperature Sensor Command, Control and Configuration Document
<b>PAR Quantum Sensor (PQS1)</b>		
AD [32]	NEON.DOC.000781	NEON Algorithm Theoretical Basis Document (ATBD) – Photosynthetically Active Radiation
AD [33]	NEON.DOC.000416	NEON Sensor Command, Control and Configuration – Photosynthetically Active Radiation (PAR)
<b>Quantum Line Sensor (LI-191)</b>		
AD [34]	NEON.DOC.000813	NEON Algorithm Theoretical Basis Document (ATBD) – Quantum Line Sensor
AD [35]	NEON.DOC.000603	NEON Sensor Command, Control and Configuration – Quantum Line Sensor

## 2.2 Reference Documents

The Reference Documents (RD) listed below may provide complimentary information to support this procedure. Visit the [NEON Document Warehouse](#) for electronic copies of these documents.

RD [01]	NEON.DOC.000008	NEON Acronym List
RD [02]	NEON.DOC.000243	NEON Glossary of Terms
RD [03]	NEON.DOC.000705	NEON Bolt Torque Specifications
RD [04]	NEON.DOC.000769	Electrostatic Discharge Prevention Procedure
RD [05]	NEON.DOC.004821	NEON Preventive Maintenance Procedure: Aquatic Meteorological (Met) Station
RD [06]	NEON.DOC.001637	Aquatic Met Station Installation Procedure
RD [08]	NEON.DOC.004613	NEON Preventive Maintenance Procedure: AIS Buoy



Title: NEON Preventive Maintenance Procedure: Radiation Sensors		Date: 04/12/2022
NEON Doc. #: NEON.DOC.004429	Author: R. Zulueta, M. Cavileer, R. Willingham	Revision: C

RD [09]	NEON.DOC.003880	NEON Preventive Maintenance Procedure: AIS Stream Infrastructure
RD [10]	NEON.DOC.004638	AIS Verification Checklist
RD [11]	NEON.DOC.004637	TIS Verification Checklist
RD [12]	NEON.DOC.004574	NEON Installation, Operation & Maintenance Procedure: Mobile Deployment Platform (MDP) Instrument Hut and Tower Systems
RD [13]	NEON.DOC.002757	NEON Preventive Maintenance Procedure: AIS Underwater Photosynthetically Active Radiation (uPAR)
RD [14]	NEON.DOC.004752	NEON Installation, Operation & Maintenance Procedure: Mobile Deployment Platform (MDP) Aquatics Module
RD [15]	NEON.DOC.003519	How-To: Turn on a Communication Box Relay
RD [16]	NEON.DOC.004886	NEON Preventive Maintenance Procedure: Aquatic Portal & AIS Device Posts
RD [17]	NEON.DOC.000527	NEON Installation Procedure: South East Radiation
RD [18]	NEON.DOC.000529	NEON Installation Procedure: South West Radiation
RD [19]	NEON.DOC.004665	Surface Radiation Formal Verification Procedure
RD [20]	NEON.DOC.004483	Surface Radiation: Met Station and Tower Formal Verification Procedures
RD [21]	NEON.DOC.004452	South East Radiation Formal Verification Procedures
RD [22]	NEON.DOC.004467	Soil Radiation IR Broadband Formal Verification Procedures
RD [23]	NEON.DOC.004465	Soil Radiation Quantum Line Sensor Formal Verification Procedures
RD [24]	NEON.DOC.004466	Soil Radiation LW IR Formal Verification Procedures
RD [25]	NEON.DOC.004608	AIS Buoy Verification Procedures
RD [26]	NEON.DOC.004464	PDS TIS Formal Verification Procedures
RD [27]	NEON.DOC.000779	TIS Soil Plot Layout
RD [28]	NEON.DOC.000804	Site Flora and Fauna Maintenance Plan

### 2.3 External References

The External References (ER) listed below may contain supplementary information relevant to maintaining specific standards and/or commercial products pertaining to the Aspirated Air Temperature. These documents are external to the NEON project and Battelle Ecology. If an issue with a product requires the involvement of the manufacturer, NEON Headquarters (HQ) will contact the manufacturer or provide Field Operations (FOPS) the authority to contact via the [NEON Issue Management System](#).

ER [01]	MSDSOnline (NEON Project Access) <a href="https://msdsmanagement.msdsonline.com/ec04e43d-e72d-4174-9369-c81635eb9493/ebinder/?nas=True">https://msdsmanagement.msdsonline.com/ec04e43d-e72d-4174-9369-c81635eb9493/ebinder/?nas=True</a>
ER [02]	Future Technology Devices International (FTDI) Chip Windows Drivers <a href="http://www.ftdichip.com/FTDrivers.htm">http://www.ftdichip.com/FTDrivers.htm</a>
<b>Net Radiometer (NR01)</b>	
ER [03]	Hukseflux User Manual NR01 / RA01 <a href="https://www.hukseflux.com/sites/default/files/product_manual/NR01_RA01_manual_v1710.pdf">https://www.hukseflux.com/sites/default/files/product_manual/NR01_RA01_manual_v1710.pdf</a>



<b>Primary Pyranometer (CMP22)</b>	
ER [04]	Kipp & Zonen Instruction Manual CMP Series Pyranometer ( <i>English</i> ) <a href="http://www.kippzonen.com/Download/72/Manual-Pyranometers-CMP-series-English">http://www.kippzonen.com/Download/72/Manual-Pyranometers-CMP-series-English</a>
ER [05]	Kipp & Zonen Instruction Manual CMP Series Pyranometer ( <i>Spanish</i> ) <a href="http://www.kippzonen.com/Download/355/Manual-Pyranometers-CMP-series-Spanish">http://www.kippzonen.com/Download/355/Manual-Pyranometers-CMP-series-Spanish</a>
ER [06]	Kipp & Zonen Instruction Sheet – Pyranometers – CMP Series <a href="http://www.kippzonen.com/Download/73/Instruction-Sheet-Pyranometers-CMP-series">http://www.kippzonen.com/Download/73/Instruction-Sheet-Pyranometers-CMP-series</a>
ER [07]	Kipp & Zonen Technical Advise – Desiccant Replacement Interval <a href="http://www.kippzonen.com/Download/902/Technical-Advise-Desiccant-replacement-interval">http://www.kippzonen.com/Download/902/Technical-Advise-Desiccant-replacement-interval</a>
ER [08]	Kipp & Zonen CVF3 Ventilation Unit – Instruction Sheet <a href="http://www.kippzonen.com/Download/246/Instruction-Sheet-Ventilation-Unit-CVF3">http://www.kippzonen.com/Download/246/Instruction-Sheet-Ventilation-Unit-CVF3</a>
<b>Sunshine Pyranometer (SPN1)</b>	
ER [09]	Delta-T Sunshine Pyranometer SPN1 – User Manual SPN1-UM-4.1 <a href="https://www.delta-t.co.uk/download/2945/">https://www.delta-t.co.uk/download/2945/</a>
ER [10]	Delta-T Sunshine Pyranometer SPN1 – Datasheet V6 <a href="https://www.delta-t.co.uk/download/2949/">https://www.delta-t.co.uk/download/2949/</a>
ER [11]	Delta-T Sunshine Pyranometer SPN1 – Quick Start Guide v3.0 <a href="https://www.delta-t.co.uk/download/2946/">https://www.delta-t.co.uk/download/2946/</a>
ER [12]	SPN1 Best Practices v3.0 <a href="https://www.delta-t.co.uk/download/2962/">https://www.delta-t.co.uk/download/2962/</a>
<b>Biological Temperature Sensor (SI-111)</b>	
ER [13]	Apogee Infrared Radiometers – Owner’s Manual <a href="https://www.apogeeinstruments.com/content/SI-100-manual.pdf">https://www.apogeeinstruments.com/content/SI-100-manual.pdf</a>
ER [14]	Apogee Infrared Radiometers – Specifications Sheet <a href="https://www.apogeeinstruments.com/content/SI-100-400-spec-sheet.pdf">https://www.apogeeinstruments.com/content/SI-100-400-spec-sheet.pdf</a>
ER [15]	Infrared Radiation (IRR) Shield: More Information <a href="https://www.apogeeinstruments.com/irr-si-radiation-shield-more-information/">https://www.apogeeinstruments.com/irr-si-radiation-shield-more-information/</a>
ER [16]	Protecting Your Instruments from Spiders, Wasps and Other Pests <a href="https://www.apogeeinstruments.com/protecting-your-instruments-from-spiders-wasps-and-other-pests/">https://www.apogeeinstruments.com/protecting-your-instruments-from-spiders-wasps-and-other-pests/</a>
<b>PAR Quantum Sensor (PQS1)</b>	
ER [17]	Kipp & Zonen PAR Quantum Sensor PQS1 – Instruction Sheet <a href="http://www.kippzonen.com/Download/425/Instruction-Sheet-PAR-Quantum-Sensor-PQS1">http://www.kippzonen.com/Download/425/Instruction-Sheet-PAR-Quantum-Sensor-PQS1</a>
ER [18]	Kipp & Zonen PAR Quantum Sensor PQS1 – Brochure in English <a href="http://www.kippzonen.com/Download/429/PQS-1-PAR-Quantum-Sensor-Brochure">http://www.kippzonen.com/Download/429/PQS-1-PAR-Quantum-Sensor-Brochure</a>
<b>Quantum Line Sensor (LI-191)</b>	
ER [19]	LI-COR Terrestrial Radiation Sensors – Instruction Manual <a href="https://www.licor.com/documents/8yfdtw1rs27w93vemwp6">https://www.licor.com/documents/8yfdtw1rs27w93vemwp6</a>



ER [20]	LI-COR LI-191SA Line Quantum Sensor – Brochure <a href="https://www.licor.com/documents/lezc9ms6g103q1nvbjby">https://www.licor.com/documents/lezc9ms6g103q1nvbjby</a>
---------	---

## 2.4 Acronyms

Acronym	Explanation
A/R	As Required
AATS	Aspirated Air Temperature Shield
AIS	Aquatic Instrument Systems
BLAN	Blandy Experimental Farm, Domain 02
CnC	Command and Control
CCP	Common Cleaning Procedure
Comm	Communications
CCP	Common Cleaning Procedure
CVAL	Calibration, Validation and Audit Laboratory
DELA	Dead Lake, Domain 08
DI	Deionized
ECTE	Eddy Covariance Turbulence Exchange
ESD	Electrostatic Discharge
FIR	Far Infrared
FLNT	Flint River, Domain 03
FOPS	Field Operations
FOV	Field of View
GUAN	Guanica Forest, Domain 04
HEAL	Healy, Domain 19
HQ	Headquarters
IR	Infrared
JORN	Jornada LTER, Domain 14
JSA	Job Safety Analysis
KING	Kings Creek, Domain 06
KONA	Konza Prairie Biological Station – Gradient, Domain 06
LC	Location Controller
LED	Light Emitting Diode
LENO	Lenoir Landing, Domain 08
LOGWAR	Logistics Warehouse
LOTO	Lock Out/Tag Out
LW	Longwave
MCCP	Modified Common Cleaning Procedure
MDP	Mobile Deployment Platform
ML	Measurement Level
MLx	Measurement Level where “x” is the level number
NPS	Norminal Piping Size
OKSR	Oksrukuyik Creek, Domain 18
ONAQ	Onaqui-Ault, Domain 13
PAR	Photosynthetically Active Radiation





Title: NEON Preventive Maintenance Procedure: Radiation Sensors		Date: 04/12/2022
NEON Doc. #: NEON.DOC.004429	Author: R. Zulueta, M. Cavileer, R. Willingham	Revision: C

PCB	Printed Circuit Board
PoE	Power over Ethernet
PPE	Personal Protective Equipment
PPFD	Photosynthetic Photon Flux Density
PRPO	Prairie Pothole, Domain 09
QLS	Quantum Line Sensor
QR	Quick Response
RH	Relative Humidity
RTD	Resistance Temperature Detector
SCCP	Specific Conditions Cleaning Procedures
SDS	Safety Data Sheet
SP	Soil Plot
SRER	Santa Rita Experimental Range, Domain 14
SW	Shortwave
SYCA	Sycamore Creek, Domain 14
TALL	Talladega National Forest, Domain 08
TEP	Terminal Emulator Program
TIS	Terrestrial Instrument Systems
TOOL	Toolik, Domain 18
TOOK	Toolik Lake, Domain 18
TPE	Thermoplastic Elastomer
uPAR	Underwater PAR
V	Volt

## 2.5 Terminology

The use of common names for NEON instrumentation and subsystems vary across departments and domains. Equipment, tools, and instrumentation have one technically accurate name, and at times one or more “common” names describing the same item.

This section aims to clarify and associate “common” names with the technical names herein.

<b>SYNONYMOUS AND COMMON NAME(S)</b>	<b>NEON TECHNICAL REFERENCE NAME</b>
Four-Component Net Radiometer, Four-Channel Net Radiometer, Net Radiometer, Net Radiation Sensor, Soil Longwave Radiation Sensor, NR01	Net Radiometer (NR01)
Pyranometer, Shortwave Radiation Sensor, CMP22	Primary Pyranometer (CMP22)
Direct and Diffuse Radiation Sensor, Global Radiation Sensor, Sunshine Sensor, Delta-T, SPN1	Sunshine Pyranometer (SPN1)
Surface Temperature, Infrared Radiometer, Infrared Temperature Sensor, Infrared Thermometer, Apogee, SI-111	Biological Temperature Sensor (SI-111)
Photosynthetically Active Radiation (PAR), PAR Sensor, Quantum Sensor, PQS1	PAR Quantum Sensor (PQS1)



<i>Title:</i> NEON Preventive Maintenance Procedure: Radiation Sensors		<i>Date:</i> 04/12/2022
<i>NEON Doc. #:</i> NEON.DOC.004429	<i>Author:</i> R. Zulueta, M. Cavileer, R. Willingham	<i>Revision:</i> C

<b>SYNONYMOUS AND COMMON NAME(S)</b>	<b>NEON TECHNICAL REFERENCE NAME</b>
Quantum Line Sensor (QLS), Soil Quantum Line Sensor, Line PAR, Surface PAR, LI-191	Quantum Line Sensor (LI-191)



Title: NEON Preventive Maintenance Procedure: Radiation Sensors		Date: 04/12/2022
NEON Doc. #: NEON.DOC.004429	Author: R. Zulueta, M. Cavileer, R. Willingham	Revision: C

### 3 SAFETY AND TRAINING

Personnel working at a NEON site must be compliant with safe fieldwork practices as outlined in AD [01] and AD [04].

The Field Operations Manager and the Lead Field Technician have primary authority to stop work activities based on unsafe field conditions; however, all employees have the responsibility and right to stop their work in unsafe conditions. All technicians must complete required safety training and protocol-specific training for safety and implementation of this protocol as required in AD [04].

Refer to the site-specific EHSS plan(s) and procedure-specific Safety Data Sheet (SDS) via the NEON Project’s account on [MSDSOnline](#) or via the [NEON Safety document portal](#) for electronic copies. Conduct the appropriate Job Safety Analysis (JSA) before conducting any preventive maintenance.

Preventive maintenance of TIS and AIS sensors and infrastructure may require the use of a special equipment to access the sensor subsystem assemblies. Follow Domain site-specific [EHS plans via the Network Drive](#) and NEON safety training procedures when conducting maintenance activities. Conduct a Job safety Analysis (JSA) prior to accessing the sensor subsystems onsite. Reference the [Safety Office SharePoint portal](#) for JSA templates and additional hazard identification information.

***In the event the current methods to conduct the procedures herein are no longer safe for use due to unforeseen or unknown site dynamics, consult with the NEON Safety Office via the NEON Project’s Issue Management and Reporting System (i.e., JIRA or ServiceNow) for alternative methods to conduct TIS and AIS preventive/corrective maintenance and Sensor Refresh procedures.***

#### 3.1 Hazard Communication Safety Data Sheets (SDS)

Safety Data Sheets (SDS)s can always be accessed via the NEON Project’s account on [MSDSOnline](#).

If in the field and have internet connectivity, access to [MSDSOnline](#) can also be accessed via the following Quick Response (QR) code.



Neon Inc.

**Scan to access an  
MSDS**



## 4 SENSOR OVERVIEW

### 4.1 TIS South East and South West Radiation

The designation of “South West” and “South East” are historical and do not reflect positional (based on compass direction) location on the tower; these terms reflect its relative position to the boom supporting them.

- **South West Radiation** is the assembly that holds the:
  - Net Radiometer (NR01)
  - PAR Quantum Sensor (PQS1)
- **South East Radiation** is the assembly that holds the:
  - Primary Pyranometer (CMP22) (at TIS Core sites only)
  - Sunshine Pyranometer (SPN1)

### 4.2 Net Radiometer

#### 4.2.1 External Components

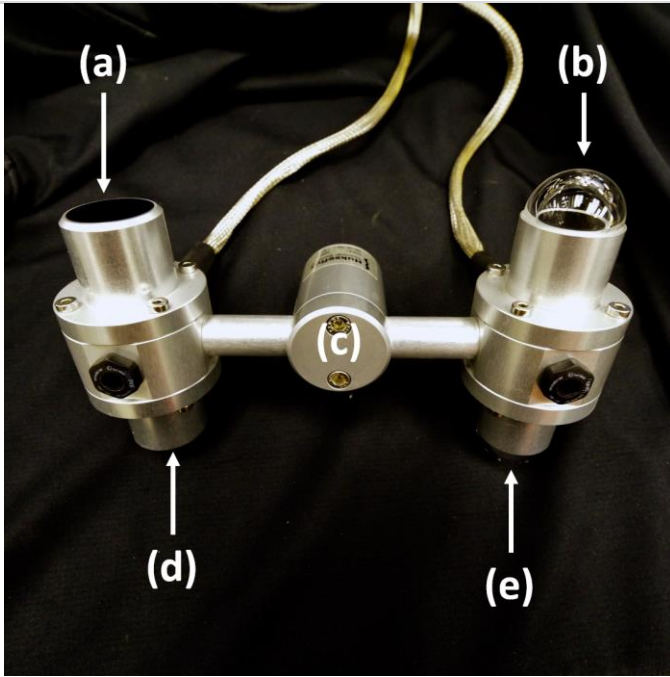
- Hukseflux NR01 Four-Component Net Radiometer
  - Four Solar Radiation Shields
- Concord Grape G4 24V

#### 4.2.2 Description

The Hukseflux NR01 Four-Component Net Radiometer (hereafter referred to as the Net Radiometer) is actually four separate radiometers integrated into an anodized aluminum connection body and mounting assembly (see **Figure 1**). There are two opposing pairs of Hukseflux IR01 Pyrgeometers, and two opposing pairs of Hukseflux SR01 Pyranometers. A white plastic solar radiation shield is attached to each radiometer (see **Figure 2** and **Figure 3**). An embedded PT100 Resistance Temperature Detector (RTD) between the two pyrgeometers, and internal 1-watt heaters for the pyrgeometers are also included.

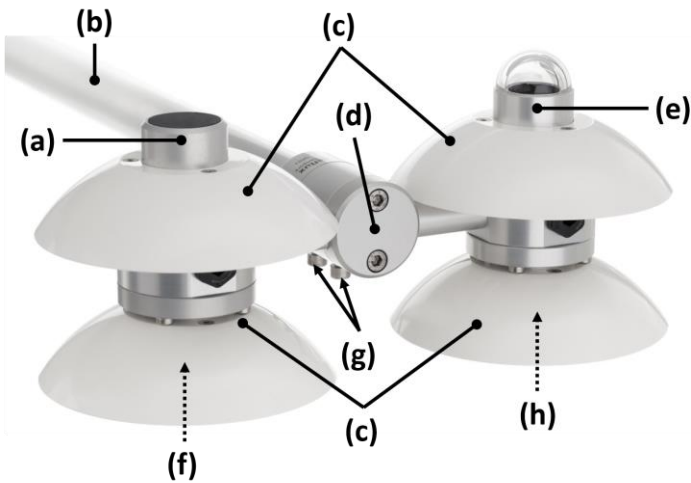
Pyrgeometers measure the longwave (LW) or far infrared (FIR) range of the radiation spectrum (specifically 4500 to 40000 nm) in the atmosphere, while the pyranometers measure the shortwave (SW) of the solar radiation spectrum (specifically 285 to 3000 nm). It is relatively easy to distinguish the two sensors as the pyrgeometers have a flat receptor surface, while the pyranometer has a domed receptor surface (see **Figure 4**).

The Net Radiometer has a mounting assembly for a 3/4 in. Nominal Piping Size (NPS) tube and is held in place on the mounting pipe by two set screw.



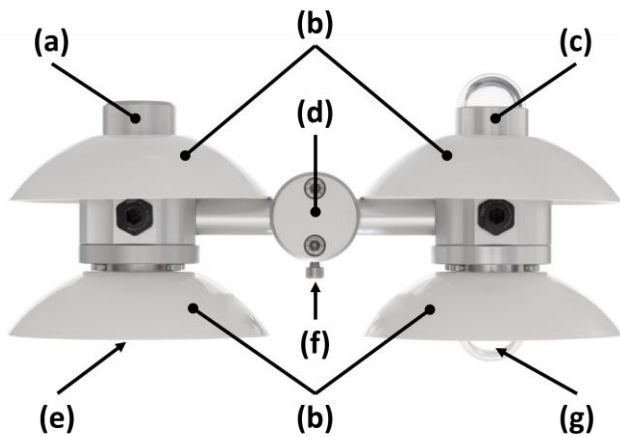
**Figure 1.** Net Radiometer minus the solar shields.

- a) IR01 Pyrgeometer (upward facing)
- b) SR01 Pyranometer (upward facing)
- c) Connection Body and Mounting Assembly
- d) IR01 Pyrgeometer (downward facing)
- e) SR01 Pyranometer (downward facing)



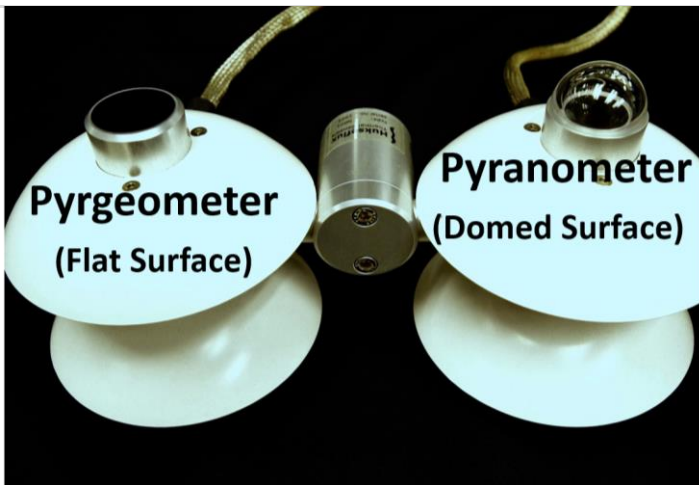
**Figure 2.** Net Radiometer with solar shields.

- a) Pyrgeometer (upward facing)
- b) Mounting Pipe
- c) Solar Radiation Shields
- d) Connection Body and Mounting Assembly
- e) Pyranometer (upward facing)
- f) Pyrgeometer (downward facing)
- g) Mounting Screws
- h) Pyranometer (downward facing)



**Figure 3.** Head-on view of the Net Radiometer with solar shields.

- a) Pyrgeometer (upward facing)
- b) Solar Radiation Shields
- c) Pyranometer (upward facing)
- d) Connection Body and Mounting Assembly
- e) Pyrgeometer (downward facing)
- f) Mounting Screws
- g) Pyranometer (downward facing)



**Figure 4.** Physical differences between the pyrgeometer (flat surface), and the pyranometer (domed surface).

#### 4.2.3 Sensor Specific Handling Precautions

The glass surfaces of each radiometer are easily scratched if cleaned with an abrasive cloth or if there are hardened deposits (e.g. sand, mineral deposits) on the glass surfaces while being cleaned. The glass surfaces and domes can also scratch or break if struck by hard objects, and crack or shatter if dropped.

The plastic solar radiation shields can be broken or become separated from the radiometers during handling and/or shipping.

#### 4.2.4 Operation

Net radiation is the amount of remaining available energy for heating or cooling the soil and air, as well as energy to phase-change water via evaporation, condensation, melting, freezing, or sublimation. An ecosystem's net radiation is essentially the difference of incoming solar energy and outgoing heat energy. Net radiation is a critical measurement since it is the main determinant of climate.



The Net Radiometer uses the four individual radiometers to measure emitted downwelling (i.e. incoming) and emitted upwelling (i.e. outgoing) LW radiation (pyrgeometers), and incoming and reflected SW radiation (pyranometers). Each radiometer has highly sensitive thermopile sensors underneath the flat glass surfaces or domes that measure minute temperature changes in the sensor receptor surface, sensor body, and glass or dome. The outputs of the various thermopile sensors are proportional to the incoming and outgoing SW and LW radiation. The difference between the incoming SW and LW radiation and outgoing SW and LW radiation is then used to calculate the net radiation.

### 4.3 Primary Pyranometer

#### 4.3.1 External Components

- Kipp & Zonen CMP22 Pyranometer
- CVF4 Ventilator
- Grape

#### 4.3.2 Internal Components

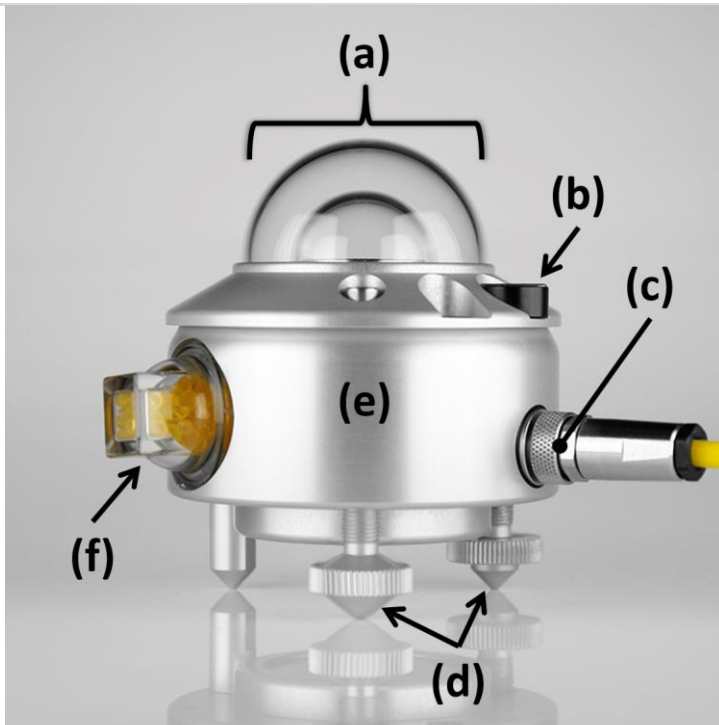
- Desiccant Canister
  - Indicating Desiccant (see **Table 3** for part numbers)

#### 4.3.3 Description

The Kipp & Zonen CMP22 Pyranometer (hereafter referred to as the Primary Pyranometer) is a temperature compensated double-domed pyranometer (see **Figure 5**) that measures incoming SW radiation in the 200 to 3600 nm spectral range. The domes are made of 4mm thick quartz glass that improves the spectral measurement range and reduces directional error. To allow for temperature compensation, there is a PT100 RTD within the body of the pyranometer. There is also a user-serviceable desiccant canister within the body to prevent condensation within the the two quartz glass domes.

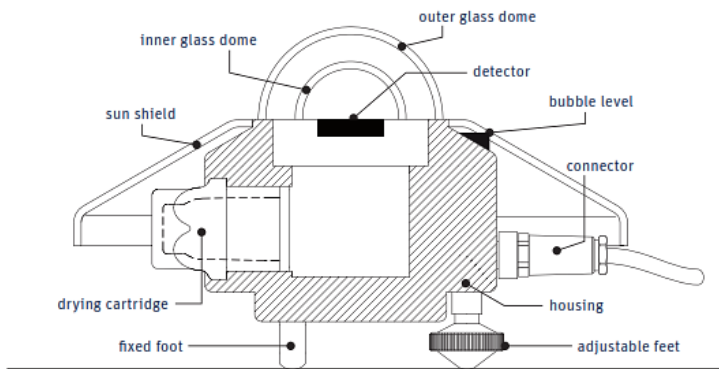
The Primary Pyranometer has an anodized aluminum body with a double-domed upward facing sensor, and a white, aluminum painted solar and ventilator shield. The field of view (FOV) of the pyranometer is 180°.

A Kipp & Zonen CVF3 Ventilator (hereafter just called the Ventilator) encloses the body of the Primary Pyranometer leaving the double quartz domes exposed. The Ventilator improves measurement accuracy by lowering thermal offsets and reduces condensation and dust on the dome. The Ventilator has a 12VDC fan attached to the bottom of the ventilator (see **Figure 12**), and four 10-watt heaters attached to a black “heater plate” at the ventilator base (see **Figure 8**). The fan on the ventilator draws air from the bottom of the ventilator out through the top and over the domes.



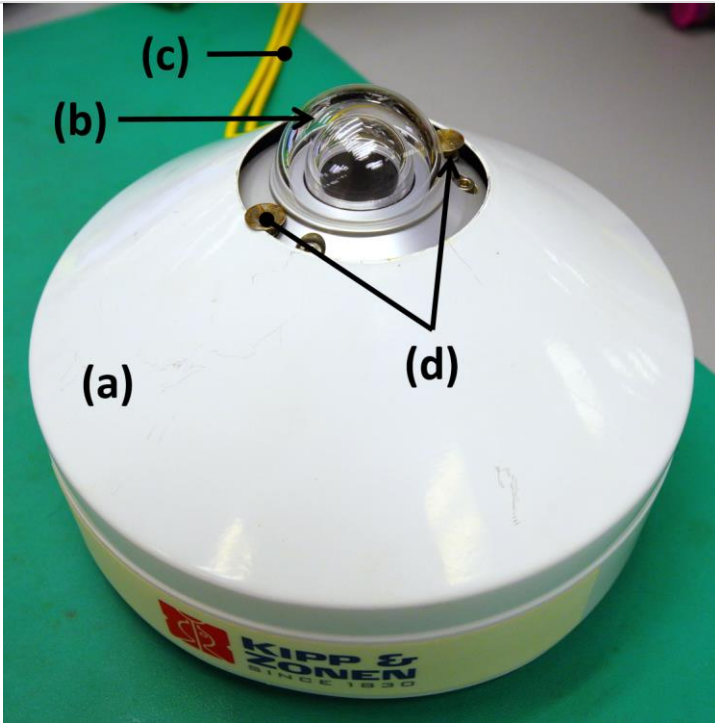
**Figure 5.** Primary Pyranometer minus the solar shield and ventilator.

- a) Double Quartz Glass Domes
- b) Integrated Bubble Level
- c) Cable Connector
- d) Leveling and Mounting Screws
- e) Anodized Aluminum Body
- f) Clear Desiccant Canister



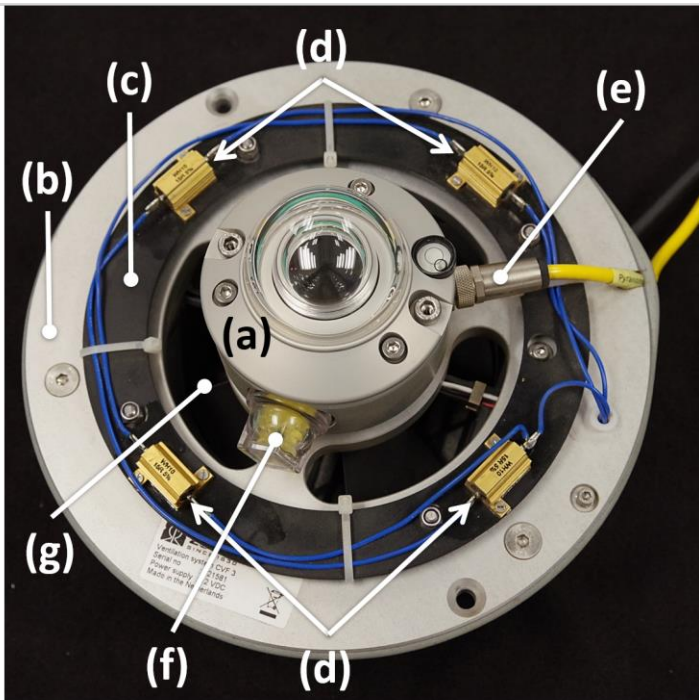
**Figure 6.** Cross-sectional diagram of the Primary Pyranometer and associated components.





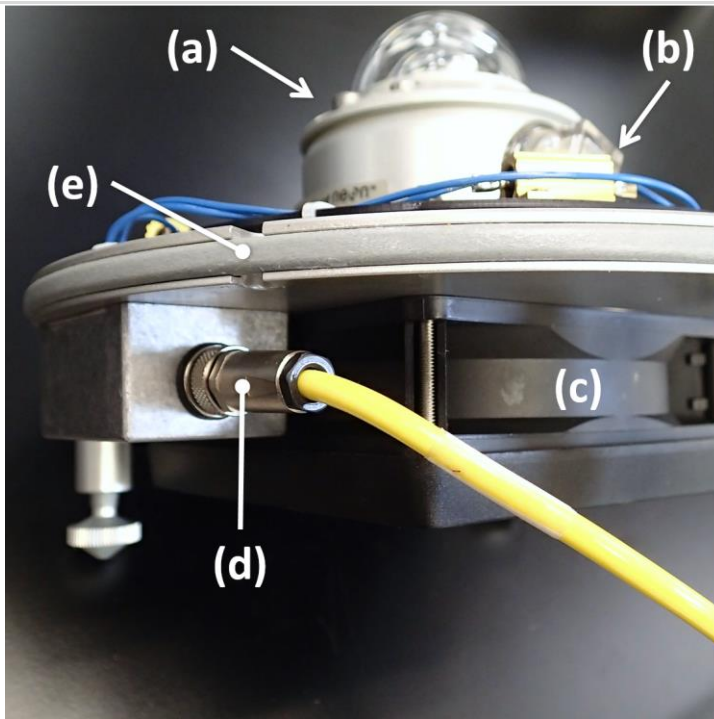
**Figure 7.** Primary Pyranometer with Solar Shield and Ventilator Cover.

- a) Solar Shield and Ventilator Cover
- b) Double Quartz Glass Domes
- c) Power and Signal Cables
- d) Ventilator Retaining Screws



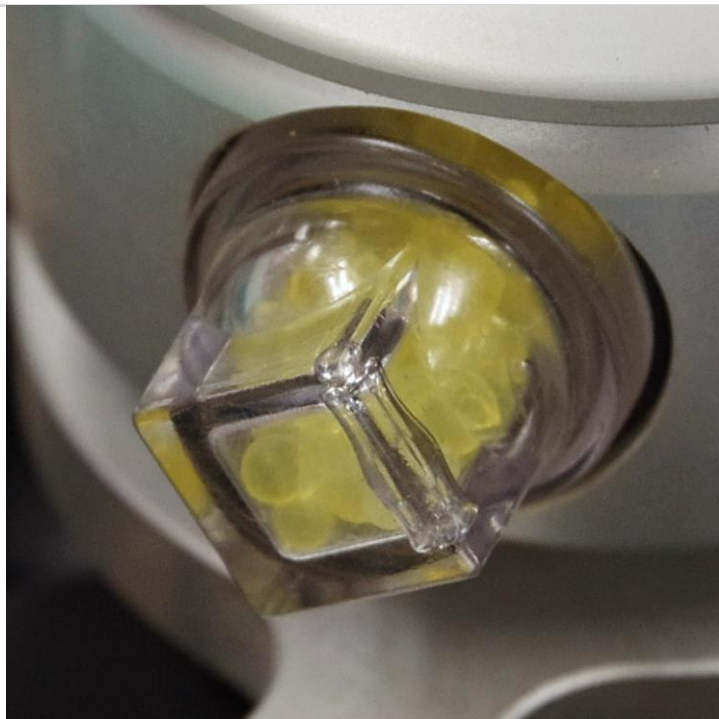
**Figure 8.** Primary Pyranometer with Solar Shield and Ventilator Cover Removed.

- a) Primary Pyranometer
- b) Ventilator Base
- c) Heater Plate
- d) Resistance Heaters
- e) Sensor Cable Connector
- f) Desiccant Canister
- g) Ventilator Fan Air Channels

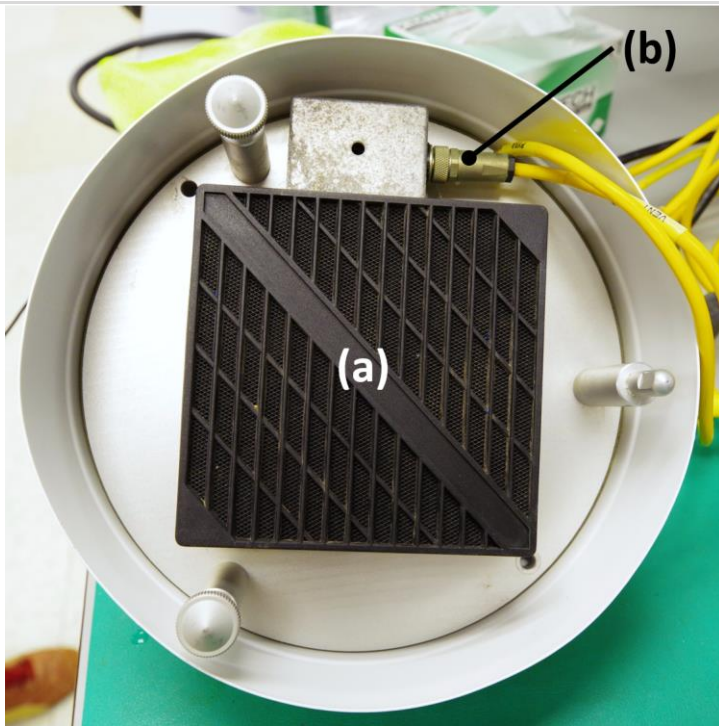


**Figure 9.** Side view of Ventilator Base.

- a) Primary Pyranometer
- b) Ventilator Resistance Heater
- c) Ventilator Fan
- d) Ventilator Heater and Fan Power Cable
- e) Ventilator Gasket

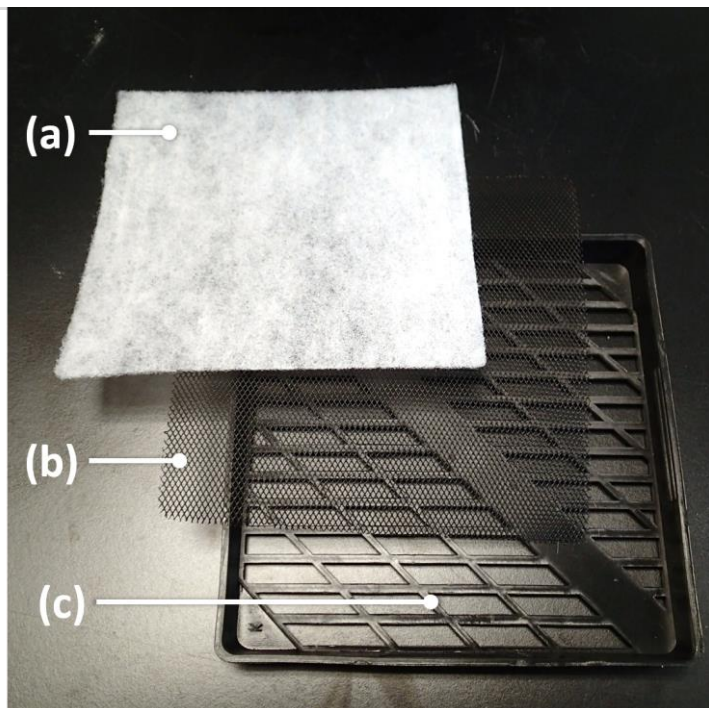


**Figure 10.** Close up of the clear desiccant canister and indicating desiccant attached to the side of the Primary Pyranometer.



**Figure 11.** Underside of the Primary Pyranometer showing the Ventilator Fan. A fan cover with a screen and filter are attached (see **Figure 12**).

- a) Ventilator Fan
- b) Ventilator Fan Power Cable



**Figure 12.** Fan Filter, Filter Screen, and Fan Cover.

- a) Fan Filter
- b) Filter Screen
- c) Fan Cover



#### 4.3.4 Sensor Specific Handling Precautions

The quartz glass surface of the domes of the Primary Pyranometer can be scratched if cleaned with an abrasive cloth or if there is hardened debris (e.g. sand, mineral deposits) on the glass surfaces while being cleaned. The quartz glass domes could also be scratched when removing and/or installing the ventilator cover. The quartz glass domes can also scratch or break if struck by hard objects, and crack or shatter if dropped.

Do not remove the cable directly attached to the Primary Pyranometer (see **Figure 8**) or the Ventilator (see **Figure 9**). The cable connectors are both identical 4-pin connectors and accidentally switching these cables will cause irreparable damage to the Primary Pyranometer.

#### 4.3.5 Operation

The Primary Pyranometer has a unique black surfaced, spectrally non-selective, and highly sensitive thermopile sensor underneath the double quartz glass domes. As solar radiation is absorbed by the black surface of the thermopile sensor, the heat generated flows through a thermal resistance to the sensor housing. The temperature difference is converted to a small voltage that is function of the absorbed solar radiation.

The double quartz glass domes minimize errors by further insulating the thermopile sensor from cooling effects of precipitation and thermal radiation losses to the environment. The ventilator further improves measurement accuracy by lowering thermal offsets and reduces condensation and dust on the dome.

### 4.4 Sunshine Pyranometer

#### 4.4.1 External Components

- Delta-T Sunshine Photometer SPN1
- Merlot G4 Grape 12V

#### 4.4.2 Internal Components

- Desiccant Canister (see Table 3 for part numbers)

#### 4.4.3 Description

The Delta-T Sunshine Photometer SPN1 (hereafter called the Sunshine Pyranometer) measures Global and Diffuse horizontal irradiance. It measures SW radiation between 400 to 2700 nm in  $W m^{-2}$ .

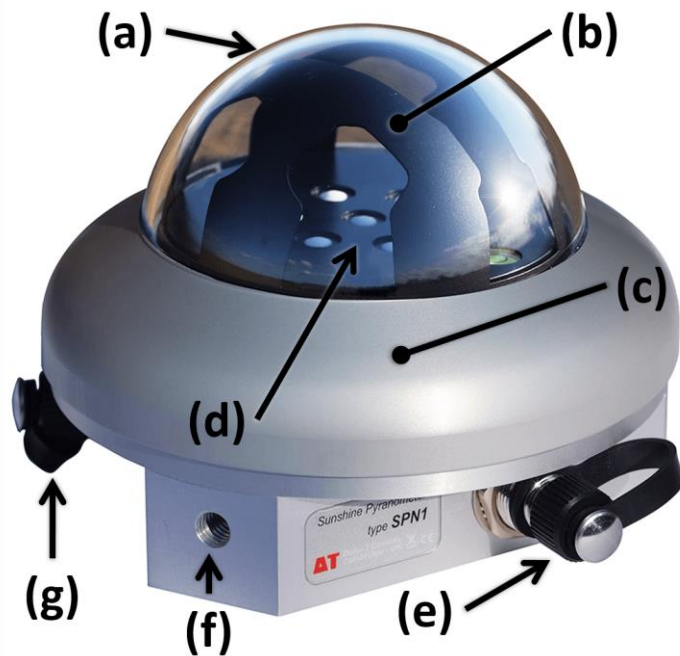
The Sunshine Pyranometer has no moving parts and is comprised of an anodized aluminum body, a borosilicate glass dome, a patterned shadow mask, and a hexagonal shaped array of 7 thermopile radiation sensors with cosine-corrected diffusers (see **Figure 13** through **Figure 17**). It also has a built-in heater designed to disperse dew, frost, rain, and snow. There is an integrated bubble level, red light



emitting diode (LED) indicator, desiccant status indicator, and a user serviceable desiccant canister with a clear humidity indicator window on the side of the unit (see **Figure 19** and **Figure 20**).

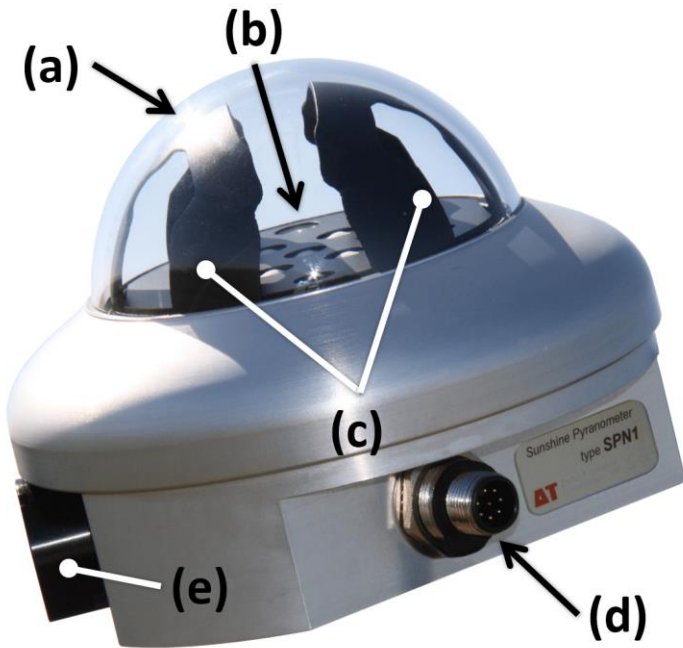
It features two external connectors, a 5-pin RS232 connector for serial communications, and an 8-pin connector for analog signals and power (see **Figure 18**).

During normal operation, the red LED indicator flashes when taking a measurement.



**Figure 13.** Overview photo of the Sunshine Pyranometer

- a) Borosilicate Glass Dome
- b) Shadow Mask
- c) Sensor Body
- d) Thermopile Sensor Array
- e) 5-pin Serial Communications Connector
- f) M8 X 10 mm Threaded Side Mounting Hole
- g) 8-pin Analog Signal and Power Connector

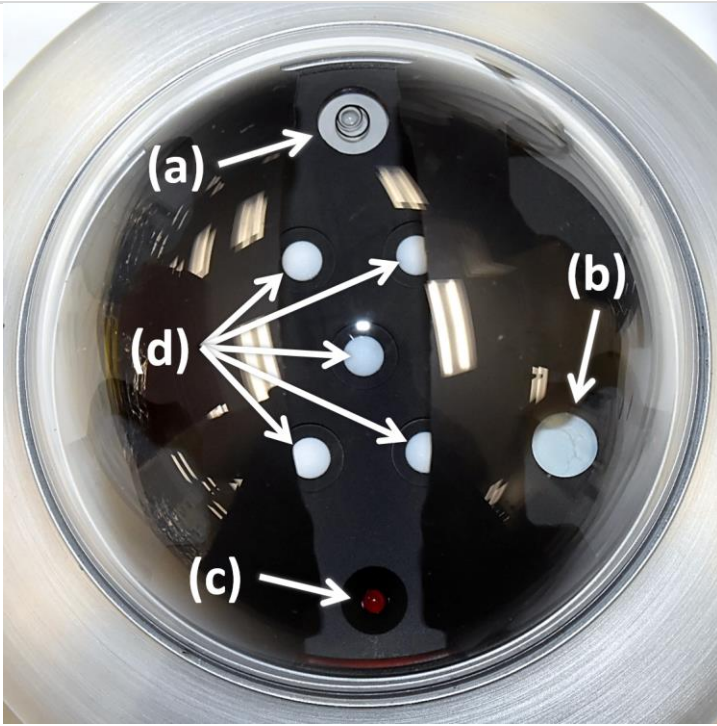


**Figure 14.** Side view of the Sunshine Pyranometer

- a) Borosilicate Glass Dome
- b) Thermopile Sensor Array
- c) Shadow Mask
- d) 8-pin Analog Signal and Power Connector
- e) Desiccant Canister

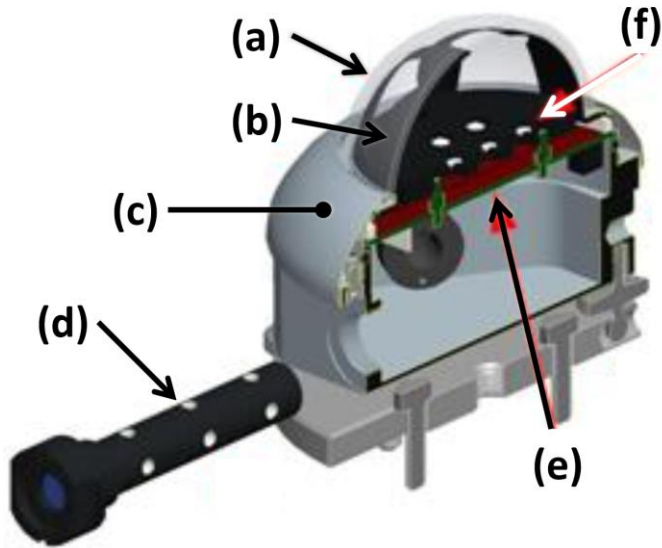
**Figure 15.** Computer generated depiction of the Sunshine Pyranometer's Shadow Mask.





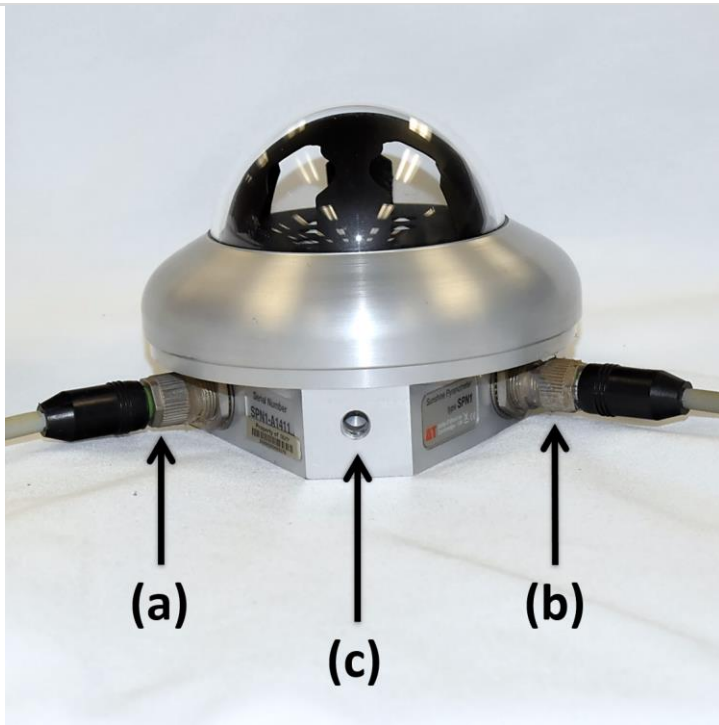
**Figure 16.** Top view of the Sunshine Pyranometer.

- a) Integrated Bubble Level
- b) Desiccant Status Indicator
- c) Red LED Indicator Light
- d) Thermopile Sensor Array



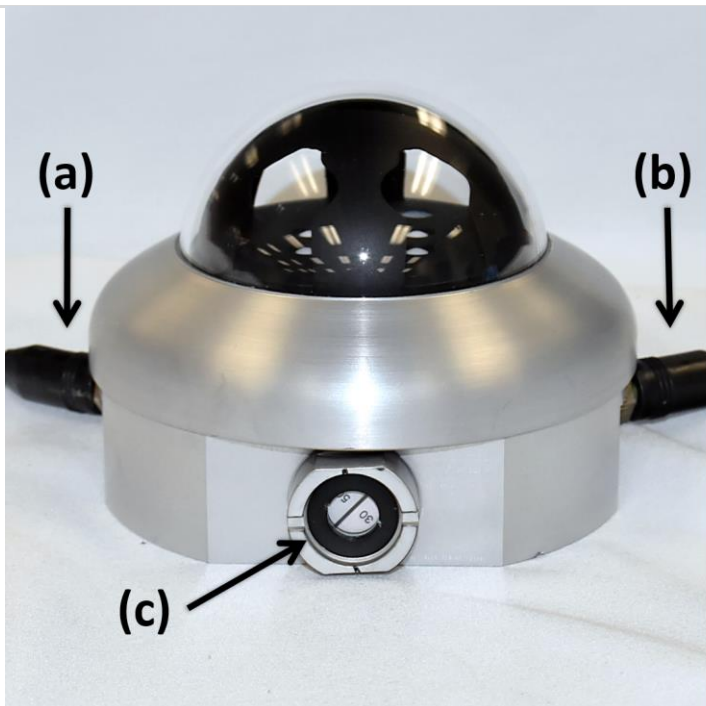
**Figure 17.** Cross-sectional view of the Sunshine Pyranometer.

- a) Borosilicate Glass Dome
- b) Shadow Mask
- c) Sensor Body
- d) Desiccant Canister
- e) Printed Circuit Board (PCB) and Electronics
- f) Thermopile Sensor Array



**Figure 18.** Side view showing locations of the two cable connectors.

- a) 8-pin Analog Signal and Power Connector
- b) 5-pin Serial Communications Connector
- c) M8 X 10 mm Threaded Side Mounting Hole



**Figure 19.** Side view showing location of the desiccant canister humidity indicator window.

- a) 5-pin Serial Communications Connector
- b) 8-pin Analog Signal and Power Connector
- c) Desiccant Canister Humidity Indicator Window





**Figure 20.** Close up of the Humidity Indicator Window on the Desiccant Canister. The numbers indicate 30% and 50% relative humidity (RH).



**Figure 21.** Sunshine Pyranometer mounted atop a TIS Tower.

Location: D08 LENO



Title: NEON Preventive Maintenance Procedure: Radiation Sensors		Date: 04/12/2022
NEON Doc. #: NEON.DOC.004429	Author: R. Zulueta, M. Cavileer, R. Willingham	Revision: C

#### 4.4.4 Sensor Specific Handling Precautions

The borosilicate glass dome of the Sunshine Pyranometer can be scratched if cleaned with an abrasive cloth or if there is hardened debris (e.g. sand, mineral deposits) on the glass surfaces being cleaned. The glass surfaces and domes can also scratch or break if struck by hard objects, and crack or shatter if dropped.

#### 4.4.5 Operation

The Sunshine Pyranometer measures Global and Diffuse horizontal irradiance between 400 to 2700 nm using a hexagonal patterned array of 7 thermopiles sensors and the patterned shadow mask.

The patterned shadow mask has specific areas cut away such that for any sun position:

- At least one detector is always exposed to direct sunlight,
- At least one detector is always completely shaded,
- All detectors receive about equal amounts of diffuse light from the sky.

The Direct, Diffuse, and Global radiation values are derived from these 7 sensor outputs.

### 4.5 Biological Temperature Sensor

#### 4.5.1 External Components

- Apogee SI-111 Infrared Radiometer
  - AI-100 Radiation Shield
- Grape

#### 4.5.2 Description

The Apogee SI-111 Infrared Radiometer (hereafter called the Biological Temperature Sensor) is a non-contact surface temperature measurement device. It measures infrared radiation (between 8-14  $\mu\text{m}$ ) emitted from the target surface and used to determine the surface temperature of the ground. Infrared radiometers are often called infrared thermometers since temperature is usually the desired output.

The Biological Temperature Sensor is a solid-state device and consists of an anodized aluminum, cylindrical body, a thermopile detector, a germanium (Ge) window, and a precision thermistor used as the detector reference temperature. The electronics within the body are fully-potted and therefore completely weather sealed. The germanium window and thermopile are inset within the aperture to protect it from direct solar exposure and to produce the fixed field of view (FOV).

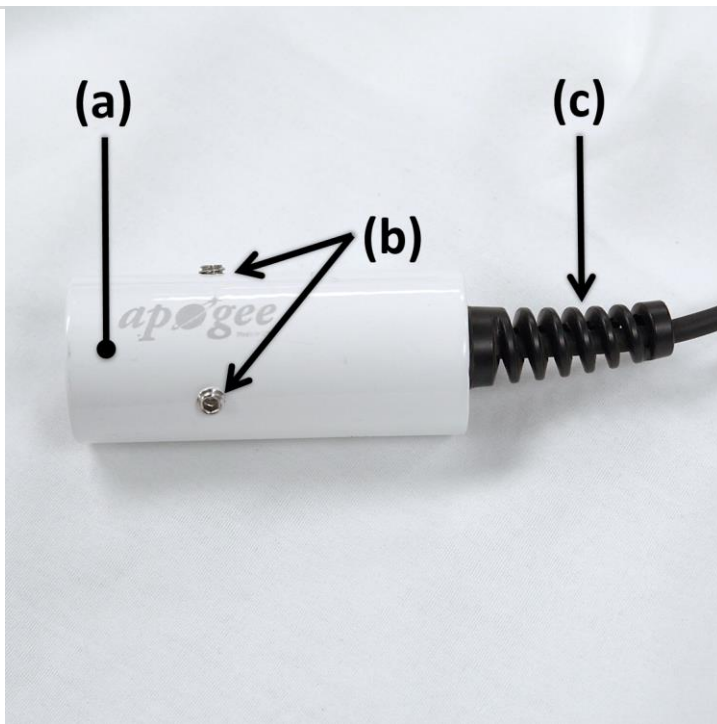
An external solar radiation shield surrounds the entire Biological Temperature Sensor body. The radiation shield is white powder-coated aluminum, spaced  $\frac{1}{4}$  in. (6 mm) from the sensor body providing



enough space for adequate natural aspiration (see **Figure 26** and **Figure 27**). The radiation shield is designed to insulate the Biological Temperature Sensor from rapid temperature fluctuations and direct solar radiation loading. The radiation shield is mounted to the Biological Temperature Sensor via a nylon standoff and set screw towards the base of the sensor (see **Figure 24**), and the ¼ in. (6 mm) space between the sensor and shield is maintained by 3 nylon-tipped set screws (see **Figure 24** and **Figure 26**).

The cables of the Biological Temperature Sensor on Measurement Level 1 (ML1) and the soil plots have an additional stainless steel braiding surrounding the sensor cable (see **Figure 29**) for protection from chewing. The cables for all remaining Measurement Levels ML(s) are thermoplastic elastomer (TPE) jacketed (see **Figure 28**).

The total FOV of the sensor is 44° (ER [12] states FOV as 22° based on the half-angle), and the Biological Temperature Sensor is mounted at a fixed angle of 22° from vertical<sup>1,2</sup> in the soil plots and on the tower booms (see **Figure 30**).

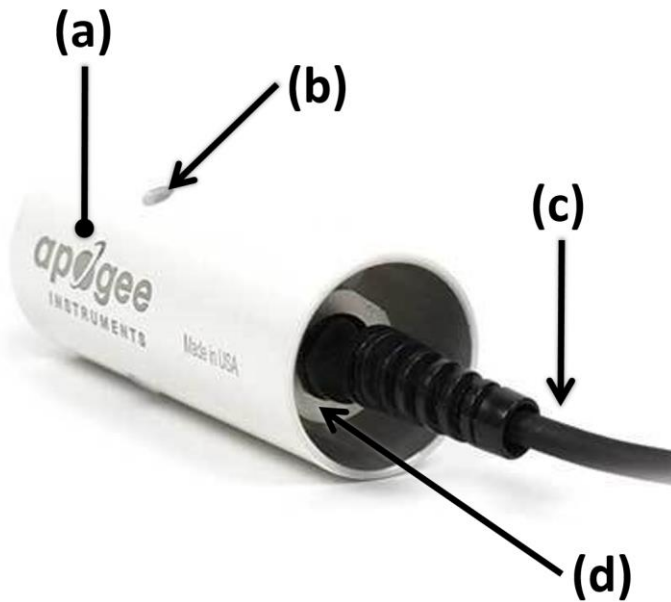


**Figure 22.** Side overview photo of the Biological Temperature Sensor

- a) Solar Radiation Shield
- b) Nylon Tipped Set Screws
- c) Sensor Cable and Strain Relief

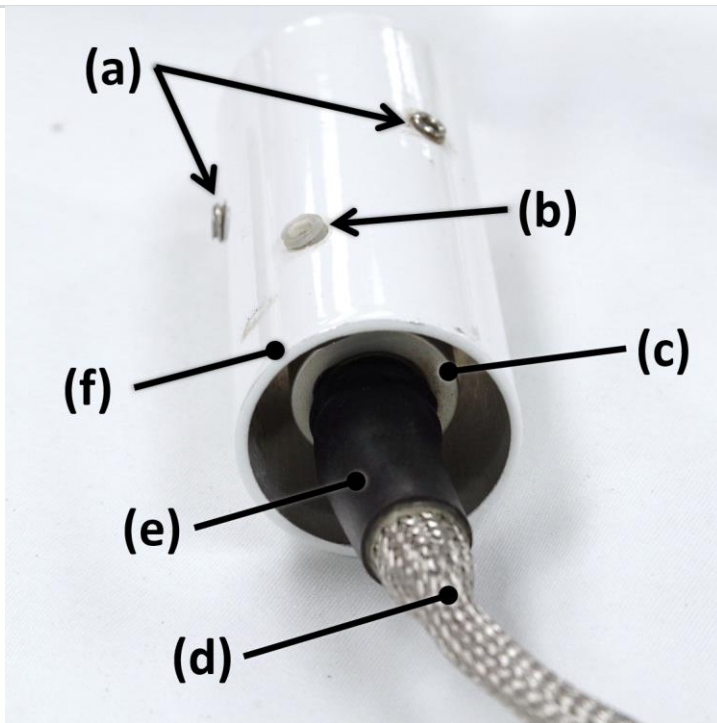
<sup>1</sup> NEON Science Requirement: NEON.TIS.4.1443 (3) – If no plant parts are within 4 meters, the sensor will be mounted facing the ground away from tower structure at an angle of 22° ± 1° from the vertical line.

<sup>2</sup> NEON Science Requirement: NEON.TIS.4.1569 (2) - The sensor will be mounted facing the ground away from mounting structure at an angle of 22° ± 1° from the vertical line.




**Figure 23.** Rear overview photo of a standard Biological Temperature Sensor

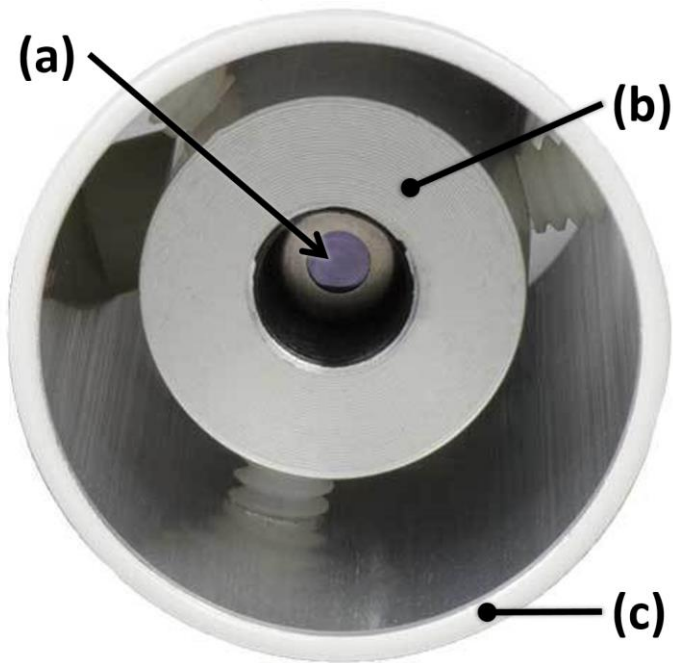
- a) Solar Radiation Shield
- b) Nylon Tipped Set Screws
- c) Sensor Cable and Strain Relief
- d) Biological Temperature Sensor body



**Figure 24.** Rear overview photo of the soil plot and ML1 Biological Temperature Sensor.

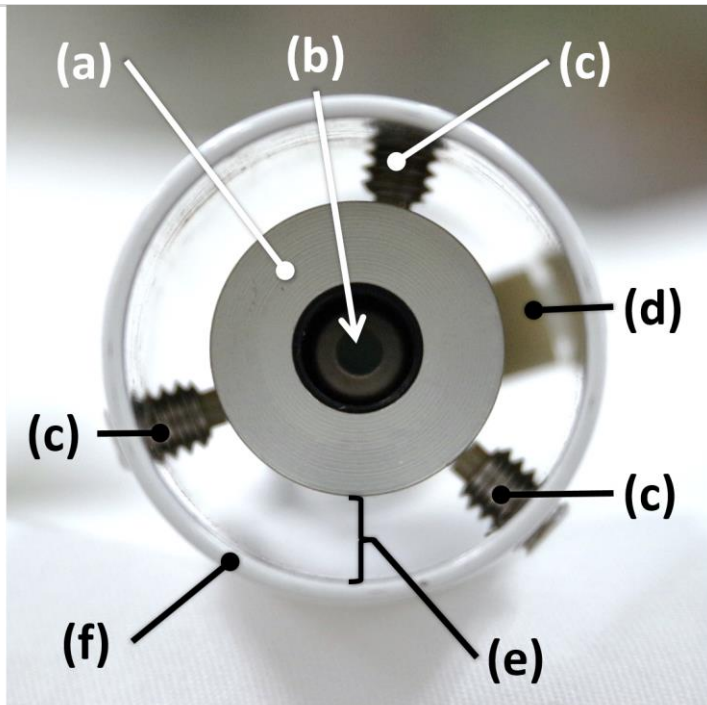
- a) Nylon Tipped Set Screws
- b) Nylon Mounting Screw
- c) Biological Temperature Sensor body
- d) Braided Steel Overwrap
- e) Cable Strain Relief
- f) Solar Radiation Shield

 **NOTE:** The Biological Temperature Sensor mounted in the soil plot and ML1 have a protective braided stainless steel covering over the standard cable (see also **Figure 29**).



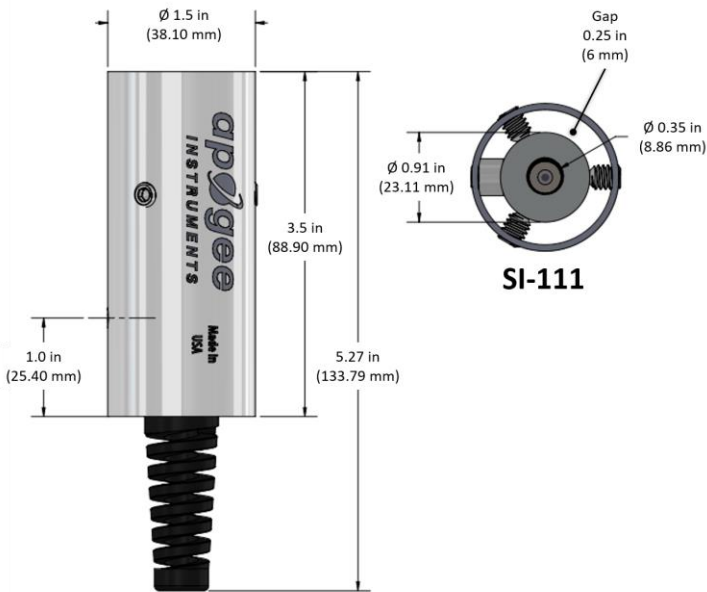
**Figure 25.** Front view of the Biological Temperature Sensor.

- a) Germanium (Ge) Window
- b) Biological Temperature Sensor body
- c) Solar Radiation Shield



**Figure 26.** Head-on view of the Biological Temperature Sensor.

- a) Biological Temperature Sensor body
- b) Germanium (Ge) Window
- c) Nylon Tipped Set Screws
- d) Nylon Mounting Screw
- e) ¼ in. (6 mm) Gap
- f) Solar Radiation Shield




**Figure 27.** Biological Temperature Sensor and radiation shield dimensions.



**Figure 28.** Biological Temperature Sensor and associated TPE jacketed cabling and connectors.



**Figure 29.** Biological Temperature Sensor and associated stainless steel braided cabling and connectors.

 **NOTE:** The Biological Temperature Sensors mounted in the soil plot and ML1 have a protective braided stainless steel covering over the standard cables.



**Figure 30.** Biological Temperature Sensor mounted 22° from vertical.

NEON Location: D14 SRER



**Figure 31.** Biological Temperature Sensor mounted on ML1 along with other sensors.

NEON Location: D14 SRER

#### 4.5.3 Sensor Specific Handling Precautions

The germanium (Ge) window of the Biological Temperature Sensor can be scratched if cleaned with an abrasive cloth or if there is hardened debris (e.g. sand, mineral deposits) on the window surface being cleaned.

Do not remove or separate the solar radiation shield from the Biological Temperature Sensor. The solar radiation shield is attached at NEON HQ with a specialized mounting assembly and procedure for proper alignment and spacing.

#### 4.5.4 Operation

The Biological Temperature Sensor measures infrared (IR) radiation emitted from the ground, vegetation, or water surfaces. The germanium window limits the spectral response of the sensor to the atmospheric window of 8 to 14  $\mu\text{m}$  where there is minimal interference from the atmospheric absorption/emission bands.

The thermopile behind the germanium window absorbs IR radiation between 8 to 14  $\mu\text{m}$  and outputs a small millivolt signal, while the thermistor within the sensor body outputs a millivolt signal proportional to the sensor body temperature. The final output voltage is proportional to the IR radiation balance between the target surface and the sensor body. Essentially, the surface temperature derives from the differences between the outputs of the thermopile and the embedded thermistor.





## 4.6 PAR Quantum Sensor

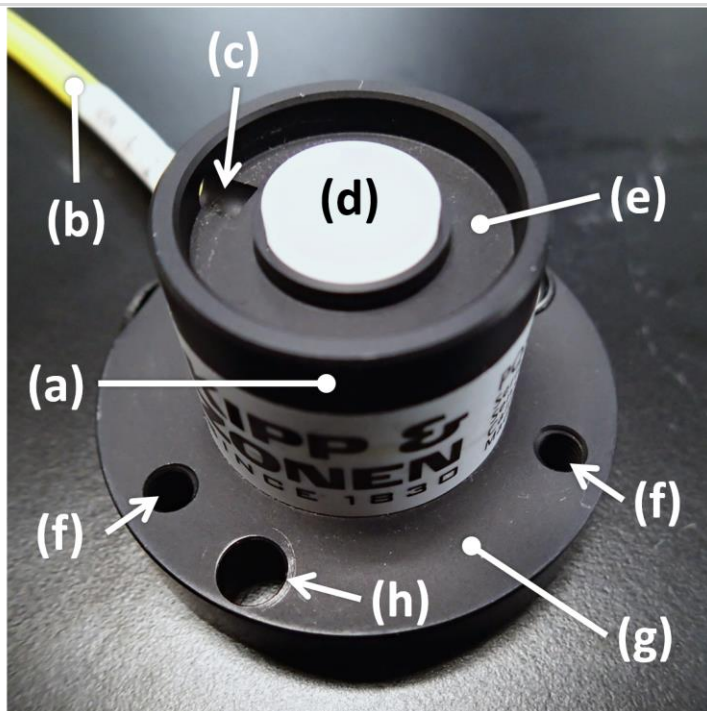
### 4.6.1 External Components

- Kipp & Zonen PQS1 PAR Quantum Sensor
- Grape

### 4.6.2 Description

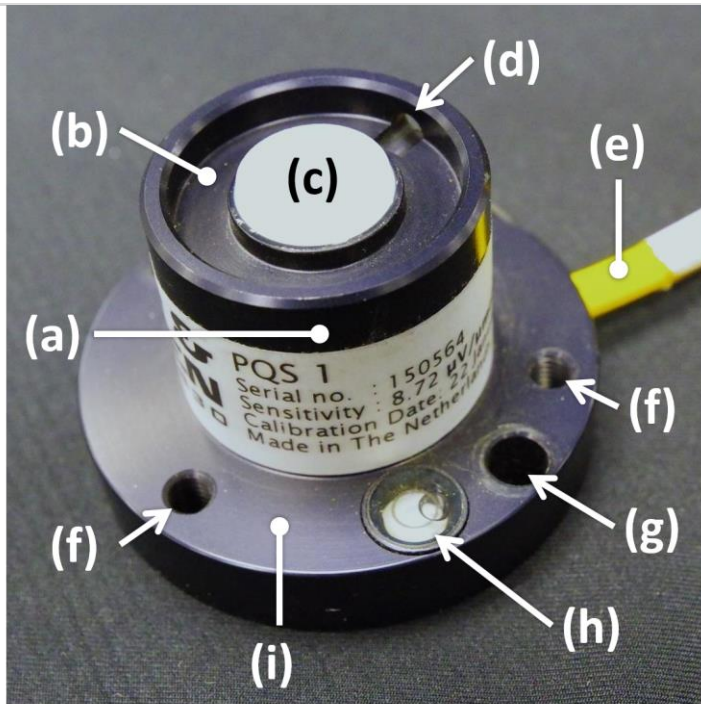
The Kipp & Zonen PQS1 PAR Quantum Sensor (hereafter called the PAR Quantum Sensor) is an instrument designed to measure the amount of incident or reflected light (photons) within the visible spectrum between 400 to 700 nm. Light within this spectral range is used by plants for photosynthesis, and is commonly referred to as Photosynthetically Active Radiation (PAR). The amount of PAR is expressed as Photosynthetic Photon Flux Density (PPFD), with the units of  $\mu\text{mol m}^{-2} \text{s}^{-1}$ .

The PAR Quantum Sensor comprises of a black anodized aluminum body with a circular acrylic light diffuser on top. A water channel and drain hole located at the top of the sensor body drains water to the side of the instrument. The base of the body has a mounting flange with three mounting holes and two additional larger holes to mount two PAR Quantum Sensors back-to-back for simultaneous measurements of incident or reflected PAR (see **Figure 32** through **Figure 34**). There is also an integrated bubble level within the base (see **Figure 33**).



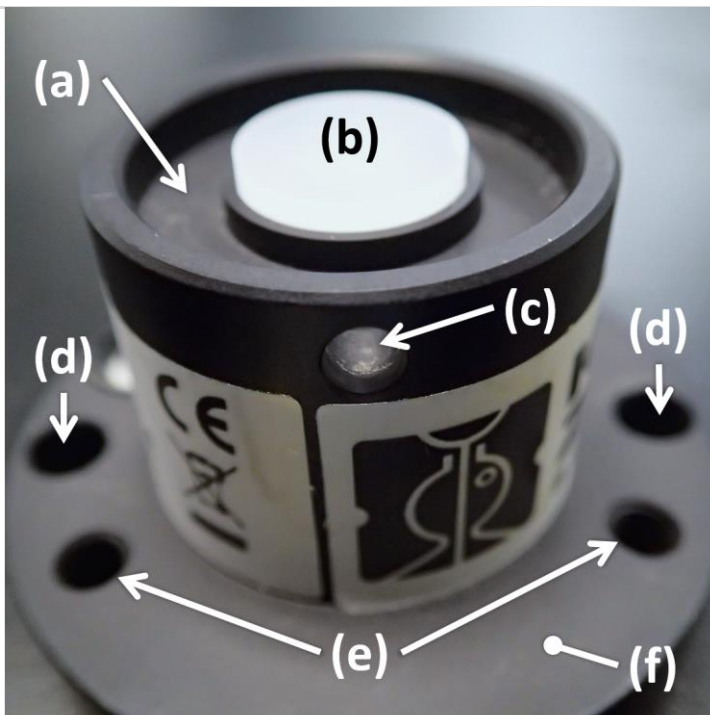
**Figure 32.** Side overview photo of the PAR Quantum Sensor.

- a) Sensor Body
- b) Sensor Cable
- c) Water Drain hole
- d) Light Diffuser
- e) Water Channel
- f) Mounting Holes
- g) Mounting Flange
- h) Back-to-Back Mounting Holes



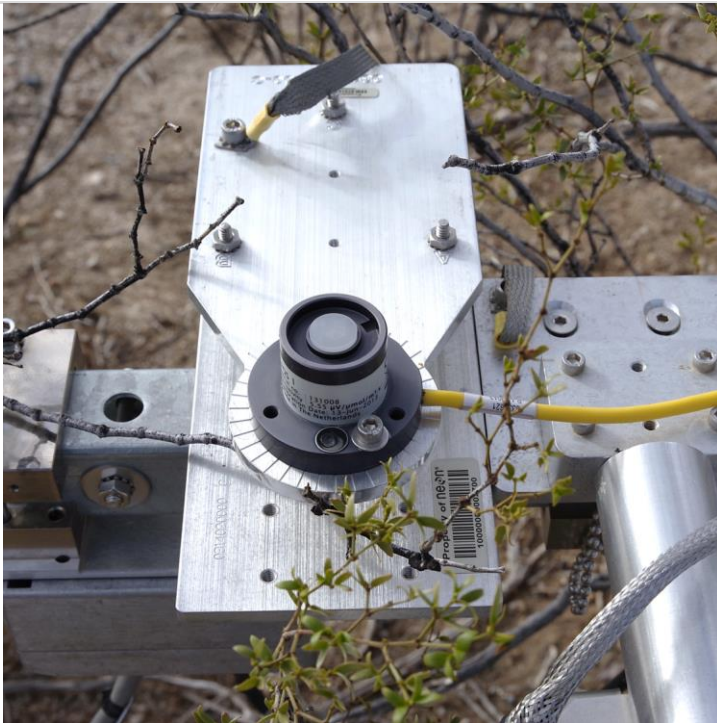
**Figure 33.** Opposite side overview of the PAR Quantum Sensor.

- a) Sensor Body
- b) Water Channel
- c) Light Diffuser
- d) Water Drain Hole
- e) Sensor Cable
- f) Mounting Holes
- g) Back-to-Back Mounting Holes
- h) Integrated Bubble Level
- i) Mounting Flange



**Figure 34.** Side overview showing the water drain hole.

- a) Water Channel
- b) Light Diffuser
- c) Water Drain Hole
- d) Back-to-Back Mounting Holes
- e) Mounting Holes
- f) Mounting Flange



**Figure 35.** PAR Quantum Sensor mounted on ML1 on the TIS Tower.

Location: D14 SRER

#### 4.6.3 Sensor Specific Handling Precautions

The circular light diffuser is acrylic, and scratches and chips easily. Protect the diffuser during transport, maintenance, or installation.

Clean the PAR Quantum Sensor with distilled or deionized (DI) water only. Do NOT use alcohol, organic solvents, abrasives, or strong detergents to clean the diffuser of the PAR Quantum sensor.

#### 4.6.4 Operation

The PQS1 measures incident or reflected light with a photodiode that is located underneath the circular diffuser. The spectral response is between 400 nm and 700 nm and determined by a filter above the photodiode. A resistor shunts the photodiode so a voltage output is measured and recorded.

The light diffuser ensures a FOV of 180° and is cosine corrected (intensity on a horizontal plane is proportional to the cosine angle of the light source).

### 4.7 Quantum Line Sensor

#### 4.7.1 External Components

- LI-COR LI-191 Quantum Line Sensor
- Grape

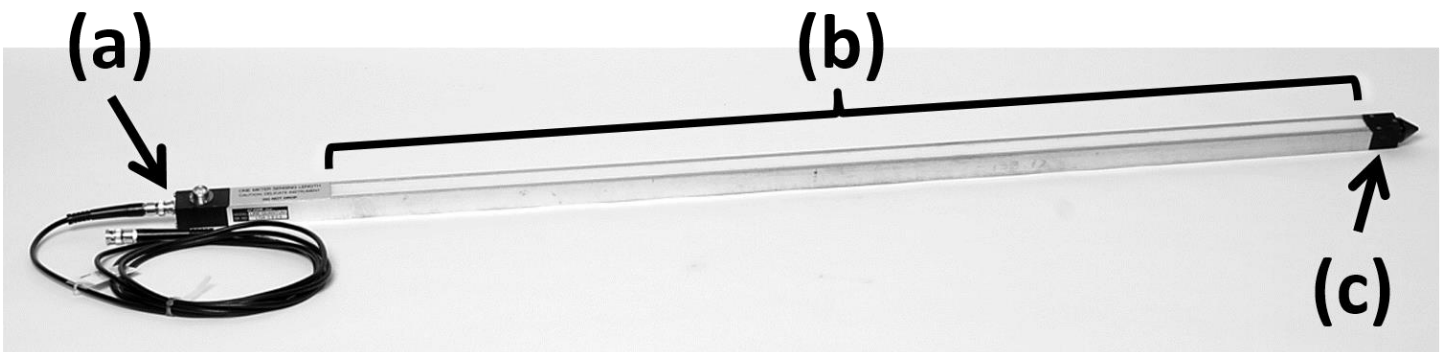


#### 4.7.2 Description

The LI-COR LI-191-01 Line Quantum Sensor (hereafter called the Quantum Line Sensor) is designed to measure PAR underneath a plant canopy where the incoming light is non-uniform. It measures incoming visible light between 400 nm to 700 nm and averages it along its 1-meter sensing length. Plants use light in this spectral range for photosynthesis. The amount of incoming PAR is expressed as PPFD with the units of  $\mu\text{mol m}^{-2} \text{s}^{-1}$ .

The Quantum Line Sensor is a 1.2-meter long light sensor that comprises an all-aluminum body and a 1-meter long by 1.27-cm wide (39.4 in. x 0.50 in.) acrylic diffuser (see **Figure 36**). It has two distinct ends; the connector end which contains the photodiode and the cable connection (see **Figure 37**), and the opposite end which has an anodized aluminum “cone” (see **Figure 38**) used for mounting.

Underneath the acrylic diffuser is a 1-meter long quartz glass rod that directs incoming light from the diffuser to a single, filtered, silicon photovoltaic detector at the connector end of the sensor.



**Figure 36. Overview photo of the Quantum Line Sensor**

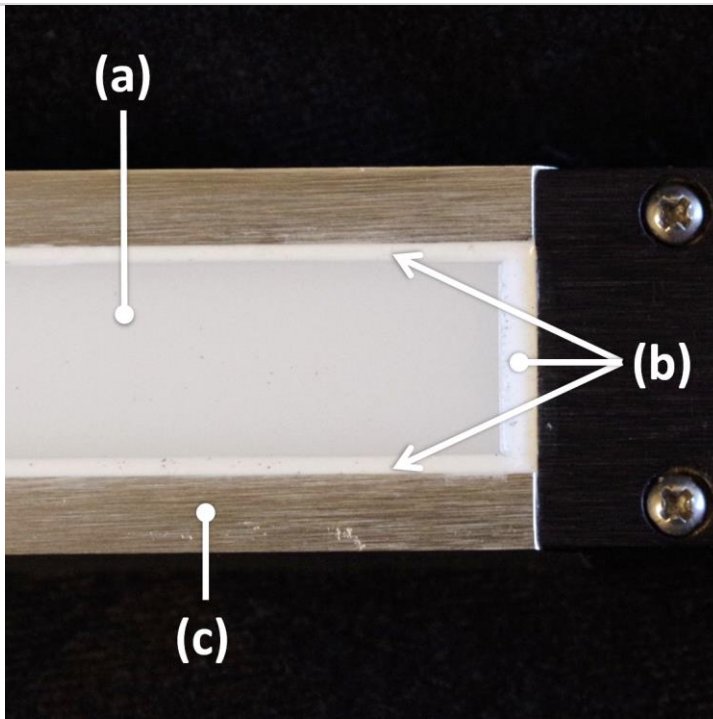
- a) Connector End
- b) Acrylic Diffuser
- c) “Cone” End



**Figure 37.** Close-up of the connector end of the Quantum Line Sensor.



**Figure 38.** Close-up of the "cone" end of the Quantum Line Sensor.



**Figure 39.** Extreme close-up showing the white silicone seal surrounding the diffuser.

- a) Diffuser
- b) White Silicone Seal
- c) Aluminum Sensor Body



**Figure 40.** Quantum Line Sensor installed underneath some vegetation within a soil plot.

Location: D15 ONAQ



**Figure 41.** Quantum Line Sensor installed within a soil plot.

Location: D04 GUAN

#### 4.7.3 Sensor Specific Handling Precautions

The long light diffuser is acrylic, and scratches and chips easily. Protect the diffuser during transport, maintenance, or installation. Use the manufacturer supplied shipping case during transport or shipment. A quartz glass rod spans the length of the Quantum Line Sensor and can be broken if dropped or struck on hard objects or surfaces.

Clean the Quantum Line Sensor with distilled or DI water only. Do NOT use alcohol, organic solvents, abrasives, or strong detergents to clean the diffuser of the Quantum Line sensor.

#### 4.7.4 Operation

The Quantum Line Sensor uses a 1-meter long quartz rod under a diffuser to direct light to a single filtered silicon photodiode. The entire LI-191R diffuser is sensitive to light over its 1-meter length. Since the diffuser is one continuous piece, the LI-191R essentially integrates an infinite number of points over its surface into a single value that represents light from the entire 1-meter length. Optical filters block radiation with wavelengths beyond 700 nm, which is critical for under-canopy measurements, where the ratio of infrared to visible light may be high. The unique design of the LI-191 provides an excellent quantum response that is close to the ideal quantum response.



## 5 INSPECTION AND PREVENTIVE MAINTENANCE

Begin preventive maintenance by first reviewing Section 5.1, Preventative Maintenance Procedural Sequence, to understand the order of the procedure.

### 5.1 Preventative Maintenance Procedural Sequence

1. Review **Table 2** below for preventive maintenance frequency and schedule for each sensor.
2. Inspect and clean sensor glass, dome, or diffuser.
3. Inspect and clean sensor body or ventilator.
4. Inspect and replace desiccant (Primary Pyranometer, Sunshine Pyranometer).
5. Level the sensor.
6. Inspect cables and connectors.
7. Inspect mounting hardware.

### 5.2 Preventive Maintenance Schedule

**Table 2. Preventive Maintenance Frequency and Schedule.**

Maintenance	Bi-weekly	Quarterly	Annual	As Needed	Type
<b>Net Radiometer (NR01)</b>					
Remote Monitoring	X			X	P
Visual Inspection of Sensor	X			X	P
Sensor Dome and Glass Cleaning	X			X	P/R
Sensor Body Cleaning		X		X	P/R
Sensor Leveling	X			X	P
<b>Primary Pyranometer (CMP22)</b>					
Remote Monitoring	X			X	P
Visual Inspection of Sensor	X			X	P
Sensor Dome and Glass Cleaning	X			X	P/R
Sensor Body Cleaning		X		X	P/R
Sensor Leveling	X			X	P
Check Desiccant		X			P
Replace Desiccant				X	P/R
Inspect Desiccant Canister Gasket		X			P
Inspect Ventilator Fan Filter		X			P
Replace Ventilator Fan Filter				X	P/R
Clean Fan Blades				X	R
Replace Fan				X	P
Inspect Solar Shield Gasket		X			P





Replace Solar Shield Gasket				X	R
<b>Sunshine Pyranometer (SMP1)</b>					
Remote Monitoring	X			X	P
Visual Inspection of Sensor	X			X	P
Sensor Dome and Glass Cleaning	X			X	P/R
Sensor Body Cleaning		X		X	P/R
Sensor Leveling	X			X	P
Check Humidity Indicator	X				P
Replace Desiccant Canister				X	R
<b>Biological Temperature Sensor (SI-111)</b>					
Remote Monitoring	X			X	P
Visual Inspection of Sensor	X			X	P
Aperture and Germanium Window Cleaning	X			X	P/R
Sensor Body Cleaning		X		X	P/R
Sensor Leveling (22°)				X	P/R
<b>PAR Quantum Sensor (PQS1)</b>					
Remote Monitoring	X			X	P
Visual Inspection of Sensor	X			X	P
Sensor Dome and Glass Cleaning	X			X	P/R
Sensor Body Cleaning		X		X	P/R
Sensor Leveling	X			X	P
Inspect Water Channel	X				P
Clean Water Channel				X	P/R
Inspect Drain Hole	X				P
Clean Drain Hole				X	P/R
<b>Quantum Line Sensor (LI-191)</b>					
Remote Monitoring	X			X	P
Visual Inspection of Sensor	X			X	P
Sensor Dome and Glass Cleaning	X			X	P/R
Sensor Body Cleaning		X		X	P/R
Sensor Leveling	X			X	P
Inspect Silicone Seals	X				P

*NOTE: The biweekly and annual inspections should be carried out regardless of whether they coincide or not. P = Preventive, R = Repair, X = Indicates preventive maintenance task time interval may increase due to environmental (season/weather) or unforeseen/unanticipated site factors.*



Title: NEON Preventive Maintenance Procedure: Radiation Sensors		Date: 04/12/2022
NEON Doc. #: NEON.DOC.004429	Author: R. Zulueta, M. Cavileer, R. Willingham	Revision: C

### 5.3 Equipment

**Table 3** lists a summary of the preventive maintenance equipment necessary to conduct the procedures herein. Equipment recommendations and applicability may adjust over time as the implementation of NEON sensors and subsystems mature.

**Table 3. Tools, Consumables, and Resource Lists for Preventive Maintenance.**

P/N	Description	Quantity
<b>Tools</b>		
Generic	4mm (M5 Socket Head Screw)	1
Generic	8mm (M5 Nut)	1
Generic	16 mm or 5/8" Open-Ended Wrench/Spanner	1
Generic	24 mm Open-Ended Wrench/Spanner	1
Generic	Adjustable Wrench	1
Generic	Allen Key Set	1
Generic	Soft Bristle Brush (various sizes)	A/R
<b>Consumable items</b>		
Generic	Formula 409, Multi-surface Cleaner (32 oz. spray bottle)	A/R
Generic	Distilled or Deionized water (Squirt/Spray Bottle)	A/R
Generic	Lint-free Cloths or Microfiber Towels	A/R
Generic	Powder-free Nitrile Gloves	A/R
Generic	Trash bag(s)	A/R
Generic	Rags or roll of paper towels	A/R
<a href="#">88693</a>	Danco – Silicone Grease (for rubber gaskets)	A/R
<a href="#">37230</a>	Loctite QuickStix Silver Anti-Seize LB 8060 (for TIS Infrastructure)	1 (A/R)
<a href="#">80337</a>	SAF-T-LOK SAFTEZE Food/Drug Grade Anti-Seize (for AIS Infrastructure)	1 (A/R)
<b>Primary Pyranometer</b>		
2643960	Desiccant – Desiccant Refill Pack (contains 10 sachets)	A/R
2682916	Inlet Filter – Fan Filter Pack (contains 5 filters)	A/R
0015621	Ventilator Cover Retaining Screws for CV2 Ventilator	A/R
<b>Sunshine Pyranometer</b>		
SPN1-SD <sup>3</sup>	Desiccant – Sunshine Pyranometer, SPN1 1 spare desiccant canister (does not include RH indicator plug)	A/R
<b>Resources</b>		
1	Technician	2

<sup>3</sup> Order from US Distributor, Dynamax Inc., Phone: (281) 564-5100



Title: NEON Preventive Maintenance Procedure: Radiation Sensors		Date: 04/12/2022
NEON Doc. #: NEON.DOC.004429	Author: R. Zulueta, M. Cavileer, R. Willingham	Revision: C

#### 5.4 Subsystem Location and Access

**Table 4** lists the radiation sensors and their locations at TIS and AIS sites.

**Table 4. Installation Locations of Radiation Sensors at TIS and AIS Sites.**

Sensor	Manufacturer	Model #	TIS Location(s)	AIS Location(s)
Net Radiometer	Hukseflux	NR01	Tower Top - South West Radiation	Aquatic Met Station
			Soil Plots	AIS Buoy
Primary Pyranometer	Kipp & Zonen	CMP22	Tower Top - South East Radiation	N/A
Sunshine Pyranometer	Delt-T	SPN1	Tower Top - South East Radiation	N/A
Biological Temperature Sensor	Apogee	SI-111	Tower Measurement Levels	N/A
			Soil Plots	
PAR Quantum Sensor	Kipp & Zonen	PQS1	Tower Top - South West Radiation	Aquatic Met Station and S1 and S2 infrastructure
			Tower Measurement Levels - Booms	AIS Buoy
Quantum Line Sensor	LI-COR	LI-191	Soil Plots (Typically in 1, 3, and 5)	N/A

#### 5.5 Maintenance Procedure

Routine maintenance and cleaning of the TIS and AIS Radiation Sensors listed in **Table 5** below can be serviced with a Common Cleaning Procedure (CCP) described in Section 5.5.1.1.

**Table 5. TIS and AIS Radiation Sensors that are serviced with the Common Cleaning Procedure (CCP).**

Sensor	Make	Model
Net Radiometer	Hukseflux	NR01
Primary Pyranometer	Kipp & Zonen	CMP22
Sunshine Pyranometer	Delta-T	SPN1
Biological Temperature	Apogee	SI-111

The two PAR sensors listed in **Table 6** below have acrylic light diffusers covering their sensors. These acrylic diffusers will degrade if any alcohol is used. Only distilled or DI water must be used to clean these sensors. Routine cleaning of the TIS and AIS PAR sensors are serviced with a Modified Common Cleaning Procedure (MCCP) for PAR Sensors described in Section 5.5.1.2.



Title: NEON Preventive Maintenance Procedure: Radiation Sensors		Date: 04/12/2022
NEON Doc. #: NEON.DOC.004429	Author: R. Zulueta, M. Cavileer, R. Willingham	Revision: C

**Table 6. TIS and AIS PAR sensors serviced with the Modified Common Cleaning Procedure (MCCP) for PAR sensors.**

Sensor	Make	Model
PAR Quantum	Kipp & Zonen	PQS1
Quantum Line Sensor	LI-COR	LI-191

**5.5.1 Common Cleaning Procedures**

Preventive maintenance of the TIS and AIS Radiation Sensors listed above in Table 5 can be achieved by simply cleaning the receptor surface of the sensor (i.e. glass or quartz glass dome, light diffuser, or lens). Routine cleaning can be achieved with a lint-free cloth or microfiber towel and distilled or deionized (DI) water, followed by a rinse with 95% ethanol (PAR sensors use only distilled or DI water), dried with a lint-free cloth or microfiber towel, and a final spray of compressed air. The combination of these help ensure a clean and residue-free sensor surface.

Routine cleaning of radiation sensors is very straightforward, however care must be taken not to scratch the sensor’s receptor surface, and once cleaned that no residue or streaks are left behind. Always rinse the sensor surface with distilled or DI water to remove any loose dust, dirt, or residue that may inadvertently scratch the sensor surface. It should be emphasized that “dry” wiping of a radiation sensor’s receiving surface should be avoided. Use only gentle pressure when cleaning the surfaces of the radiation sensors.


The liquid should be allowed to do the cleaning, not mechanical force.

**5.5.1.1 Common Cleaning Procedure (CCP)**

1. Place a small container or catch basin underneath the sensor to catch excess dirt, water, or ethanol runoff.
2. Spray distilled or DI water on the sensor’s receiving surface (i.e. glass or crystal dome, light diffuser, or lens) and allow water to run off. This should remove most loose dust, dirt, or residue.
3. Spray some distilled or deionized water on one corner of a clean lint-free cloth.
4. Wipe the sensor’s receiving surface with the wet part of the cloth.
5. Wipe dry the sensor’s receiving surface with the dry portion of the cloth.
6. Dispose of the used lint-free cloth.
7. Spray a small amount of 95% ethanol on a corner of a new and clean lint-free cloth.
8. Wipe the sensor’s receiving surface with the wet part of the cloth.
9. Wipe dry the sensor’s receiving surface with the dry portion of the cloth.
10. Dispose of the used lint-free cloth or microfiber towel.
11. Use a new and clean lint-free cloth or microfiber towel to dry the sensor’s receptor surface until completely dry and ensure there are no streaks or smudges on the sensor’s receptor surface.
12. If necessary, follow up steps 2 through 8 until sensor surface is clear of streaks or smudges.



13. Finish with several short “blasts” of compressed air from 4” to 6” away to remove any remaining lint or dust.

 **NOTE:** If there is an aperture and inset lens (e.g. Biological Temperature) that cannot be sufficiently accessed with a lint-free cloth, a cotton swab may be used in place of the lint-free cloth.

#### 5.5.1.2 Modified Common Cleaning Procedure (MCCP) for PAR Sensors

1. Place a small container or catch basin underneath the sensor to catch excess dirt, water, or ethanol runoff.
2. Spray distilled or DI water on the sensor’s receiving surface (i.e. glass or crystal dome, light diffuser, or lens) and allow water to run off. This should remove most loose dust, dirt, or residue.
3. Spray some distilled or deionized water on one corner of a clean lint-free cloth or microfiber towel.
4. Wipe the sensor’s receiving surface with the wet part of the cloth.
5. Wipe dry the sensor’s receiving surface with the dry portion of the cloth.
6. Repeat Steps 2 through 5.
7. Dispose of the used lint-free cloth or microfiber towel.
8. Use a new and clean lint-free cloth or microfiber towel to dry the sensor’s receptor surface until completely dry and ensure there are no streaks or smudges on the sensor’s receptor surface.
9. If necessary, follow up steps 2 through 8 until sensor surface is clear of streaks or smudges.
10. Finish with several short “blasts” of compressed air from 4” to 6” away to remove any remaining lint or dust.

#### 5.5.2 Specific Conditions Cleaning Procedures (SCCP)


##### 5.5.2.1 SCCC - Dew

- Follow the Common Cleaning Procedure (CCP) or Modified Common Cleaning Procedure (MCCP) for PAR Sensors


##### 5.5.2.2 SCCC - Frost

- Temperature **above** freezing.
  1. Follow the Common Cleaning Procedure (CCP) or Modified Common Cleaning Procedure (MCCP) for PAR Sensors.
- Temperature **below** freezing.
  1. Follow the Common Cleaning Procedure (CCP) for radiation sensor listed in **Table 5**, but use 95% ethanol for all procedural steps.
  2. PAR Sensors – Follow the Modified Common Cleaning Procedure (MCCP) for PAR Sensors, but use hot water for all procedural steps.




 NOTE: Do NOT use alcohol, organic solvents, abrasives, or strong detergents to clean the diffuser of the PAR Quantum Sensor or the Quantum Line Sensor.

### 5.5.2.3 SCCP - Snow


 NOTE: During times when the ground snow depth is higher than the sensor itself, no preventative maintenance should be performed on this sensor. If the sensor is covered in snow but above the ground snow depth, sensor maintenance should be performed as described.

1. First attempt to remove excess snow with minimal touching the sensor's receiving surface. This should be done with a soft bristle brush in a back and forth sweeping motion.
2. Once excess snow is removed, follow procedure Section 5.5.2.2, SCCP - Frost.

 NOTE: Do NOT use alcohol, organic solvents, abrasives, or strong detergents to clean the diffuser of the PAR Quantum Sensor or the Quantum Line Sensor.

### 5.5.2.4 SCCP – Ice

1. Radiation Sensors listed in **Table 5** above.
  1. Place small container or catch basin underneath the sensor.
  2. Spray the sensor's surface with 95% ethanol, allowing the alcohol to melt the ice buildup.
  3. Repeat until ice is removed. The ethanol should be allowed to do the melting, not mechanical force
  4. Once the ice is removed, follow the procedure in Section 5.5.2.2, SCCP - Frost.
2. **PAR Sensors** listed in **Table 6** above
  1. Place small container or catch basin underneath the sensor.
  2. Spray the sensor's surface with hot distilled or DI water, allowing the hot water to melt the ice buildup.
  3. Repeat until ice is removed. The hot water should be allowed to do the melting, not mechanical force.
  4. Once the ice is removed, follow the procedure in Section 5.5.2.2, SCCP - Frost.

 NOTE: Do NOT use alcohol, organic solvents, abrasives, or strong detergents to clean the diffuser of the PAR Quantum Sensor or the Quantum Line Sensor.

### 5.5.2.5 SCCP - Salt Deposits

Salt deposits can accumulate on the sensor's receiving surface. These deposits can be seen as a thin white film or white spots or accumulations. The Common Cleaning Procedure (CCP) and the Modified



Common Cleaning Procedure (MCCP) for PAR Sensors should remove light salt deposits, though heavier buildup may require the use of a solvent (e.g. 0.1 M acetic acid) to dissolve the deposits.

1. Follow the Common Cleaning Procedure (CCP) or the Modified Common Cleaning Procedure (MCCP) for PAR Sensors.
2. If the salt deposits remain, or are caked-on, use of 0.1 M acetic acid may be required.
  - a. See instrument specific procedure for heavy or caked-on salt deposits.

#### 5.5.2.6 SCCP - Insect Nests

Spiders or other insects may form nests on or around the sensor, and may block or obscure the radiation sensor.

1. Use a cotton swab to remove as much of the insect nest or spider webbing as possible, without touching the radiation sensor's surface.
2. Follow the Common Cleaning Procedure (CCP) or the Modified Common Cleaning Procedure (MCCP) for PAR Sensors.

#### 5.5.2.7 SCCP - Bird Dropping and Other Droppings

It never fails, but any upward facing radiation sensor seems to be a perpetual target for birds and their droppings. If birds are in the area, you can almost be assured that they have taken multiple "passes" at the radiation sensor attempting to hit the "bullseye" and ruin your data and your day. This may be anthropomorphizing it a bit, but they are definitely "target practicing"!

1. Place small container or catch basin underneath the sensor to catch any excess liquid runoff.
2. Spray the sensor's surface with distilled or deionized water allowing it to "soak in" and loosen the debris.
3. Continue spraying with distilled or DI water, attempting to loosen and remove the debris with the water.
4. If droppings remain, use a cotton swab to aid in loosening and removing the debris. Use only gentle pressure and continue spraying with water.
  - o The liquid should be allowed to do the cleaning, not mechanical force.
5. Once the debris is removed, follow the Common Cleaning Procedure (CCP) or the Modified Common Cleaning Procedure (MCCP) for PAR Sensors.

#### 5.5.2.8 SCCP – Wildlife

The radiation sensors will operate normally under this condition. However, the tower top and ends of the booms where the sensor is located may attract wildlife, particularly birds and lizards, and sometimes even snakes.



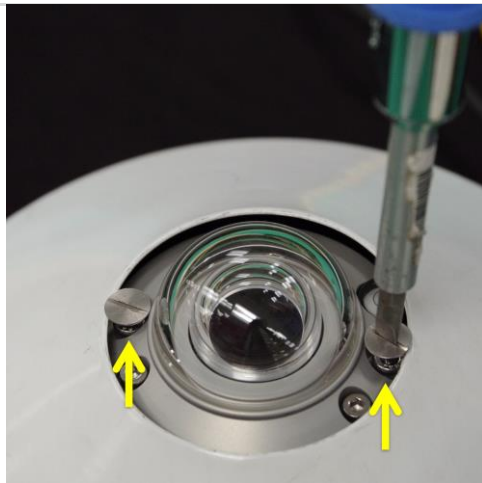
1. Use common sense on whether it would be safe, easy, and/or appropriate to try to ward off any wildlife off the tower top or from the booms.
2. Consult with local agencies and authorities regarding nesting birds.

### 5.5.3 Sensor Specific Maintenance Procedures

#### 5.5.3.1 Primary Pyranometer

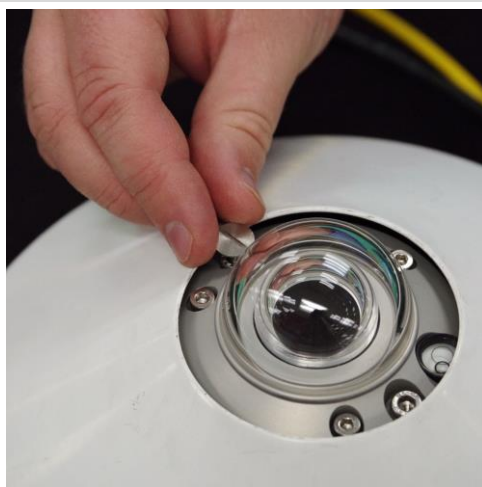
##### 5.5.3.1.1 Removing the Solar Shield

The Solar Shield must be removed in order to perform preventive maintenance on the internal desiccant.



**Step 1.** Using a flat-head screw driver, loosen the two top retaining screws.

***Note:** These retaining screws are lost easily, definitely have spares (see Table 3 for part numbers).*



**Step 2.** Once the retaining screw is loose, use your fingers to remove them the rest of the way.





**Step 3.** Lift the ventilator cover straight up to remove.

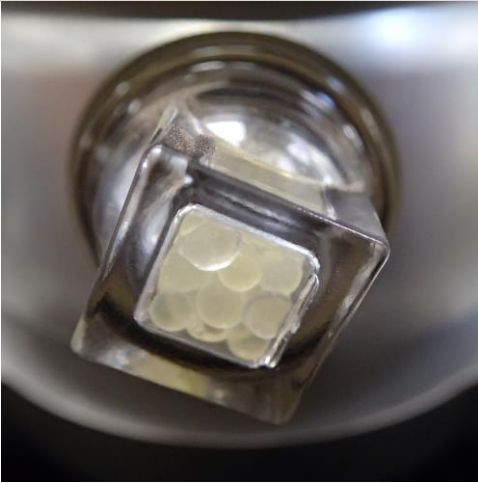
#### 5.5.3.1.2 Desiccant Inspection

There is an indicating desiccant within the body of the Primary Pyranometer which can be seen via a transparent window on the side of the sensor body (see **Figure 5**). Inspect the color of the desiccant and record it during routine preventive maintenance as a color change in the desiccant may indicate replacement is needed.

The color of the desiccant is typically **orange** when dry and **clear** when wet. It should be replaced when 50% of the desiccant (visible in the window) is clear.

1. Remove the solar shield from the sensor.
2. Inspect and record the color and clarity of the desiccant
  - a. If replacement is required see Section 5.5.3.1.3 below)
  - b. If not required proceed to next step.
3. Replace solar shield.

**Step 1.** Remove the ventilator cover. Follow procedure in Section 5.5.3.1.1



**Step 2.** Inspect the color of the desiccant.

The color of the desiccant is typically **orange** when dry and **clear** when wet. Replace when 50% of the desiccant is clear.

Compare picture to the left against **Figure 10**.

### 5.5.3.1.3 Desiccant Replacement



**Step 1.** Using a 16 mm or 5/8" wrench, loosen the desiccant canister.



**Step 2.** Once the desiccant canister is loose, use your fingers to remove it the rest of the way.



**Step 3.** Carefully remove the cap of the desiccant canister by pulling straight up on it.



**Step 4.** Using a fresh desiccant sachet (see **Table 3**), replace the used desiccant.



**Step 5.** Once refilled, replace the cap.



**Step 6.** Inspect the rubber gasket and apply a very thin coating of silicone grease.



**Step 7.** Replace the desiccant canister into the sensor body. Do not over tighten.



### 5.5.3.2 Sunshine Pyranometer

#### 5.5.3.2.1 Desiccant Inspection

There is a humidity indicator visible through the top dome that indicates the humidity of the air within the Sunshine Pyranometer dome (see **Figure 16**). There is also an indicating desiccant canister with a transparent window within the body of the Sunshine Pyranometer (see **Figure 17** and **Figure 19**). The transparent window on the desiccant canister has a split level humidity indicator signifying either 30% or 50% relative humidity (see **Figure 20**).

Either of these can be used to determine whether the desiccant cartridge within the body of the Sunshine Pyranometer needs replacing. The color of the top indicator and the state of the side indicator should be recorded during routine preventive maintenance as the color change in the desiccant may indicate that it's time to replace the desiccant.

The color of the desiccant is typically **blue** when dry and **pink/red** when wet. The desiccant cartridge should be replaced when the top indicator is pink, or the side split-level indicator reads 50% (the 50% indicator is pink).

#### 5.5.3.2.2 Desiccant Replacement



**Step 1.** Using a 24 mm wrench or adjustable wrench, loosen the desiccant canister.




**Step 2.** Once the desiccant canister is loose, use your fingers to remove it the rest of the way.



**Step 3.** Separate the canister from the Humidity Indicator Window by holding the cap and unscrewing the canister from the cap.



**Step 4.** Replace the desiccant canister with a new one and attach to the Humidity Indicator Window.

 *Note: Save the old desiccant canister as it can be regenerated. See Section 5.5.3.2.3 for regenerating the desiccant canister.*



**Step 5.** Inspect the rubber gasket and apply a very thin coating of silicone grease.

***Note:** The gasket is difficult to see but it is located within the Desiccant Indicator Window cap.*



**Step 6.** Replace the desiccant canister into the sensor body.



**Step 7.** Using a 24 mm wrench or adjustable wrench, tighten the desiccant canister. Do not overtighten.



### 5.5.3.2.3 Desiccant Regeneration

The desiccant canister can be regenerated by heating in a ventilated drying oven. Do not use a microwave.

1. Set drying oven temperature to 100°C (212° F).
2. Place entire desiccant canister into the oven for 4 hours.
3. Allow to cool.
4. Store regenerated desiccant canister in a zipper seal bag until needed.

### 5.5.3.3 Biological Temperature Sensor

#### 5.5.3.3.1 Solar Radiation Shield

*Insect nests are an issue in the Solar Radiation Shield because they may block airflow and elevate temperature readings (see ER [16]). This issue is likely to occur across all sites and increase in occurrence when winter dissipates and spring approaches, through late fall.*

*Compare measurement readings from this sensor with others on TIS Tower or nearby AIS sites to see if there are significant variances in the readings. The variance displays a possible symptom of an insect or arachnid finding shelter in the Solar Radiation Shield.*

*Check instruments closer to shrubbery and bushes more frequently remotely, since specific terrain may influence the frequency of arachnids finding a home in the sensor. The higher the sensor is from low-lying shrub, the more likely wasps, bird droppings and ice may accumulate and cause variances in the sensor readings.*

*If insects, such as wasps, are making it difficult to access the instruments and conduct day-to-day operations, use a wasp trap per [NEON-8638](#) or a Bee suit per [NEON-4175](#), and fill gaps with a mesh grate, where applicable. A generic wasp spray is OK for use on Comm/Power Infrastructure onshore at AIS sites per [NOEN-2994](#). Consult with the NEON Safety Office for additional countermeasures if normal remediation does not resolve or reduce the issue.*

#### 5.5.3.3.2 Aperture

The aperture of the Biological Temperature Sensor is the opening in the sensor body that provides the specified FOV. The germanium window is inset in the aperture (see **Figure 25**) and provides some protection to the germanium window. Partial or complete blockage of the aperture could happen in three ways:

1. Spiders (or other insects) can make a nest at the entrance or within the aperture.
  - Using a cotton swab, remove the spider nest.
  - Proceed with the Common Cleaning Procedure (CCP).






- Some insect repellent can be used around the entrance of the aperture, but do not apply the repellent to the window itself. If used, wipe on the repellent, do not spray.
- 2. Calcium deposits can accumulate on the window and within the aperture if irrigation water sprays up on the sensor. These deposits typically leave a thin white film on the surface.
  - Use a cotton swab and 0.1 M acetic acid to remove the mineral deposits. Allow the acetic acid to dissolve the deposits and repeat as necessary.
  - Proceed with the Common Cleaning Procedure (CCP).
- 3. In windy environments, dust and dirt can be deposited in the aperture.
  - Proceed with the Common Cleaning Procedure (CCP).

Clean the inner threads of the aperture using a cotton swab and distilled or DI water.

#### 5.5.3.4 PAR Quantum Sensor

##### 5.5.3.4.1 Diffuser Edge

 NOTE: Do NOT use alcohol, organic solvents, abrasives, or strong detergents to clean the diffuser of the PAR Quantum Sensor or the Quantum Line Sensor.

There is an “edge” to the sensor’s light diffuser (see **Figure 42**) that requires routine cleaning to maintain proper cosine corrections. Clean the diffuser edge when cleaning the top of the diffuser.

1. Use a cotton swab and distilled or DI water to clean the edge of the light diffuser.
2. Proceed with the Modified Common Cleaning Procedure (MCCP) for PAR Sensors.



**Figure 42.** The vertical edge of the PAR Quantum Sensor light diffuser.




#### 5.5.3.4.2 Water Channel and Drain Hole

A water channel and water drain hole at the top of this sensor (see **Figure 34**) must be clear to ensure proper water drainage.

Just before performing the routine preventive maintenance via the Modified Common Cleaning Procedure (CCP):

1. Insert a toothpick into the drain hole to clear any dirt or debris.
2. Use a cotton swab to clean the water channel of any dirt or debris.
3. Proceed with the Modified Common Cleaning Procedure (MCCP) for PAR Sensors.

#### 5.5.3.5 Quantum Line Sensor

 NOTE: Do NOT use alcohol, organic solvents, abrasives, or strong detergents to clean the diffuser of the PAR Quantum Sensor or the Quantum Line Sensor.

Upon routine maintenance of the Quantum Line Sensor, visually inspect the silicone gaskets along the entire length of the diffuser (see **Figure 39**). Damage to the gasket will allow water to enter the device and may damage the photodiode. Report any damage to the gasket via the NEON project issue reporting system (e.g. JIRA, ServiceNow).

#### 5.5.4 Leveling

The radiation sensors should be kept level with the horizontal plane for the most accurate measurements, the exception is the Biological Temperature Sensor which should be kept at 22° from the vertical plane. Leveling of each sensor or sensor subsystem is described in Section 6 - Removal and Replacement (Subsystem Only). Cables and Connectors

The cables and connectors should be intact without any breaks or cracks, and the cables securely fastened to the support arm or other infrastructure.

1. Visually inspect cables and connectors for damage from the elements (sun, wind, and water), animals, and insects.
  - a. Replace missing, broken, or brittle cable ties.

#### 5.5.5 Mounting Nuts and Bolts

The mounting nuts and bolts should be clean of corrosion that would prevent easy removal of the radiation shield or component sections.

1. Visually inspect nuts and bolts.
  - a. If light corrosion is present
    - i. Clean with a small wire brush.



<i>Title:</i> NEON Preventive Maintenance Procedure: Radiation Sensors		<i>Date:</i> 04/12/2022
<i>NEON Doc. #:</i> NEON.DOC.004429	<i>Author:</i> R. Zulueta, M. Cavileer, R. Willingham	<i>Revision:</i> C

- b. If heavy corrosion is present,
  - i. Clean with a small wire brush
  - ii. Remove the nut or bolt.
  - iii. Apply the appropriate anti-seize compound (see Table 3) to the threads, and replace the nut or bolt.



Title: NEON Preventive Maintenance Procedure: Radiation Sensors		Date: 04/12/2022
NEON Doc. #: NEON.DOC.004429	Author: R. Zulueta, M. Cavileer, R. Willingham	Revision: C

## 6 REMOVAL AND REPLACEMENT (SUBSYSTEM ONLY)

### 6.1 Equipment

**Table 7** contains a list of equipment to conduct sensor refresh at TIS and AIS sites for specific instrumentation and/or subsystem components that require calibrations and validations. This also includes unique equipment necessary for removal and replacement procedures. Equipment recommendations and applicability may adjust over time as the implementation of NEON sensors and subsystems mature.

**Table 7. Removal and Replacement Equipment List.**

P/N	MX/NEON	Description	Quantity
<b>Tools</b>			
4620	MX103120	3M Antistatic Wristband (ESD Requirement)	1
NEON, IT		NEON Laptop (for AIS only to connect to Aquatics Portal)	1
GENERIC		Ethernet Cable (for AIS only to connect to Aquatics Portal)	1
GENERIC		3/16" & 5/32" Allen Wrench (to remove Grapes Mounts and Sensors)	1
GENERIC		Speed Wrenches (to remove sensor mounting hardware)	1
GENERIC		1" to 3/4" pipe reducer (for NR01 mount, optional)	1
GENERIC		Digital Level (to level radiation sensors post-installation)	1
GENERIC		Hex Wrench Set (to remove/reinstall sensors)	1
GENERIC		11-in-1 (to remove/reinstall sensors)	1
GENERIC		Phillips-Head Screwdriver (to access Power Box Breakers)	1
GENERIC		Flathead Screwdriver (to access Power Box Breakers)	1
Safety		Site-Specific PPE for TIS and AIS sites	A/R
Safety		LOTO Equipment (required over 50 Volts)	A/R
GENERIC		Flush cutters/Scissors (to cut zip ties/remove zip ties)	1
GENERIC		Wood plank, rubber mat, or similar (~60x 40 cm) for standing on in soil plot	1
GENERIC		<a href="#">Telescoping/Inspection Mirror</a> (to view bubble level on sensors)	1
GENERIC	MX106639	Sturdy Container and/or Backpack (to transport sensors)	1
NEON ENG	CA02630010	Assembly, Inclinator, 6ft non-rotating (Inclinometer 0750 Series 12-8 connector to USB)	1
NEON ENG	CD06121840	Assembly, Kit, Cable Harness, 2 PoE 40 ft., 1 Inclinometer, Tower Top Boom	1
NEON ENG	CD06181240	Assembly, Kit, Cable Harness, 2 PoE 40 ft., 2 Inclinometer, Tower Top Boom	1
<a href="#">202309380</a>		2-3/4 in. Stainless-Steel Clamp Hose Clamp (Bump Stop for Buoy)	1-2
GENERIC		Torpedo Level	1
GENERIC		Compass (NEON.TIS.5.1042: All photosynthetically active radiation (PAR) sensors shall be oriented such that the cable points to true North within ±5°.)	1
NEON ENG	0321020000	LI-191 Leveling Cover (the leveling mount for the QLS in Figure 78)	A/R
<b>Consumable Items</b>			
3M	<i>See below</i>	ESD Bags for Sensor Refresh	1
	MX105865	3M Bag, ESD Shielded, 8 inch x 11 inch, Cushioned	A/R
	MX105931	3M Bag, ESD, Static Shield, 6 x 8 Inches, Zip Closure, Non-Cushioned	A/R
	MX105864	3M Bag, ESD Shield, 6 Inch X 7 Inch, Cushioned	A/R
	MX105866	3M Bag, ESD Shielded, 14 Inch X 15 Inch Cushioned	A/R



Title: NEON Preventive Maintenance Procedure: Radiation Sensors		Date: 04/12/2022
NEON Doc. #: NEON.DOC.004429	Author: R. Zulueta, M. Cavileer, R. Willingham	Revision: C


P/N	MX/NEON	Description	Quantity
	MX105935	3M Bag, ESD, Static, 15 x 18 Inches, Zip-Closure Top	A/R
	MX110345	3M Bag, ESD Static Shield, 12 inch x 12 inch, Zip Closure	A/R
GENERIC		Towel (To Leverage Grip or Wipe-off Items)	1
GENERIC		Microfiber/Lint-free cloth	1-2
1HAB2	MX104219	Grainger Red Inspection Tag, Paper, Rejected, PK1000	A/R
Various	CB08180000	Kit, Grape Dust Caps	4-6
GENERIC		Multi-colored Zip-ties or Electrical Tape (to label Heater Ports)	4 Colors
GENERIC		Black Zip ties (to re-dress cables)	A/R
<a href="#">80337</a>	0355220000	SAF-T-LOKSAFTEZE Food/Drug Grade Anti-Seize (for AIS stainless steel Infrastructure) <i>Temp Range: Lubricant -65 to 450°F   Anti-Seize -65°F to 2600°F</i>	1
<a href="#">37230</a>		Loctite QuickStix Silver Anti-Seize LB 8060 (for TIS Infrastructure)	1

**Resources**

NEON Data Monitor, Inclinator & SSH/TEP Software Resources: <a href="#">N:\Common\SYS\LabVIEW Programs</a>
TEP Programs - PuTTY: <a href="http://www.putty.org/">http://www.putty.org/</a> or MobaXterm: <a href="https://mobaxterm.mobatek.net/">https://mobaxterm.mobatek.net/</a>
The SAS Report: <a href="http://sas.ci.neoninternal.org/">http://sas.ci.neoninternal.org/</a>
Site Configuration Static IP Device List: <a href="#">N:\Common\SYS\Site Network Configurations</a>
FTDI Drivers: <a href="http://www.ftdichip.com/FTDrivers.htm">http://www.ftdichip.com/FTDrivers.htm</a> (use with Inclinator if hardware requires this driver to function)
NEON Document Warehouse: <a href="https://neoninc.sharepoint.com/sites/warehouse/Documents/Forms/AllItems.aspx">https://neoninc.sharepoint.com/sites/warehouse/Documents/Forms/AllItems.aspx</a>
NEON Drawing Warehouse: <a href="https://neoninc.sharepoint.com/sites/warehouse/Drawings/Forms/AllItems.aspx">https://neoninc.sharepoint.com/sites/warehouse/Drawings/Forms/AllItems.aspx</a>

A/R = As Required – Amount varies per site. Ordering amount is at the discretion of the Domain or FOPS Leadership.

 **Note:** When working on power systems, use tools with insulated handles. Always shut down the power prior to removing or replacing any components.

 **Note:** Maintain legible labels on sensor and subsystem cables.

**6.2 Removal and Replacement Procedure**

The FOPS Domain Manager is responsible for managing the removal and replacement of the sensors on site for preventive maintenance and/or sensor swaps and manages field calibration and validation of sensors, as appropriate. The NEON project Calibration, Validation and Audit Laboratory (CVAL) is responsible for the calibration and validation of select sensors and manages Domain sensor refresh (swap) schedules.

To minimize data downtime and optimize the availability of sound data, coordinate instrumentation and subsystem annual calibration, validation and preventive maintenance requirements to occur within the same timeframe. See **Table 8** for sensor refresh requirements for the sensor and subsystem infrastructure for the Radiation Sensors at both TIS and AIS sites. **Table 16** in *Section 6.6 Cleaning & Packaging of Returned Sensor* complements the information in **Table 8**.




**Table 8. Radiation Sensor Refresh Requirements.**

INSTRUMENT	LOCATION		TIMEFRAME			COMMENTS
	CVAL	FIELD	BIWEEKLY	ANNUAL	NA	
Concord (24V) Grape	X			X		Employ ESD Protocols. Cap all ports.
Merlot (12V) Grape	X			X		Employ ESD Protocols. Cap all ports.
Primary Pyranometer (CMP22)	X			X		Return to CVAL per Domain/Site Sensor Refresh Schedule. Clean the fan screen during decontamination. Reference Figure 107 and Figure 108. Employ ESD Protocols.
Sunshine Pyranometer (SPN1)	X			X		Return to CVAL per Domain/Site Sensor Refresh Schedule. Reference Figure 109. Employ ESD Protocols.
Biological Temperature Sensor (SI-111)	X			X		Return to CVAL per Domain/Site Sensor Refresh Schedule. Place a green protective cap over sensor end of sun shield. Reference Figure 114. Employ ESD Protocols.
PAR Quantum Sensor (PQS1)	X			X		Return to CVAL per Domain/Site Sensor Refresh Schedule. Place a black cap over



Title: NEON Preventive Maintenance Procedure: Radiation Sensors		Date: 04/12/2022
NEON Doc. #: NEON.DOC.004429	Author: R. Zulueta, M. Cavileer, R. Willingham	Revision: C

INSTRUMENT	LOCATION		TIMEFRAME			COMMENTS
	CVAL	FIELD	BIWEEKLY	ANNUAL	NA	
						the diffuser. Reference Figure 115. Employ ESD Protocols.
Net Radiometer (NR01)	X			X		Return to CVAL per Domain/Site Sensor Refresh Schedule. Place a black cap over each diffuser. Reference Figure 116. Employ ESD Protocols.
Quantum Line Sensor (LI-191)	X			X		Return to CVAL per Domain/Site Sensor Refresh Schedule. Employ ESD Protocols. Reference Figure 118.

 **Note for AIS:** Maintain the AIS sensor sets asset tags in the AIS Buoy battery box or closest onshore AIS device post (e.g., the Aquatics Portal or S-1/S-2 Combo Box). Use option one or option two, do not split up tags between the two options. **Do not send a sensor to CVAL without its asset tag.**

### 6.3 TIS Radiation Sensor Removal and Replacement Procedures

#### 6.3.1 TIS Tower Radiation Sensors

##### 6.3.1.1 Tower Profile Measurement Level

The TIS profile MLs booms (and ML1 arbors for specific sites) contains the PAR Quantum Sensor (PQS1), Biological Temperature Sensor (SI-111) and their subsystem Concord Grape (24V) (**Figure 43**). Reference **Table 7** for equipment and materials.



Figure 43. Tower Profile ML Radiation Booms/Arbor: Biological Temperature Sensor (SI-111) and PAR Quantum Sensor (PQS1)

Table 9. Tower Profile ML Net Radiometer, PAR Quantum Sensor Removal and Replacement Procedure | TIS Tower.

**STEP 1** | Power down the profile ML or for short towers, the combined ML. *Reference Appendix 8.8– How to Power Down a Tower Measurement Level (ML).* Disconnect the communication box heater (12-3) ports before servicing or replacing sensors for sensor refresh.



Figure 44. ML1 Profile Radiation and Biological Temperature Sensor Combo

**STEP 2** | Wear the appropriate Personal Protective Equipment (PPE) to access the sensors on the ML.

If Technicians are unable to access ML1 arbor/boom (Figure 44 displays a ML1 boom) or ML2 radiation sensors from the ground or with a ladder, climb the tower and bring in the profile boom arm via its winch to reach the radiation sensors for removal and replacement (Sensor Refresh).

***For combined booms, disconnect the 240V AC heater power cables from the Comm box before retracting boom.***





Figure 45. Subsystem Concord Grape on Profile Boom Arm

**STEP 3** | The Biological Temperature and PAR Sensors share a Concord Grape (24V) (Figure 45). Disconnect Eth-to-Comm (RJF) and sensor connections from the Concord Grape (24V) per AD [09].

Cut zip ties to undress cables, as appropriate.

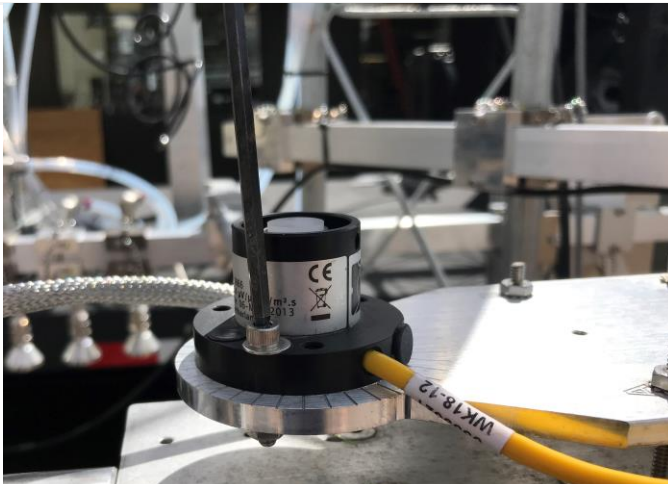


Figure 46. Remove PAR Quantum Sensor with 5/32" Allen Wrench

**STEP 4** | Remove the PAR sensor with a 5/32" Allen wrench (Figure 46 and Figure 47).



Figure 47. 5/32" Allen Wrench




**STEP 5** | Remove the Biological Temperature Sensor from the profile ML by removing the U-bolt using a 1/2" wrench (Figure 48).

***i** Note: Figure 48 is a Mobile Deployment Platform (MDP) Rohn Tower mount, which is similar to the mount at TIS sites for the Apogee. The nuts/screws and their placement are the same. The MDP is part of the [NEON project's Assignable Assets program](#), which may involve FOPs personnel depending on location and private investigator requirements per deployment.*




Figure 48. Remove U-Bolts with Speed Wrench

**STEP 6** | Use the reverse order to reinstall the “refreshed” sensor. For the Biological Temperature Sensor, ensure the cable end is flush with the edge of the V-Clamp.

 **PRO TIP:** Apply anti-seize compound in Table 7 to threads of all mounting fasteners to ensure easier future removal/replacement.

**STEP 7** | Level the PAR sensor leveling plate post-sensor reinstallation using the [Inclinometer \(CA02630010 Assembly, Inclinometer, 6ft non-rotating with 0316280000 Sensor Inclinometer 0750 Series Single and Dual Axis Stand Alone\)](#) when the boom arm is at full extension. FOPs may require the Future Technology Devices International ([FTDI](#)) [Windows Driver](#) to run the Inclinometer software on specific hardware. Continue to the next step for instructions on leveling the PAR sensor using the inclinometer. Use Figure 49 to reference PAR sensor mount components.

 **Note:** Leveling the boom is also critical to collect accurate radiation measurements at the angle to which the PAR instrument is set. A non-level boom arm compromises data quality. Use the Inclinometer to read the position of the boom and each PAR sensor relative its leveling plate.

 **PRO TIP:** Noting the change in the inclinometer readings when the boom is in its retracted and extended positions helps you make progress with each leveling iteration.

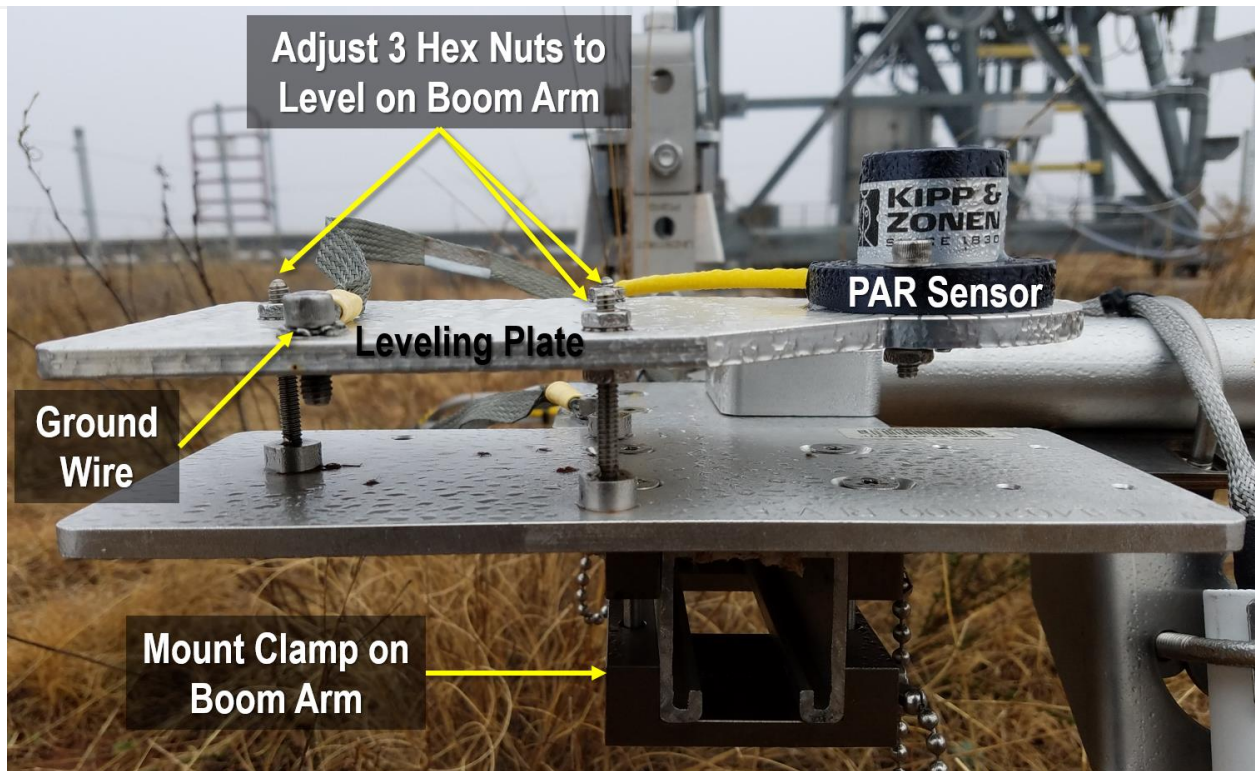


Figure 49. PAR Quantum Sensor Leveling Plate and Mount Components



**PRO TIP:** It is harder to level the PAR Quantum Sensor if Technicians remove the entire mount from the boom arm. If Technicians must remove the mount, remove the ground wire and the mount clamp with a hex wrench to remove the entire mount from the boom arm (Figure 49). Re-level using the hex wrenches and the following process in Steps 7 - 8.



Figure 50. Inclinometer on the PAR Quantum Sensor Leveling Plate (D08 DELA)

**EXAMPLE EQUATION:**

Initial Extension Measurement

↓

0.8° PITCH

↻

1.6° ROLL

Figure 51. Initial Extension Measurement

**STEP 8** | Place the Inclinometer on the PAR sensor leveling plate (Figure 50) and secure with the two 8-32 screws. Conduct the following steps to level the pitch and the roll of the PAR sensor:

1. For ML3 and above, extend the boom arm. For ML2, skip this step unless the boom arms were in use for this procedure due to height/unforeseen circumstances (e.g., plethora of poison ivy or other unsafe conditions).
2. With the boom arm at extension, take the first reading from the inclinometer. (**Initial Extension Measurement in Figure 51 example**)
3. Bring the boom arm in again, and take another reading. (**Initial Retraction Measurement in Figure 52 example**)
4. Deduct the delta between the two readings. (**Initial Retraction – Initial Extension = DELTA Offset Measurement in Figure 53 example**)
5. Adjust the PAR Leveling Plate to equal the delta measurement with a digital level to monitor the adjustments to pitch and roll of the PAR sensor. (**DELTA Offset Measurement = Digital Level Measurement for PAR Leveling Plate in Figure 54 example**)
6. Verify adjustment by collecting another reading from the inclinometer. (**Verify PAR Leveling Plate = DELTA Offset Measurement**)
7. Extend the boom arm and collect an additional reading to verify the PAR is  $0 \pm 1^\circ$ . (**Second Extension PAR Leveling Plate Measurement**)



### Initial Retraction Measurement



↓ **1.3° PITCH**  
↻ **0.1° ROLL**

Figure 52. Initial Retraction Measurement

### Initial Retraction – Initial Extension

**1.3° PITCH – (0.8° PITCH) = + 0.3° PITCH**  
**0.1° ROLL – (1.6° ROLL) = - 0.7° ROLL**

Figure 53. Initial Retraction – Initial Extension = DELTA Offset Measurement

### Desired Delta Offset Measurement = Digital Level Measurement for PAR Leveling Plate

↓ **+ 0.3° PITCH**      ↻ **- 0.7° ROLL**

Figure 54. Desired DELTA Offset Measurement = Digital Level Measurement for PAR Leveling Plate

- a. If this second reading using inclinometer is not zero, this measurement is the new baseline for Step 2.
- 8. If the PAR is not level, repeat Steps 2 - 7 until the PAR sensor is  $0 \pm 1^\circ$ .
  - a. If unable to level the PAR sensor, submit a ticket in the NEON Reporting/Issue Management System (e.g., ServiceNow) with measurements and issues encountered when attempting to level the sensor.

**PRO TIP:** For ML1/ML2 (as applicable), use a telescoping/inspection mirror to check the Surface Radiation sensor's bubble level.

**STEP 9** | Connect Eth-to-Comm (RJF) and sensor connections from Grape per AD [09]. Re-dress cables with zip ties, as appropriate. Create slack in the cables to make drip-loops at the sensor and the GRAPE, with no stress on any connection. Adjust slack to make all cables agree. Do not “reverse loops” or “change direction” if possible. Never twist cables. Remove Grape for Sensor Refresh; *reference Section 6.5 Grape Removal and Replacement Procedure on page 95*. For combined booms, disconnect the ATS 240V heater power cable to the Comm box after extending the boom.

**STEP 10** | Restore power to the sensor/ML.

**STEP 11** | Verify the sensors show up in the [SAS Report](#) the next day.

#### 6.3.1.2 Tower Top Measurement Level

The TISTower Top ML radiation boom arm contains the Net Radiometer with a Merlot Grape (12V) and splitter and two PAR Quantum Sensors with a Concord Grape (24V). The Sunshine Pyranometer and Primary Pyranometer sensor assembly reside together on the Tower Top ML railing with a separate Merlot Grape (12V) for each sensor. **Figure 55** shows each sensor and their respective placement and



subsystem Grape locations. The Primary Pyranometer is only present at TIS Core sites (see Appendix 8.3). TIS tower sites primarily have the Sunshine Pyranometer. *Reference the site As-Built documentation to review the complete list of sensors and subsystems at this site via the [NEON Document Warehouse](#).* Reference **Table 7** for equipment and materials to remove these sensors.



Figure 55. Tower Top ML Combined Boom Arm with Net Radiometer & PAR Quantum Sensor (D08 DELA) and Railing with the Primary Pyranometer and Sunshine Pyranometer (D08 TALL)

**Table 10. Tower Top ML Net Radiometer, PAR Quantum Sensor, Primary Pyranometer, and Sunshine Pyranometer Removal and Replacement Procedure | TIS Tower**

<p><b>STEP 1</b>   Power down the tower top ML. <i>Reference Appendix 8.8 – How to Power Down a Tower Measurement Level (ML).</i> Disconnect the communication box heater (12-3) ports before servicing or replacing sensors for Sensor Refresh.</p>
<p><b>STEP 2</b>   Wear the appropriate PPE to access the sensors on the Tower Top ML. Bring in the combined boom arm to reach the Net Radiometer and PAR Quantum Sensor for Sensor Refresh. The sensors on the railing are easy to reach from the ML deck.</p>



Figure 56. Tower Top ML Combined Boom Radiation Sensor Subsystem Grapes (D06 KONA)

**STEP 3a** | Disconnect Eth-to-Comm (RJF) cable and sensor connections from the Merlot Grape (12V) (CB14023600) and Concord Grape (24V) (CB14043600) per AD [09] and **CD00260010 Assembly, NR01 Sub-Assembly 2 Grapes** on the combined boom arm (Figure 56). The Net Radiometer Splitter sits in front of the of the two Grape mounts, between the Grapes and the Net Radiometer (not viewable in Figure 56)

Cut zip ties to undress cables, as appropriate.

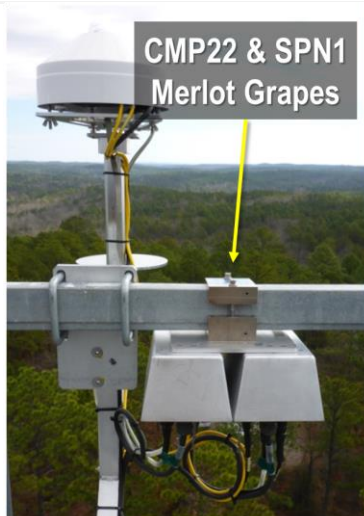


Figure 57. Tower Top ML Railing Radiation Sensor Merlot Grapes (D08 TALL/D19 HEAL)


**STEP 3b** | Disconnect Eth-to-Comm (RJF) cable and sensor connections from the Merlot Grape(s) (12V) per AD [09] on the tower top railing (Figure 57).

Cut zip ties to undress cables, as appropriate.



Figure 58. Remove the Primary Pyranometer from Mount Plate

**STEP 4a** | **TIS CORE SITES ONLY:** Remove the two wingnuts (Figure 58) securing the Primary Pyranometer to the Pyranometer mount plate (0319420000) and remove the splitter with the sensor from the tower top railing mounts.

 **PRO TIP:** Snap a picture of assemblies prior to removal to have for reinstallation reference.

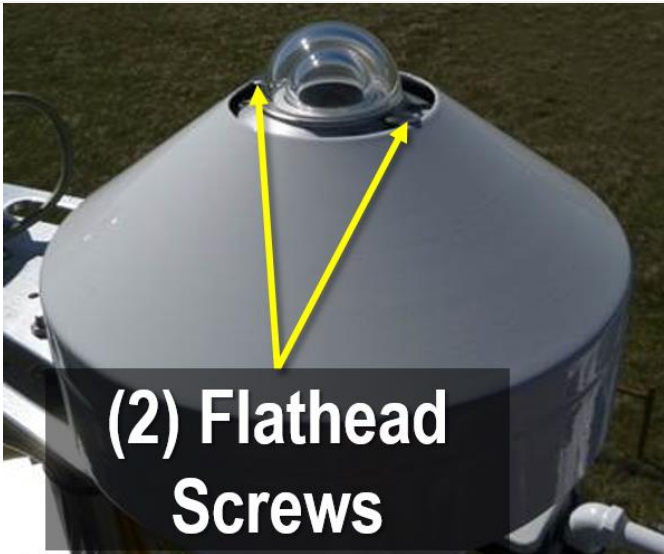


Figure 59. Use Flathead Screwdriver to Solar Shield

**STEP 4b | TIS CORE SITES ONLY:** On the Primary Pyranometer, the two (2) mounting bolts (0306410016) and the lock washers move to the new “refreshed” Primary Pyranometer.

The adjustable feet on the “refreshed” Primary Pyranometer must approximately match the length of the old ones to minimize the amount of leveling.

Remove the Solar Shield to access the mounting bolts, if necessary, with a flathead screwdriver (see Section 5.5.3.1.1 and Figure 59).

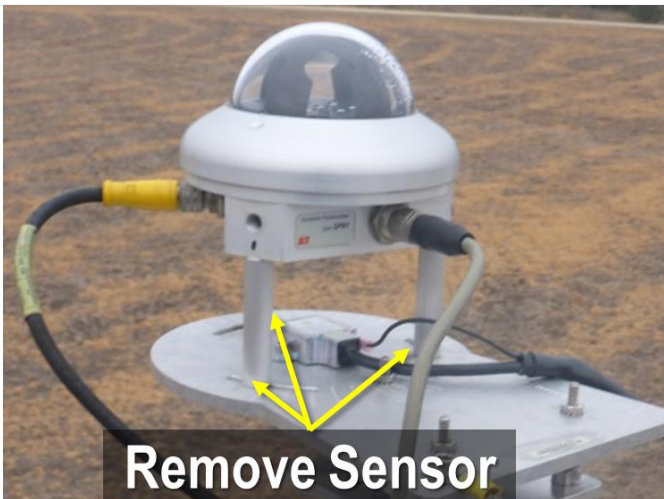


Figure 60. Remove SPN1 Sensor from Mount Plate

**STEP 4c |** Remove the Sunshine Pyranometer from the tower top railing Pyranometer mount plate (0319420000) (Figure 60). Unthread the three Screw Socket Head, M5, Stainless Steel, 70 mm (0340190000) screws.

These three 70 mm screws (0340190000) and flat washers (0320440000), and standoffs (0319810000) move to the new “refreshed” Sunshine Pyranometer .

**STEP 5a |** Retract the tower top pivot boom with the radiation and/or temperature sensors. Use two technicians to conduct this procedure. Use Figure 61 with the procedure as an overview of component order of operations and location.

***Disconnect the 240V heater cables from the Comm box before retracting the boom.***



Figure 61. Components in Order of Operation to Retract the Tower Top Boom



Figure 62. Remove the First Pin from the Longer Boom Arm

**STEP 5b** | Remove the first pin in Figure 61. Figure 62 displays a close up of this pin on a different tower top boom. This boom arm has the instrument mounts for each tower top boom assembly. (This boom arm has the gas lines on it for the Eddy Covariance Turbulence Exchange (ECTE) system tower top boom.)



Figure 63. Remove the Second Pin from the Crossbeam (D06)

**STEP 5c** | Remove the second pin in Figure 61 from the boom arm horizontal support adjacent from the instrumentation. For this procedure, Figure 63 is the crossbeam.





Figure 64. Move Crossbeam Toward Tower Top Railing



Figure 65. Guide the Boom Arm Toward the Tower Top (D06 KONA)

**STEP 5d** | Slide the crossbeam off its support, and pull it toward the tower top railing (Figure 64 and Figure 65). This step may require lightly pushing in and, with more force, down to free and leverage the instrumentation end of the boom toward the tower and onto the crossbeam that acts as a second support to rest the heaviest portion of the boom arm (the sensor end) as it is transitioned towards the tower. Use care to minimize the vertical movement of the upper crossbeam, since its outboard end is not designed for this type of twisting load.

The mount end of the boom that connects to the tower top railing will swing out away from the tower top as the end with sensors comes toward the tower top railing to rest upon the crossbeam.

**PRO TIP:** When pivoting the boom (without its support) away from the tower, do not pivot the sensor end of the boom past its support arm AWAY from the tower. If the sensor end of the boom without its support gets too far over the edge, its weight may break the pivot pin and fall off. Only rotate the entire boom (boom and support arm) on its hinges outside of the tower. This is necessary for tower top booms that mount to the same side of the railing and face the same direction.

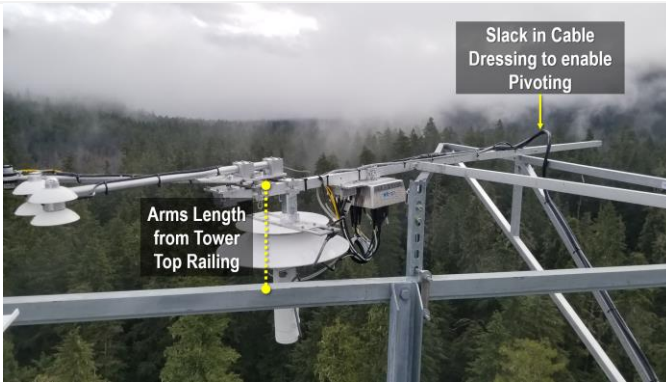


Figure 66. Tower Top Radiation Boom Pivoting Toward Tower Deck

**STEP 5e** | The Aspirated Air Temperature Shield (AATS) blocks the ability to move the sensors over the Tower Top deck; however, the radiation sensor assembly mounts are retracted within arm's length to conduct Sensor Refresh (Figure 66).



Figure 67. Mechanical Stop for Boom (D02 BLAN)

**STEP 5f** | If the crossbeam cannot rotate the boom arm toward the tower top (and rest boom arm sensor end on the tower top railing) by pivoting, the triangular boom support can be pivoted in towards the tower rail by following the sequence noted below.

Remove the two mechanical stops on the boom support mount (**do not remove the hinge**). The "L" brackets bolt the boom support to the boom mount near the hinges; Figure 67 displays an example of one.



Figure 68. Crossbeam Thumbscrew

**STEP 5g** | Remove the thumbscrew at the tower end of the lower crossbeam (Figure 68).



Figure 69. Rotate Assembly Toward Tower Top Railing/Deck

**STEP 5h** | Rotate the entire assembly (boom and support arm) toward the tower top deck (Figure 69). Conduct preventive maintenance/Sensor Refresh.

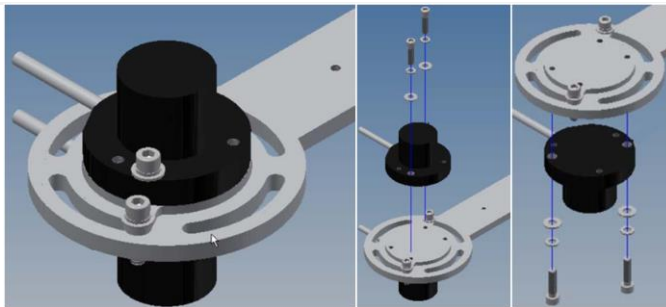



Figure 70. Remove the Two Screws for Each PAR Sensor (Source: AD [21])

**STEP 6a** | Remove the PAR sensors from the tower top radiation boom arm. Remove the two hex screws (Screw Socket Head 10-24) on each side securing each PAR sensor to the radiation mount (Figure 70).

 **PRO TIP:** Use [AD \[21\]](#) for additional guidance.

**STEP 6b** | Remove the NR01 Net Radiometer and its splitter from the tower top radiation boom arm (in Figure 73 where the sensor adjusts for roll on page 76). Remove the two setscrews on the underside of the sensor that secure the Net Radiometer to its extension arm (the setscrews that adjust for roll).

***Never remove the Net Radiometer for Sensor Refresh from the setscrews that adjust for Pitch. Only remove the setscrews that adjust for roll when conducting Sensor Refresh. The assembly is incomplete without this piece.***

 **PRO TIP:** Report objects that cast shadows or reflections on these instruments.<sup>4</sup>

**STEP 7** | Use the reverse order to reinstall each “refreshed” radiation sensor. For the Sunshine Pyranometer, the three (3) existing 70 mm screws (0340190000) and flat washers (0320440000), and standoffs (0319810000) must be moved to the new “refreshed” Sunshine Pyranometer sensor unit. For the Primary Pyranometer, the two (2) existing mounting bolts (0306410016) and the lock washers move to the new “refreshed” Primary Pyranometer.

<sup>4</sup> NR01 Four-Component Net Radiation Sensor <https://s.campbellsci.com/documents/eu/manuals/nr01.pdf> page 8.



Reference [AD \[12\]](#) for the South East Radiation Installation Procedures for the Primary Pyranometer and Sunshine Pyranometer sensors and [AD \[13\]](#) for the South West Radiation Installation Procedures for the Net Radiometer and PAR Quantum Sensors.

**PRO TIP:** Apply anti-seize compound in Table 7 to threads of all mounting fasteners to ensure easier future removal/replacement.



Figure 71. Primary Pyranometer Yellow Cables (CVAL)

**TIS CORE SITES ONLY:** In the event the Primary Pyranometer yellow cables require reconnecting: please be aware, each cable uses the same connector (Figure 71). Mixing up these cables **will** cause irreparable damages to the sensor. Maintain these labels in the event reinstallation/corrective actions require disconnecting/reconnecting under the sensor cover.

**STEP 8 | TIS CORE SITES ONLY:** Per [AD \[12\]](#), adjust the Pyranometer mount plate (0319420000) to ensure that it is level on both axes (front-to-back and side-to-side) using a digital level. Adjust the mounting bolts, if necessary.

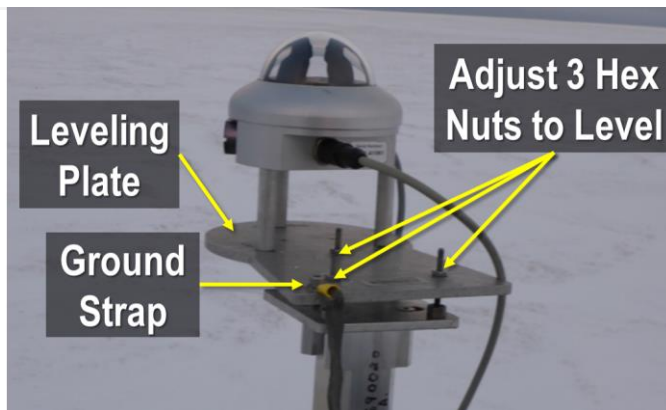


Figure 72. Sunshine Pyranometer Leveling Components & Ground Strap (D19 HEAL)

**STEP 9b |** Level the Sunshine Pyranometer on both axes (front-to-back and side-to-side) using a digital level.

Adjust the Sunshine Pyranometer leveling plate by the hex nuts using a hex wrench (Figure 72). Use a digital level to monitor leveling adjustments.



Figure 73. Sensor Leveling for Net Radiometer and PAR Sensor

**STEP 10** | Level the Net Radiometer and PAR Quantum Sensor relative to the extension arm bar that attaches to the assembly's leveling plate. Use the bubble level on the sensor or digital level on the two PARs relative to the extension bar (Figure 73).

For the Net Radiometer, adjust the two setscrews on the underside of the sensor to control for roll and adjust the two setscrews on the front of the sensor to control for pitch relative to the extension bar. This sensor also contains a bubble level under the cap (Figure 73). A digital level is also acceptable for use.

**Note:** The Net Radiometer pitch and roll adjustment areas are the same across all TIS/AIS sites.

**STEP 11** | Level the PAR sensor leveling plate and Net Radiometer post-sensor reinstallation using the [Inclinometer](#) when the boom arm is at full extension to level each extension arm supporting the sensor. FOPs may require the [FTDI Driver](#) to run the Inclinometer software on specific hardware. Reference Table 9. Tower Profile ML Net Radiometer, PAR Quantum Sensor Removal and Replacement Procedure | TIS Tower: **STEP 8**. Use Figure 74 to reference inclinometer for the PAR Quantum Sensor and Net Radiometer on the tower top ML radiation boom arm.

**Note:** Leveling the boom is also critical to collect accurate radiation measurements at the angle to which the PAR instrument is set. A non-level boom arm compromises data quality. Use the Inclinometer to read the position of the boom and each PAR sensor relative its leveling plate.

**PRO TIP:** Noting the change in the inclinometer readings when the boom is in its retracted and extended positions helps you make progress with each iteration.

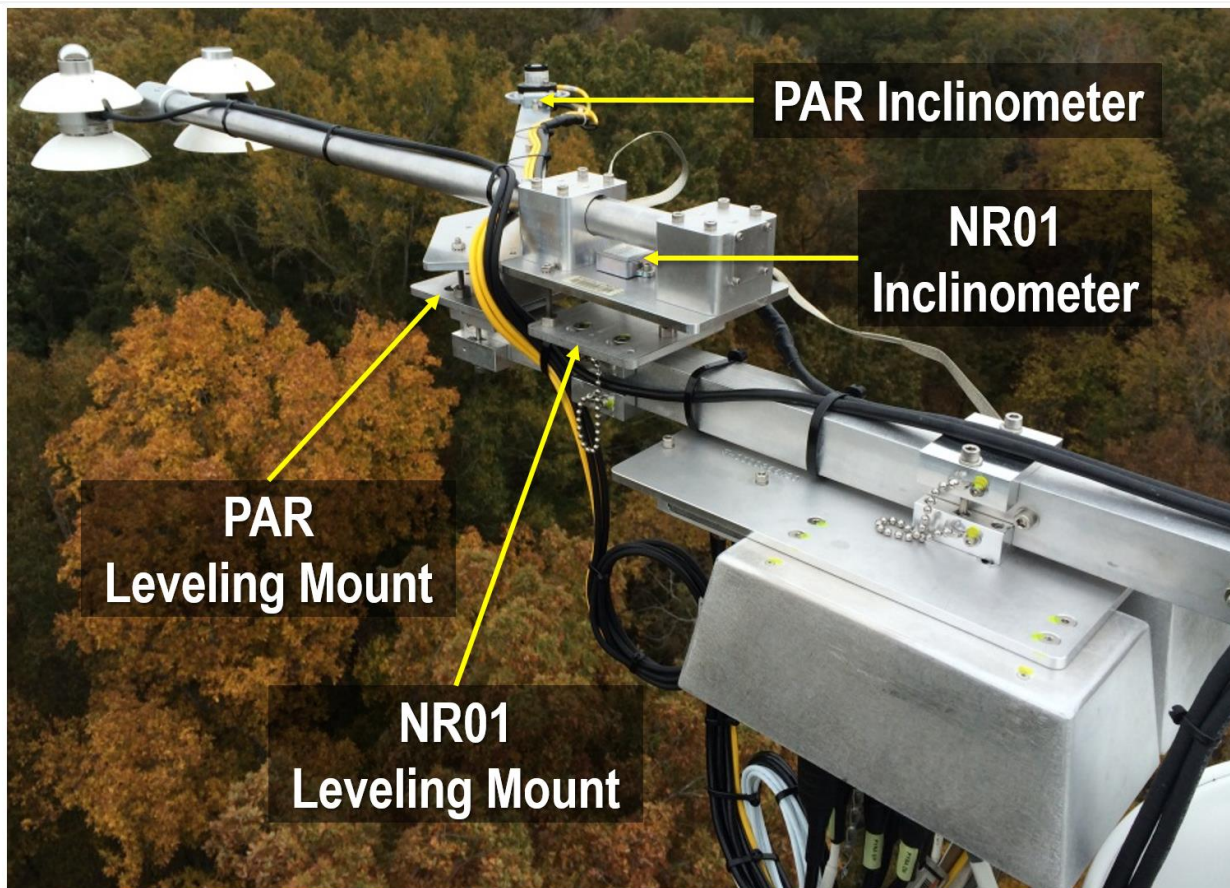



Figure 74. Level the Net Radiometer and PAR Quantum Sensors using the Inclinator (D08 DELA)

**STEP 12** | Connect sensors and Eth-to-Comm (RJF) connections to Grape per AD [09]. Re-dress zip ties, as appropriate. **Create slack in the cables to make drip-loops at the sensor and the Grape, with no stress on any connection. Add slack where booms pivot and adjust slack to make all cables agree. Do not “reverse loops” or “change direction” if possible. Never twist cables.** Figure 56 displays cable routing for the Primary Pyranometer and Sunshine Pyranometer. Remove Grape for Sensor Refresh; *reference Section 6.5 Grape Removal and Replacement Procedure on page 95.*

 **PRO TIP:** Per [AD \[12\]](#), form drip loops below its Grape after the cable connects securely to the Grape. This ensures that moisture on the cable will not flow to the connector.

**STEP 13** | Restore power to the sensors/Tower Top ML.

**STEP 14** | Verify the radiation sensors show up in the [SAS Report](#) the next day.

### 6.3.2 TIS Soil Array Radiation Sensors

The TISoil Array contains a Quantum Line Sensor (QLS), Net Radiometer, and Biological Temperature Sensor, and their subsystem Grape. The Quantum Line Sensor, Net Radiometer and Biological



Temperature Sensor share a Merlot Grape (12V) in primarily Soil Plot (SP) 1, 3, and 5. **Figure 75** is the Biological Temperature Sensor and Net Radiometer with the Merlot Grape (12V) on the Radiation Arbor in SP3 (see AD [20] for the Radiation Arbor verification procedures).



**Figure 75.** Radiation Arbor with Merlot Grape, Net Radiometer (CF05930000) and Biological Temperature Sensor (CF05940000) in Soil Plot 3 (D14 JORN)

**Figure 76** displays the Quantum Line Sensor in SP3.



**Figure 76.** A Quantum Line Sensor (CF05840000) in Soil Plot 3 (D08 TALL)

Some sites may find these sensors are present in different Soil Plots per site-specific requirements. Reference the site As-Built documentation to review the complete list of sensors and subsystems at this site via the [NEON Document Warehouse](#). Reference **Table 7** for equipment and materials.

**Table 11.** Quantum Line Sensor, Net Radiometer and Biological Temperature Sensor Removal and Replacement Procedure | TIS Soil Array.

**STEP 1** | Power down the soil plot. Reference Appendix 8.10 – How to Power Down a Soil Plot (SP) Power Box. Disconnect the communication box heater (12-3) ports before servicing or replacing sensors for sensor refresh.



**STEP 2** | At the device post at the relevant soil plot, Technicians must walk towards the soil plot following the route of the conduit from the device post to the soil plot arbor remaining at least 1m (~3.3') outside of the soil plot at all times. Always travel the shortest route towards the assembly that remains at least 1m outside of the soil plot.

**FOPS must remain at least 1m outside of the plot unless maintenance activities require close contact with a sensor. When approaching a soil plot, do not step or place tools on the ground within 30cm (~1') of any sensors within the soil plot to minimize disturbance to the soil and vegetation surrounding the sensor.**

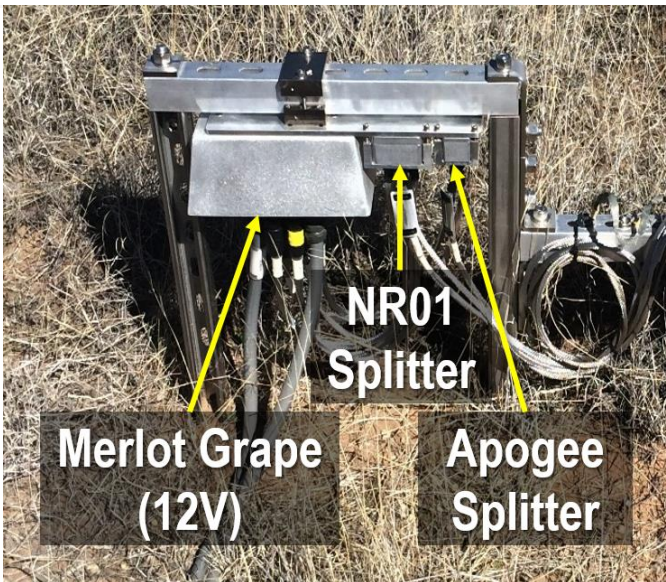


Figure 77. Radiation Arbor (D14 JORN)

**STEP 3** | Disconnect Eth-to-Comm (RJF) cable and sensor connections from the Merlot Grape (12V) per AD [09]. The Grape may either reside near the sensors on the Radiation Arbor (Figure 75 on page 78) or from a nearby Arbor along the edge of the soil plot (Figure 77).

The Quantum Line Sensor, Biological Temperature Sensor, and Net Radiometer share the same Merlot Grape.

**STEP 4a** | Remove the Biological Temperature Sensor and its splitter. Remove the two 3/8" U-bolt nuts using a speed wrench and unscrew the splitter from the arbor.

**STEP 4b** | Remove the Net Radiometer and its splitter. Remove the two Allen set screws that secure the sensor to its extension arm and in the same area that adjusts for roll when leveling. **Never remove the Net Radiometer for Sensor Refresh from the setscrews that adjust for Pitch. Only remove the setscrews that adjust for roll when conducting Sensor Refresh. The assembly is incomplete without this piece.** Unscrew the splitter from the arbor.

**STEP 4c** | Remove the Quantum Line Sensor. Remove the sensor portion from the mounting bracket and unscrew the other end from the split lock washer and fender (circled in Figure 78).



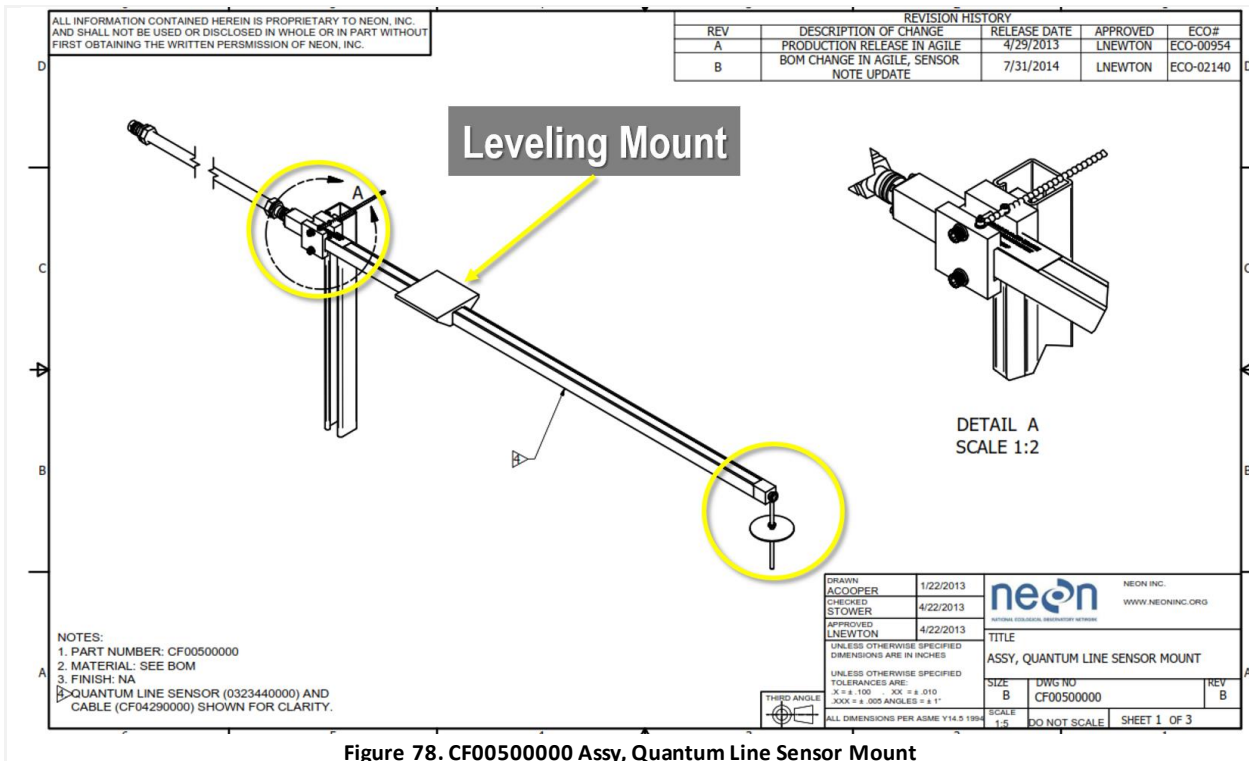


Figure 78. CF00500000 Assy, Quantum Line Sensor Mount

**STEP 5** | Use the reverse order to reinstall each “refreshed” sensor. Reinstall the Quantum Line Sensor. Ensure there is a 75 cm distance between the Net Radiometer and the Quantum Line Sensor. Mount the Quantum Line Sensor to the Unistrut post in the soil plot. Ensure the beginning of the Quantum Line Sensor white sensor face is at least 2 inches away from the Unistrut post. For the Quantum Line Sensor mounting hardware, hand tighten to capture the Quantum Line Sensor within the mounting bracket using (2) ¼-20 screws after applying thread lubricant (see Table 7 for lubricant type). Reinstall the Net Radiometer to the extension rod and secure view the two setscrews on the underside of the sensor. Do not completely tighten until leveling is complete. Reinstall the Biological Temperature Sensor. Rotate the Biological Temperature Sensor slightly as necessary to avoid clamping the nylon shield set screw against the clamp base. Hand tighten the two 3/8” U-bolt nuts until leveling is complete (next steps).

Reference [AD \[18\]](#) to verify the Quantum Line Sensor installation (Soil Radiation Quantum Line Sensor Formal Verification Procedures). Reference [AD \[17\]](#) and [AD \[19\]](#) to verify the Net Radiometer and the Biological Temperature Sensor installations.

**STEP 6** | Level each sensor using a digital level. The digital level should read 68° when the Biological Temperature Sensor Mounting Bracket meets the 22° ±1 from vertical requirement. Level the Quantum Line Sensor using its leveling mount (in Figure 78) to within ±1° on both axes. Adjusting the upper and lower nuts around the fender washer allows small adjustments to level the Quantum Line Sensor. Level the Net Radiometer referencing Figure 73 and Figure 88 for guidance on how and where to level the sensor on both axes. Ensure the pitch of the instrument is close to 90° as possible to the extension rod.



**STEP 7** | Tighten hardware components for each soil sensor post-leveling. For the Quantum Line Sensor, do not overtighten the clamp bolts. Recommend hand tightening the fender end of the sensor instead of over-torquing the reinstallation of this sensor. For the Biological Temperature Sensor, tighten the two 3/8" U-bolt nuts enough to crush the split lock washer, then another 1/6 turn of the nut. Do not over tighten. Attach the ground straps from the Net Radiometer and the Biological Temperature Sensor to the arbor.

**STEP 8** | Connect sensors and Eth-to-Comm (RJF) connection to Grape per AD [09]. Re-dress zip ties, as appropriate. **Create slack in the cables to make drip-loops at the sensor and the Grape, with no stress on any connection. Adjust slack to make all cables agree. Do not "reverse loops" or "change direction" if possible. Never twist cables.** Remove Grape for Sensor Refresh; *reference Section 6.5 Grape Removal and Replacement Procedure on page 95.*

**STEP 9** | Restore power to the Soil Plot.

**STEP 10** | Verify sensors show up in the [SAS Report](#) the next day.

## 6.4 AIS Radiation Sensor Removal and Replacement Procedures

### 6.4.1 AIS Aquatic Met Station Radiation Sensors

The Aquatic Met Station contains the Net Radiometer and PAR Quantum Sensor on the Radiation Boom arm from the Met Station mast. Reference **Table 7** for equipment and materials.



Figure 79. AIS Aquatic Met Station Radiation Boom Arm with PAR Quantum Sensor and Net Radiometer (D14 SYCA)



**Table 12. Net Radiometer and PAR Quantum Sensor Removal and Replacement Procedure | Aquatic Met Station.**

**STEP 1** | Power down the Aquatic Met Station. *Reference Appendix 8.9 – How to Power Down an AIS Device Post: Aquatic Met Station.* Disconnect the communication box heater (12-3) ports before servicing or replacing sensors for sensor refresh.

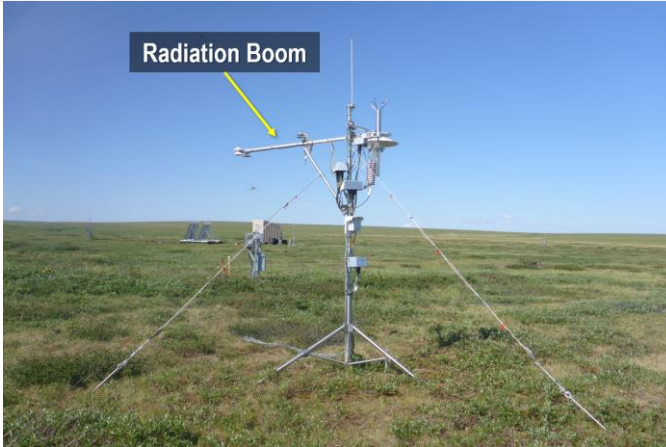


Figure 80. Aquatic Met Station Radiation Boom (D18 OKSR)

**STEP 2** | Access the Radiation Boom Arm via a ladder (recommended) and/or remove the Radiation Boom from the Mast to access sensors. Consult with the NEON Safety Office to determine the safest method to conduct Sensor Refresh procedures herein.


 **PRO TIP:** In the event the Radiation Boom requires removal, use a [bump stop](#) on the mast to aid reinstallation in the same relative position (see AIS Buoy procedure for examples with its Radiation Boom).



Figure 81. PAR Quantum Sensor and Net Radiometer Merlot Grape (12V)

**STEP 3** | The PAR (PQS1) and Net Radiometers share a Merlot Grape (12V) (Figure 81). Disconnect Eth-to-Comm (RJF) and sensor connections from the Merlot Grape (12V) per AD [09].

Cut zip ties to undress cables, as appropriate.

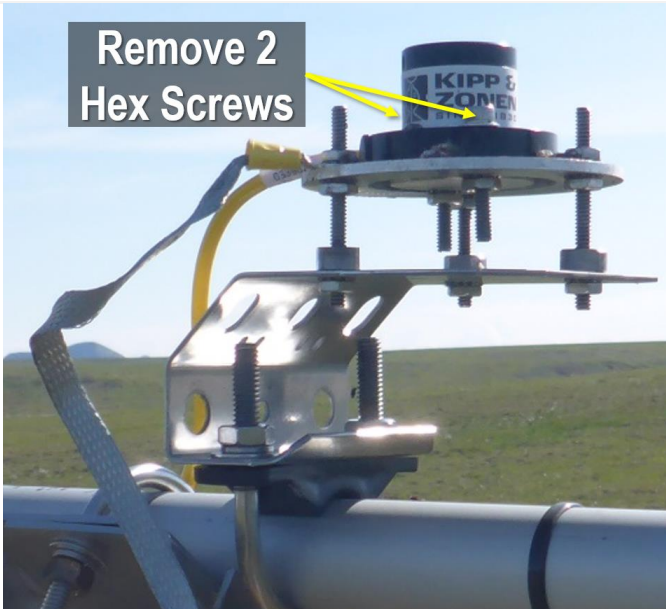


Figure 82. Remove PAR Quantum Sensor from Aquatic Met Station

**STEP 4** | Remove the PAR Quantum Sensor from the Radiation Boom arm with a hex wrench (Figure 82).



Figure 83. Remove Set Screws to Remove Net Radiometer

**STEP 5a** | Remove the Net Radiometer from the end of the Radiation Boom arm by loosening the two setscrews with a 4mm hex wrench (Figure 83). Remove this sensor with its splitter box (Figure 84).



Figure 84. Net Radiometer Splitter Box



Figure 85. Removing the Net Radiometer

**STEP 5b** | Slide off the sensor after loosening the two setscrews that adjust for roll (Figure 85). **Do not remove the sensor from the front facing setscrews that adjust for pitch.**

**[OPTIONAL]** In the event Technicians must remove the mount, unscrew the screws securing the Net Radiometer to the end of the Radiation boom via a 1" to 3/4" pipe reducer and slide it off with or without the sensor per AD [06].

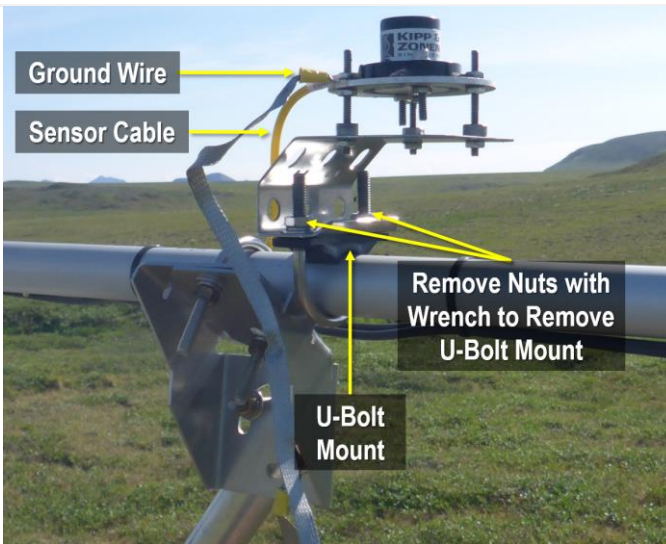


Figure 86. PAR Quantum Sensor and U-Bolt Mount Components

**STEP 4d** | **[OPTIONAL]** In the event Technicians must remove the mount, remove the ground wire that connects to the sensor leveling plate to the Aquatic Met Station infrastructure with a hex wrench and loosen the two U-bolt nuts with 1/2 inch open end box wrench to slide the entire mount from the boom arm (Figure 86).

**STEP 5** | Use the reverse order to reinstall each “refreshed” sensor. For the PAR Quatum Sensor use a compass, rotate the sensor as needed so that the cable is pointing north within  $\pm 1^\circ$ . The Net Radiometer mounts directly onto the end of the southward boom arm via a 1" to 3/4" pipe reducer. Slide the Net Radiometer and pipe reducer onto the end of the Radiation Boom.

Reference [RD \[06\]](#) and [RD \[05\]](#) for additional installation guidance and instruction.

**STEP 6** | Verify Aquatic Met Station mast and booms are level  $\pm 1^\circ$ . Reference [AD \[15\]](#), [RD \[05\]](#) and [RD \[06\]](#) for variations of these procedures and science requirements to verify the reinstallation.

**STEP 7** | Verify the installation of each sensor is level  $\pm 1^\circ$ . Reference [AD \[15\]](#), [RD \[05\]](#) and [RD \[06\]](#) for these procedures. Figure 87 and Figure 88 provide an overview of each sensor’s mount and leveling components.



For the PAR Quantum Sensor, use the bubble level on the sensor and verify with an external digital/bubble level. Loosen the 10-24 hex nuts that are on top of the leveling plate using a 5/16" socket and ratchet. Loosen or tighten the 10-24 hex nuts on underneath the level plate to level the sensor. Use the bubble level on the sensor body to indicate proper leveling. Once level, tighten the 10-24 hex nuts on top of the leveling plate to secure it in place.

For the Net Radiometer, loosen the hex setscrews on the pipe reducer using a 4mm hex wrench and use a digital level to level the sensor across the U-Axis. Tighten the hex setscrews when complete. Loosen the hex screws on the end cap of the Net Radiometer mounting body using a 4mm hex wrench. Place a digital level across the underside of one of the domes of the Net Radiometer body parallel to the boom arm and level the sensor on the V-axis. Tighten the hex screws on the end cap once complete.

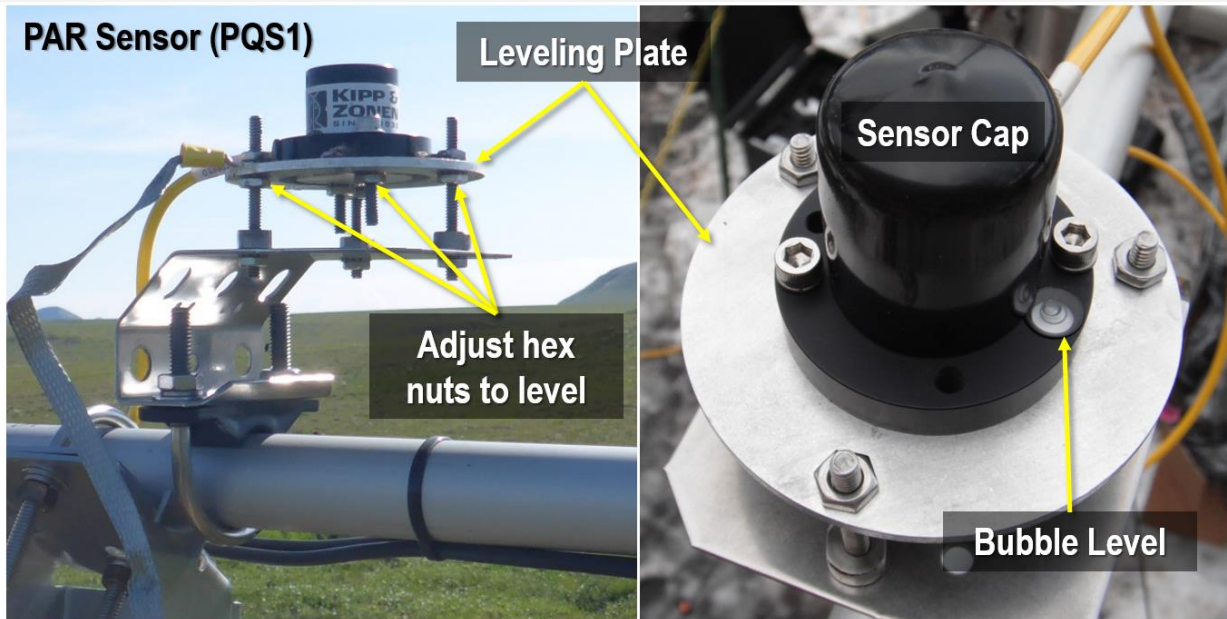


Figure 87. PAR Quantum Sensor Leveling Infographic for Aquatic Met Station (D18 OKSR on Right) (Source: [RD \[05\]](#))



**PRO TIP:** Use a telescoping/inspection mirror to check the PAR Quantum Sensor's bubble level.

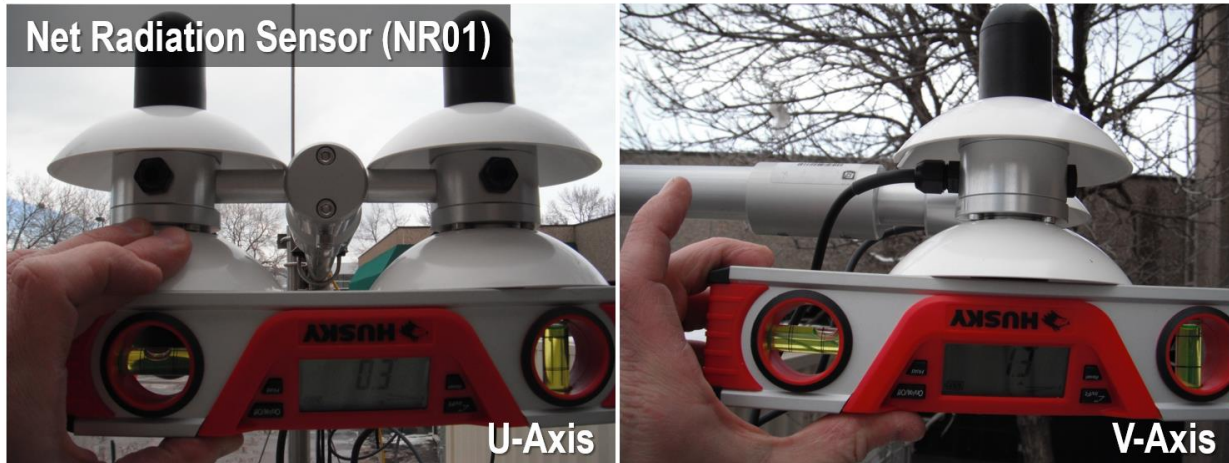


Figure 88. Net Radiometer Leveling Axes (Source: [RD \[06\]](#) and [RD \[05\]](#))

**STEP 7** | Connect sensor (12-10) and Eth-to-Comm (RJF) connections to Grape per [AD \[10\]](#). Re-dress zip ties, as appropriate. **Create slack in the cables to make drip-loops at the sensor and the Grape, with no stress on any connection. Adjust slack to make all cables agree. Do not “reverse loops” or “change direction” if possible. Never twist cables.** Remove Grape for Sensor Refresh; reference *Section 6.5 Grape Removal and Replacement Procedure on page 95*. For the Net Radiometer, two cables connect to its splitter and six cables connect to the Grape.

**STEP 8** | Restore power to the Aquatic Met Station.

**STEP 9** | Verify sensors show up in the [SAS Report](#) the next day.

#### 6.4.2 AIS Stream Radiation Sensors

A PAR Quantum Sensor resides on the top of each anchor at S-1 and S-2 to capture water surface radiation. The procedure in **Table 13** applies to both S-1 and S-2. Reference **Table 7** for equipment and materials.



Figure 89. PAR Quantum Sensor on S-1/S-2 Anchor (D18 OKSR)

**Table 13. PAR Quantum Sensors Removal and Replacement Procedure | AIS Stream Anchor (S-1/S-2).**

**STEP 1** | Power down S-1 or S-2. *Reference Appendix 8.11 – How to Power Down an AIS Device Post: Stream Combo Box.* (No need to disconnect heater ports for this procedure. Combo boxes do not have heater ports; S-1 and S-2 do not contain any heated assemblies.)



Figure 90. Downstream Sensor Set (S-2) (D18 OKSR)

**STEP 2** | PAR Quantum sensors reside on top of stream substrate-specific (sand or bedrock) anchors in various in-stream locations at AIS sites at both upstream (S-1) and downstream (S-2) locations. Wear the appropriate PPE to access the sensor in the stream (Figure 90).


 *Note: Actions at S-1 may affect S-2. Be aware and execute preventive maintenance at S-1 with caution to prevent affecting the sensor measurements at S-2.*





Figure 91. Grape (12V) High-Water Installation (D06 KING)

**STEP 3** | Disconnect Eth-to-Comm (RJF) and 10-6 sensor connection from the Merlot Grape (12V) per AD [09].

The PAR Quantum Sensor Merlot Grape (12V) may reside on the anchor with the sensor (see Figure 90) or nearby onshore if the sensor location in the stream is prone to high-water events (Figure 91). The PAR shares a Grape with the Multisonde and PRT.

Cut zip ties to undress cables, as appropriate.



Figure 92. Remove PAR Quantum Sensor from Stream Anchor (D18 OKSR)

**STEP 4** | Remove Sensor from the sand, bedrock or tripod anchor. Remove the nuts from both screws securing the PAR Quantum Sensor to the leveling plate (Figure 92).

**STEP 5** | Use the reverse order of this procedure to reinstall each “refreshed” PAR sensor at S-1/S-2.

Reference [AD \[14\]](#), [AD \[15\]](#) and [RD \[09\]](#) for additional information on these procedures.

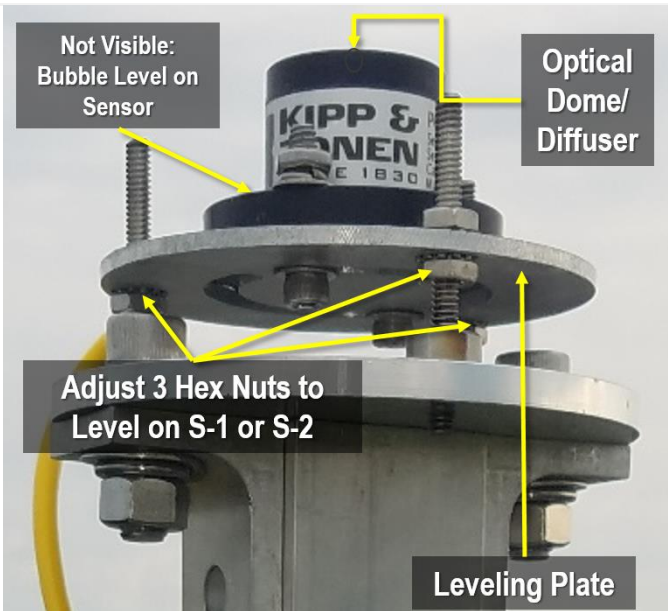


Figure 93. PAR Quantum Sensor and Primary Pyranometer Leveling Infographic

**STEP 6** | Verify the installation of each sensor at S-1 and S-2 is level  $\pm 1^\circ$ . Loosen the top 10-24 hex nuts on the plate using a 3/8 wrench. Loosen or tighten the 10-24 hex nuts underneath the plate to level the sensor. Reference the bubble level on the sensor to verify. Once level, tighten the 10-24 hex nuts on top of the leveling plate to secure it in place.

Reference [AD \[14\]](#), [AD \[15\]](#) and [RD \[09\]](#) for additional information on these procedures.

**PRO TIP:** Use a telescoping/inspection mirror to check the PAR Quantum Sensor's bubble level.



Figure 94. PAR Quantum Sensor Merlot Grape (12V)

**STEP 7** | Connect Eth-to-Comm (RJF) and sensor (12-10) connections to Grape per [AD \[10\]](#). Dress cables and cut remaining zip tie flush (Figure 94).

Remove Grape for Sensor Refresh; reference Section 6.5 Grape Removal and Replacement Procedure on page 95.

**STEP 8** | Restore power to S-1 or S-2.

**STEP 9** | Verify sensor shows up in the [SAS Report](#) the next day.

### 6.4.3 AIS Buoy Radiation Sensors

The AIS Buoy contains the Net Radiometer and PAR Quantum Sensor on the Met mast (the radiation boom arm that attaches to the Met mast). **Figure 95** displays the radiation boom in two different perspectives to view both radiation sensor installations.



Figure 95. AIS Buoy Radiation Boom: Net Radiometer and PAR Quantum Sensor

Additional information is available in [RD \[08\]](#). The two underwater PAR (uPAR) sensors are radiation sensors specific to AIS, which are also in [RD \[08\]](#), and specifically in [RD \[13\]](#). Use [RD \[25\]](#) to verify sensor reinstallation post-Sensor Refresh. Consult the Buoy PM for best practices in accessing sensors.

Table 14. Net Radiometer and PAR Quantum Sensor Removal/Replacement | AIS Buoy.



Figure 96. Unlatch to Remove Fiberglass T-Frame Covers (D09 PRPO)

**STEP 1** | Unlatch (Figure 96) and slide off the T-Frame cover where the Profiler Canister resides.

**NOTE:** The handles for the fiberglass T-Frame cover are not for lifting purposes; they guide the housing on and off the track.

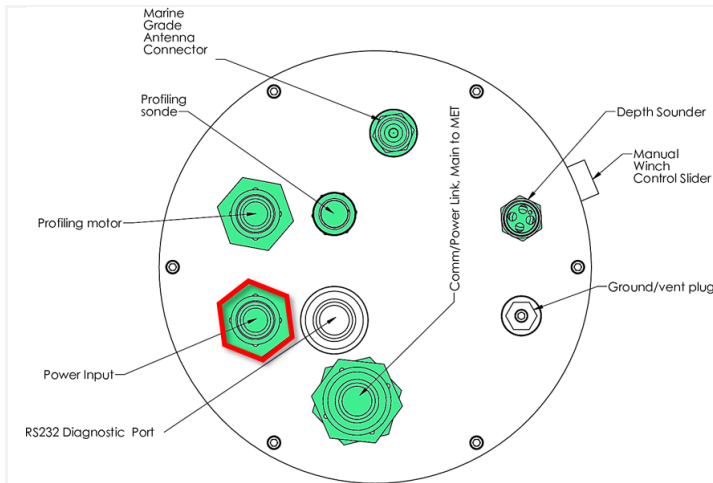


Figure 97. Profile Canister Port Mapping (Source: [AD \[10\]](#))

**STEP 2** | For annual Sensor Refresh, Power down the buoy by disconnecting the battery terminals or unplug the Power Input cord from the profiler canister. (Power Input port is in red in Figure 97.)

Reference [AD \[10\]](#) for the complete AIS Buoy Canister port mapping.

**PRO TIP:** The AIS Buoy uses Campbell Scientific data loggers instead of Grapes. Reference [RD \[08\]](#) for more information on the AIS Buoy.

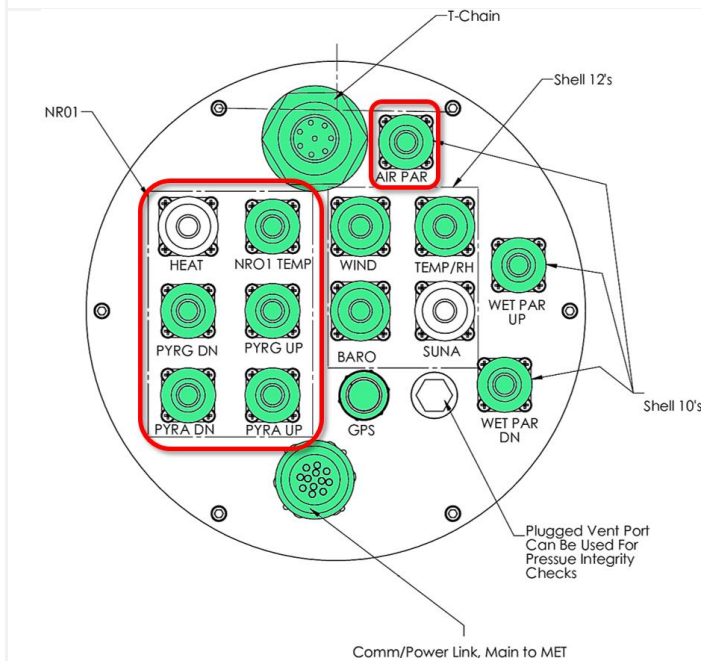


Figure 98. Met Canister Port Mapping (Source: [AD \[10\]](#))

**STEP 3** | Disconnect the radiation sensor cords from the Met Canister. Figure 98 identifies the ports for the Net Radiometer and PAR Quantum Sensors in red.

Reference [AD \[10\]](#) for the complete AIS Buoy Canister port mapping. The "AIR PAR" is the connector for the PAR Quantum Sensor on the Radiation Boom. The label aims to separate it from the uPAR sensors, which are the "WET PAR UP/DN".

**NOTE:** Grapes are not part of the AIS Buoy sensor assemblies. Power derives from an onboard DC (direct current) system (solar and battery combo) created by YSI, Inc.

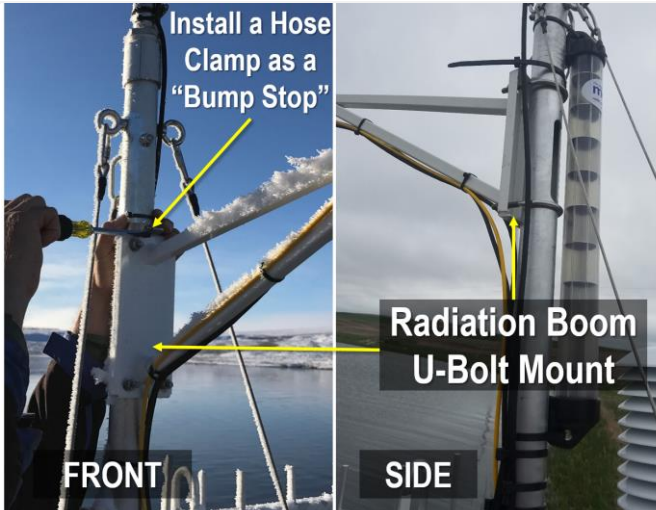


Figure 99. Radiation Boom U-Bolt Mount to Mast

**STEP 4a** | Remove the Radiation Boom arm if unable to safely remove the two radiation sensors at the end of the boom arm (Figure 99).

**PRO TIP:** Install a [hose clamp](#) above the Radiation Boom U-bolt mount to act as a bump stop to aid re-installation.



Figure 100. Radiation Sensor Winterization (D18 TOOL)

**STEP 4b** | Remove the Radiation Boom arm if the sensors are covered in ice for winterization of the AIS Buoy (Figure 100). Reference [NEON-12997 Lake Ice On-Ice Off Dates](#) for additional information.

Use hot water via thermoses to melt the ice onshore to remove each sensor assembly.<sup>5</sup> Use a bucket to catch the water. Dispose of water in staging area.

<sup>5</sup> Caleb Slemmons, *NEON-1335 UNDE ice on PAR sensors*, January 07, 2016 <https://neoninc.atlassian.net/browse/NEON-1335> and Shalane Frost, *NEON-12511 D19 BONA Ice on PAR*, January 19, 2018, <https://neoninc.atlassian.net/browse/NEON-12511>

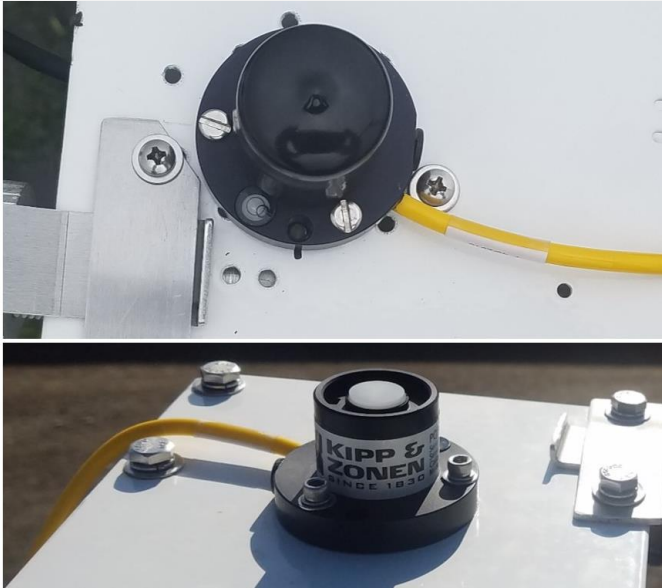


Figure 101. Remove the PAR Quantum Sensor from the Radiation Boom

**STEP 5** | Remove the PAR Quantum Sensor from the Radiation Boom arm using a flathead screwdriver or Allen key (Figure 101).

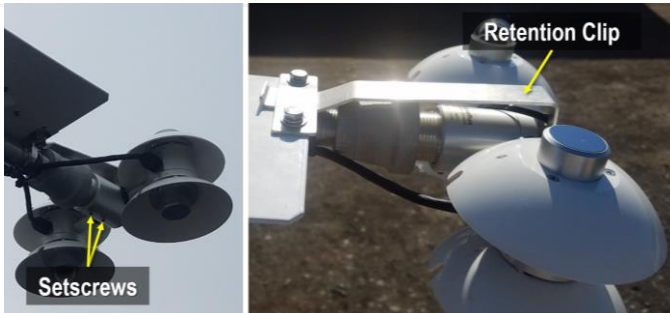


Figure 102. Remove the 2 Setscrews and Lift Retention Clip

**STEP 6a** | Remove the Net Radiometer via the two setscrews. Lift the up the aluminum retention bracket and slide the sensor from the mount (Figure 102).



Figure 103. Net Radiometer Splitter on AIS Buoy on T-Frame

**STEP 6b** | Remove the Net Radiometer splitter from under the T-Frame housing. It either is below the winch (Figure 103) or bundled with its cables below the Profiler Canister. The splitter attaches to the mount with hook and look fasteners (i.e. Velcro); it does not require any tools to remove.



Figure 104. AIS Buoy Radiation Boom Arm: Net Radiometer and PAR Quantum Sensor with Black Caps over the Sensor Diffusers

**STEP 7** | Use the reverse order to reinstall each “refreshed” sensor. Figure 104 are the two radiation sensors post-installation with their black diffuser caps to prevent dirt/oil from accumulating on the diffusers during installation. Remove the black diffusers post-installation of the “refreshed” sensor.

Reference [RD \[25\]](#) to verify the two radiation sensor installations on the AIS Buoy.

**STEP 8** | Connect sensor cables to the Met Canister (use Figure 98). Re-dress cables with zip ties and use flush cuts to cut the remaining zip tie (e.g., Figure 105). **Create slack in the cables to make drip-loops at the sensor and the Met Canister, with no stress on any connection. Adjust slack to make all cables agree. Do not “reverse loops” or “change direction” if possible. Never twist cables.**



Figure 105. Re-dress Sensor Cables with Zip Ties (D03 FLNT)

**STEP 9** | Restore power to the AIS Buoy (use Figure 97).

**STEP 10** | Verify the sensors show up in the [SAS Report](#) the next day.

### 6.5 Grape Removal and Replacement Procedure

1. Record EPROM ID/MAC Address, "Property of" Asset Tag number, Removal/Replacement date and time. The following template is an example for capturing Sensor Refresh information to update logistic records and monitor the Grape state of health via the Location Controller (LC) pre- and post-swap.

**AIS / TIS (Circle One) | Site Name:** \_\_\_\_\_

**Merlot / Concord / Catawba (Circle One) Grape | Location: S - \_\_\_ / ML - \_\_\_ / Other** \_\_\_\_\_

	Old Grape	New Grape
<b>EPROM ID/ MAC Address</b>		
<b>14-digit Asset Tag (Property of)</b>		
<b>Uninstall / Install Date and Time</b>		
<b>Moved in Maximo?</b>		

1. Employ ESD protocols when handling Grapes. Reference [RD \[04\]](#).





2. Power down the site at the TIS Tower ML, AIS Device Post or TISSP Arbor Device Post.
  - a. Reference Appendix 8.8 – How to Power Down a Tower Measurement Level (ML)
  - b. Reference Appendix 8.9 – How to Power Down an AIS Device Post: Aquatic Met Station
  - c. Reference Appendix 8.10 – How to Power Down a Soil Plot (SP) Power Box
  - d. Reference Appendix 8.11 – How to Power Down an AIS Device Post: Stream Combo Box.
  - e. Disconnect the communication box heater (12-3) ports before servicing or replacing sensors for sensor swap. (Comm box is next to the power boxes on Tower MLs or opposite side of an AIS Device Post. Disregard this step for S-1/S-2 combo boxes; these assemblies do not use heater ports.)

 **Note:** These heater ports are **NOT** interchangeable; FOPS must label each port to ensure they plug back into the correct port post-sensor swap.

3. On the Grape, disconnect the armored Ethernet cable connecting to the RJF/Eth to Comm connection.
4. Disconnect sensor connection(s).
5. Remove the Concord (24V) Grape and/or the Merlot (12V) Grape from the Grape Shield.
  - a. Remove the four screws that affix the Grape to the Grape Shield using a hex wrench.
  - b. If there is a need to remove the Grape Shield(s) from the Tower/Aquatic Met Station/Soil Plot Arbor(s), remove the Grape Shield Unistrut or pipe mount/clamp using a 3/16" hex wrench (**Figure 106**).

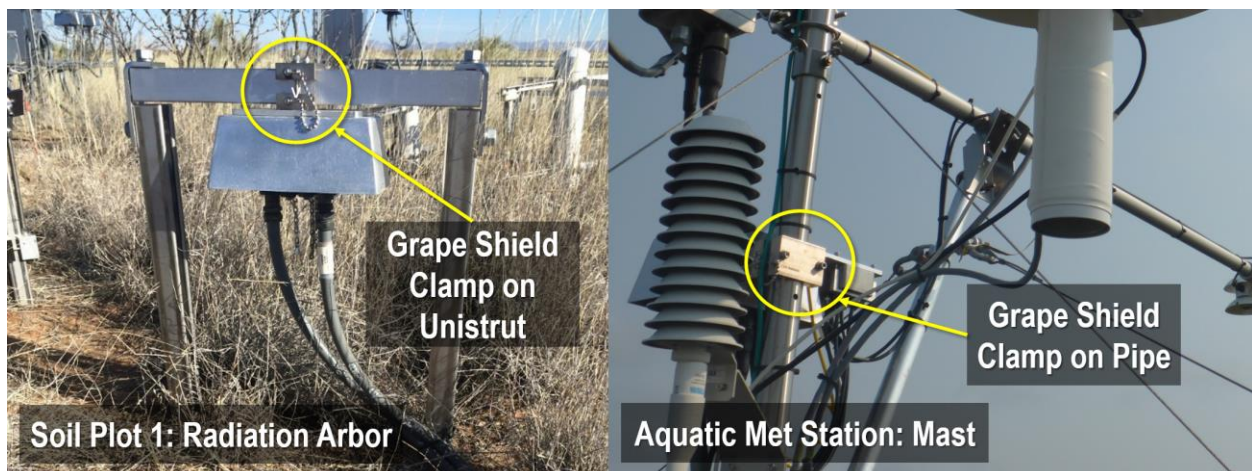


Figure 106. Grape Mount Clamps to Unistrut and Pipe Infrastructure Examples (D14 JORN/D18 TOOL).


 **PRO TIP:** It is easier to reinstall the Grape in the Grape Shield when the mount is removed from the infrastructure.

6. Install dust caps on open Amphenol connectors of old Grape.



Title: NEON Preventive Maintenance Procedure: Radiation Sensors		Date: 04/12/2022
NEON Doc. #: NEON.DOC.004429	Author: R. Zulueta, M. Cavileer, R. Willingham	Revision: C

7. Reinstall a new Grape into a Grape Shield by threading the four screws that affix the Grape to the Grape Shield using a hex wrench.
8. Remove dust caps on sensor connectors and Eth-To-Comm connector. Re-connect sensor and armored Ethernet cable in accordance with AD [09] or AD [10].
9. Re-energize site power.
  - a. Reconnect heater ports, first. Ensure they connect to the correct ports per AD [09] or AD [10]. **These port connections must be in accordance with AD [09] for TIS sites and AD [10] for AIS sites for LC Command and Control (CnC) programming.**
  - b. Apply site power from the AIS Device Post power box breakers or TIS Tower Top ML/Soil Plot power box breakers.
10. Re-energize the site and verify Grape function. Connect locally to verify function: Use the LC in the Instrument Hut at TIS sites or the Aquatics Portal PoE (Power over Ethernet) Switch with a laptop and Ethernet cable at AIS sites. Use a Terminal Emulator Program (TEP), such as PuTTY or MobaXterm, to execute the commands in Table 15.

 PuTTY Login Username: **user** | Password: **resuresu**

**Table 15. Grape Verification TEP Commands (e.g., PuTTY).**

TEP Commands	Description
<code>vd   grep 7CE0440015FD</code>	This displays the data from the grape ( <b>grep</b> ) with the MAC Address (e.g., using “7CE0440015FD”). Enter either in decimal or hexadecimal format. Use “ <b>grep -i</b> ” to ignore case.
<code>vd -s [sensor eeprom id]</code>	To view data from a sensor. For example “root@D23-HQW-LC1:~#vd -s 3171982”
<code>vd -s [sensor eeprom id] -r [stream number]</code>	To view data from a sensor and specific data stream.

## 6.6 Cleaning & Packaging of Returned Sensor

Field Operations staff clean, package, and ship the sensors back to the CVAL at the NEON project HQ (Battelle Ecology) for annual sensor swap/calibration requirements. For this procedure, the items requiring CVAL calibration are in **Table 8**. Reference **Table 7** for the equipment, tools and consumables necessary for conducting the NEON HQ, CVAL Sensor Refresh procedures. Asset tags must accompany each sensor returning to CVAL and reflect CFGLOC changes in NEON’s project Asset Management and Logistic Tracking System.

**Table 16. Radiation Sensor Packaging Requirements.**

<b>STEP 1</b>   Conduct decontamination on each sensor in accordance with <a href="#">AD [05]</a> .
---



**STEP 2** | Package dry sensors post-decontamination. Ship sensors in containers (e.g., pelican cases or similar) with pertinent protective hardware (e.g., caps/ESD bags/bubble wrap). Secure any moving parts and loose cables that may incur damage or damage contents. If Domains are missing shipping containers or protective hardware, submit an issue ticket to request additional supplies from CVAL (e.g., [NEON-11712](#)). Below is a visual summary of the Radiation Sensors that have additional packing requirements.



Figure 107. Primary Pyranometer

Primary Pyranometer<sup>6</sup> | Figure 107

This sensor requires ESD protocols. Cap the cables. It is OK if the sensor cable does not have a cap, if shipping/handling using ESD protocols and packaging. **Do not stack sensors on top of this sensor when packing; the dome may incur damage.** CVAL recommends using ESD bubble wrap bags to pad the sensor for packaging.


 *Note: [Primary Pyranometer Infographic](#): use to reference specific information, as necessary. However, TIScience maintenance procedures in Chapter 5 supersede where information may conflict.*



Figure 108. Primary Pyranometer Screen Requires Cleaning

Primary Pyranometer Sensor (**CMP22**) | Figure 108

Decontamination of this sensor should address the cleaning of the screen; however, in the event it does not, please ensure this screen is clean before shipping to CVAL for Sensor Refresh.

<sup>6</sup> Doug Kath, *NEON-13301 CMP22, asset tag 3000000016573, serial number 160420 was returned to HQ's without its cables (splitter box) or ventilator.* March 12, 2018. <https://neoninc.atlassian.net/browse/NEON-13301>



Figure 109. Sunshine Pyranometer

### Sunshine Pyranometer | Figure 109

This sensor requires ESD protocols. Cap the cable. It is OK if the sensor cable does not have a cap, if shipping/handling using ESD protocols and packaging.

Do not stack sensors on top of this sensor when packing; the dome may incur damage. CVAL recommends using ESD bubble wrap bags to pad the sensor for packaging.



Figure 110. Biological Temperature Sensor Assemblies

### Biological Temperature Sensor | Figure 110 and Figure 111



Figure 111. Decontaminate Shield

This sensor requires ESD protocols. Use a green cap to protect the sensor end and cap the cable. It is OK if the sensor cable does not have a cap, if shipping/handling using ESD protocols and packaging.



Figure 112. Incorrect Way to Package Sensors for Sensor Refresh

Biological Temperature Sensor | Figure 112

Do not return the Biological Temperature Sensor to CVAL using the black caps. Send using the green caps with each component identified in Figure 110 and Figure 114.

Biological Temperature Sensor (SI-111) | Figure 113

This sensor comes with a strain relief cord connector (component is visible in Figure 111 and Figure 113) to prevent strain on its power/data cable. This connector may not exist for some assemblies or eventually degrade/no longer function as strain relief. If that is the case, use zip ties to secure the cable to the sensor's sun shield (see Figure 113 for an example using zip ties). Cut off excess zip tie with flush cutters.



Figure 113. Biological Temperature Sensor Requires Cable Strain Relief – Use Zip Ties to Prevent Straining the Cable if the Sensor has No Connector



Figure 114. Biological Temperature Sensor must have these Components Post-Decontamination

Biological Temperature Sensor (SI-111)  
| Figure 114

Post decontamination, the sensor must have the components in Figure 114 and a green protective cap.

**PRO TIP:** Note/document wear and damage, including corrosion, stress cracks, frayed cables, loose cable clamps, cable tightness, etc. to determine if sensor inspection frequencies require adjustment. (This is applicable to each Radiation Sensor.)



Figure 115. PAR Quantum Sensor with Black Cap over Diffuser

PAR Quantum Sensor (PQS1) | Figure 115

This sensor requires ESD protocols. Cap the sensor diffuser and cable. It is OK if the sensor cable does not have a cap if shipping/handling using ESD protocols and packaging.



Figure 116. Net Radiometer with Black Caps over the sensors.

Net Radiometer (NR01) | Figure 116 and Figure 117



Figure 117. Cap Cables

This sensor requires ESD protocols. Cap the four sensor diffusers and all cables.



Figure 118. Soil Quantum Line Sensor (QLS)

Quantum Line Sensor | Figure 118

Employ ESD protocols. If a black cone screw on attachment is found with the sensor, please remove and return to CVAL.

**Note:** If any of the Radiation Sensors are defective, submit a trouble ticket and affix a red tag with the trouble ticket number on it. See Section 7 for additional guidance).

Please conduct decontamination (see AD [05]) on the sensors/subsystems returning to NEON HQ.


For the cleaning and packaging of Grapes and Sensors post-removal, conduct the following steps:

1. Check mounting holes for spiders and spider webs. Remove biologics and carefully clean connectors with a lint-free cloth.
2. Cap cables/connectors, as applicable, on each device. Cap all Amphenol connectors on the Grape.
3. Conduct decontamination on the exterior per AD [05]. Remove any additional biologics from the devices.
4. Place each device in an ESD bag and shipping container.



Title: NEON Preventive Maintenance Procedure: Radiation Sensors		Date: 04/12/2022
NEON Doc. #: NEON.DOC.004429	Author: R. Zulueta, M. Cavileer, R. Willingham	Revision: C

- Update asset records via the NEON’s project Asset Management and Logistic Tracking System (e.g., MAXIMO). NEON HQ, Logistics Warehouse (LOGWAR) receives the Grapes and Sensors for refresh and distributes to CVAL.

 **Note: In general, to minimize errors for CI, all devices leaving a CFGLOC must move to SITE first, then TRANSIT/DxxSUPPORT.**

- Provide an electronic packing list to CVAL with the Box number and Asset Tag number (14-digit Property Tag ID (“Property of”) number) of each item. CVAL uses this information to verify items via LOGWAR/general HQ distribution of shipments.
- Prepare a Bill of Lading.

 **Note: For any Non-CVAL initiated sensor returns, please notify CVAL of the return.**

Package sensor items via original packaging, as requested or outlined via the Issue Management System and return to the NEON project HQ using the following address:

**BATTELLE ECOLOGY, ATTN: CVAL  
1685 38TH STREET, SUITE 100  
BOULDER, CO 80301**

**Only include sensors/subsystems for refresh.** Additional equipment must ship separately as they may require attention from other NEON HQ departments. Sensor refresh shipments go direct to CVAL. If sensors are shipping to HQ to address a trouble ticket, per guidance via the Issue Management System, return to the NEON project HQ using the following address:

**BATTELLE ECOLOGY, ATTN: REPAIR LAB  
1685 38TH STREET, SUITE 100  
BOULDER, CO 80301**

## 6.7 Sensor Refresh Record Management of Assets

In addition to the physical movement of devices, the sensor refresh process requires dedicated and accurate record management of asset movement and location.

### 6.7.1 NEON Asset Management and Logistic Tracking System Requirements

Technicians must update the instrumentation records via the NEON’s project Asset Management and Logistic Tracking System (MAXIMO). NEON HQ must maintain accurate record keeping on the location, date, and time offline of an instrument to ensure NEON HQ, Computer Infrastructure, Data Products, and CVAL are aware to apply the correct algorithms, calibrations, and processing factors. Ensure the CFG





**neon**  
Operated by Battelle

<i>Title:</i> NEON Preventive Maintenance Procedure: Radiation Sensors		<i>Date:</i> 04/12/2022
<i>NEON Doc. #:</i> NEON.DOC.004429	<i>Author:</i> R. Zulueta, M. Cavileer, R. Willingham	<i>Revision:</i> C

location reflects the current site of the sensor. All devices leaving a CFGLOC must move to SITE first, then TRANSIT/DxxSUPPORT.



Title: NEON Preventive Maintenance Procedure: Radiation Sensors		Date: 04/12/2022
NEON Doc. #: NEON.DOC.004429	Author: R. Zulueta, M. Cavileer, R. Willingham	Revision: C

## 7 ISSUE REPORTING OUTPUTS

FOPS must report issues encountered while conducting preventive maintenance in the NEON project Issue Management/Reporting System. To ensure a quick response and remedy to an issue, please include as much information and detail, as possible. This includes, but is not limited, to the following:

- Domain and Site name
- Date and Time
- Technician Full Name
- Issue Narrative (detailed narrative of the issue, specific location of issue on tower infrastructure, relevant 2<sup>nd</sup>/3<sup>rd</sup> order effects to infrastructure, possible cause [e.g., weather event, obstruction, human activity])
- Multiple Photographs (to capture vantage points/perspectives for remote diagnostic)
- Provide Part Number/Manufacturer Information, EPROM ID, Asset Tags, IP Address, MAC Address, etc.
- Provide Diagnostic Information (from firmware, if applicable), such as error codes, values, etc. Provide screenshots.

**Table 17. Metadata Output Checklist.**

Issue Reporting Datasheet		
Datasheet field		Entry
NEON Site Code		
Maintenance Date		
Maintenance Technician		
Preventive Maintenance	Issue Noted	Issue Summary
Cables & Connectors - Condition Check	<input type="checkbox"/>	
Sensor - Condition Check	<input type="checkbox"/>	
Sensor - Configuration Check	<input type="checkbox"/>	
Sensor – Clean	<input type="checkbox"/>	
Sensor - Other Specific Checks	<input type="checkbox"/>	
Environmental Information	<input type="checkbox"/>	
<b>Notes</b>		

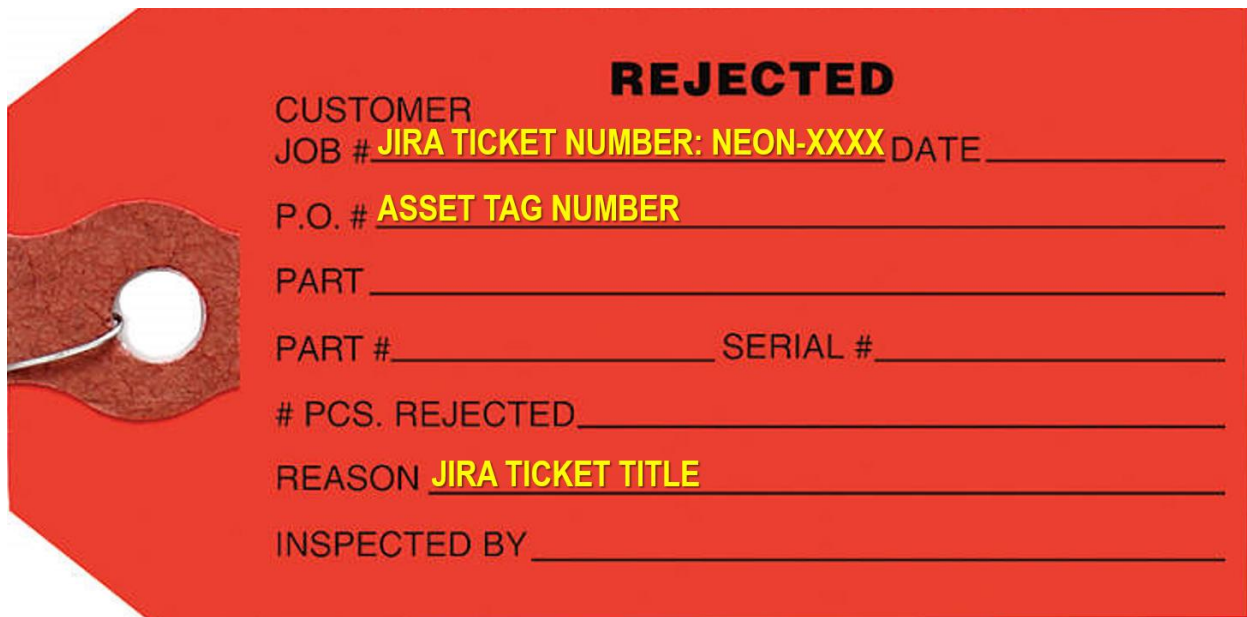


Title: NEON Preventive Maintenance Procedure: Radiation Sensors		Date: 04/12/2022
NEON Doc. #: NEON.DOC.004429	Author: R. Zulueta, M. Cavileer, R. Willingham	Revision: C

**For Barometric Pressure Sensor corrective actions, ensure proper tracking of the asset via the NEON issue management and tracking system (e.g., JIRA) to establish a chain of custody of the asset between Engineering Repair Laboratory and CVAL.**

Conduct the following tasks to ensure the proper management of the asset between sites:

1. For each issue where NEON, HQ is replacing a defective instrument/subsystem at a TIS site, please create a sub-task in the NEON Issue Management and Reporting System for the defective asset from the reported issue. Resolution of an issue does not occur with the installation of a replacement, but with the root cause analysis of the issue deriving from the defective asset. FOPS may resolve the ticket upon installation of the replacement if a sub-task exists for the defective asset for NEON HQ to conduct root cause analysis<sup>7</sup>.
2. Ship all defective equipment/assets with a red "Rejected" tag. **Figure 119** displays the minimum information requirements for each tag.



**Figure 119. Red Rejected Tag for Defective Assets (MX104219).**

<sup>7</sup> JIRA-5848 is a good example for reference.



## 8 APPENDIX

- 8.1 List of all NEON TIS Sites
- 8.2 List of All NEON AIS Sites
- 8.3 TIS Core Tower Sites
- 8.4 AIS Met Station Sites
- 8.5 AIS Lake Buoy Sites
- 8.6 Heated and Extreme-Heated TIS Site List
- 8.7 Heated and Extreme-Heated AIS Site List
- 8.8 How to Power Down a Tower Measurement Level (ML)
- 8.9 How to Power Down an AIS Device Post: Aquatic Met Station
- 8.10 How to Power Down a Soil Plot (SP) Power Box
- 8.11 How to Power Down an AIS Device Post: Stream Combo Box



## 8.1 List of all NEON TIS Sites

**Table 18. List of all NEON TIS sites including Domain, Site ID, Name, and Site Type.**

Domain	Site ID	Site Name	Site Type
01	BART	Bartlett Experimental Forest	Gradient
01	HARV	Harvard Forest	Core
02	BLAN	Blandy Experimental Farm	Gradient
02	SERC	Smithsonian Environmental Research Center	Gradient
02	SCBI	Smithsonian Conservation Biology Institute	Core
03	OSBS	Ordway-Swisher Biological Station	Core
03	DSNY	Disney Wilderness Preserve	Gradient
03	JERC	Jones Ecological Research Center	Gradient
04	LAJA	Lajas Experimental Station	Gradient
04	GUAN	Guanica Forest	Core
05	TREE	Treehaven	Gradient
05	UNDE	UNDERC	Core
05	STEI	Steigerwaldt Land Services	Gradient
06	KONA	Konza Prairie Biological Station - Gradient	Gradient
06	KONZ	Konza Prairie Biological Station	Core
06	UKFS	The University of Kansas Field Station	Gradient
07	ORNL	Oak Ridge	Core
07	MLBS	Mountain Lake Biological Station	Gradient
07	GRSM	Great Smoky Mountains National Park, Twin Creeks	Gradient
08	LENO	Lenoir Landing	Gradient
08	TALL	Talladega National Forest	Core
08	DELA	Dead Lake	Gradient
09	WOOD	Woodworth	Core
09	NOGP	Northern Great Plains Research Laboratory	Gradient
09	DCFS	Dakota Coteau Field School	Gradient
10	CPER	Central Plains Experimental Range	Core
10	STER	North Sterling, CO	Gradient
10	RMNP	Rocky Mountain National Park, CASTNET	Gradient
11	CLBJ	LBJ National Grassland	Core
11	OAES	Klemme Range Research Station	Gradient
12	YELL	Yellowstone Northern Range (Frog Rock)	Core
13	NIWO	Niwot Ridge Mountain Research Station	Core
13	MOAB	Moab	Gradient
14	SRER	Santa Rita Experimental Range	Core
14	JORN	Jornada LTER	Gradient
15	ONAQ	Onaqui-Ault	Core



Domain	Site ID	Site Name	Site Type
16	WREF	Wind River Experimental Forest	Core
16	ABBY	Abby Road	Gradient
17	TEAK	Lower Teakettle	Gradient
17	SOAP	Soaproot Saddle	Gradient
17	SJER	San Joaquin Experimental Range	Core
18	TOOL	Toolik	Core
18	BARR	Barrow Environmental Observatory	Gradient
19	BONA	Caribou Creek - Poker Flats Watershed	Core
19	DEJU	Delta Junction	Gradient
19	HEAL	Healy	Gradient
20	PUUM	Pu'u Maka'ala Natural Area Reserve	Core



## 8.2 List of All NEON AIS Sites

**Table 19. List of all NEON AIS sites including Domain, Site ID, Name, and Site Type.**

Domain #	Site ID	Site Name	Site Type
01	HOPB	Lower Hop Brook	Core
02	LEWI	Lewis Run	Gradient
02	POSE	Posey Creek	Core
03	FLNT	Flint River	Gradient
03	SUGG	Ordway-Swisher Biological Station - Suggs Lake	Core
03	BARC	Ordway-Swisher Biological Station - Barco Lake	Core
04	GUIL	Rio Guilarte	Gradient
04	CUPE	Rio Cupeyes	Core
05	LIRO	Little Rock Lake	Gradient
05	CRAM	Crampton Lake	Core
06	MCDI	McDiffett Creek	Gradient
06	KING	Kings Creek	Core
07	WALK	Walker Branch	Core
07	LECO	LeConte Creek	Gradient
08	MAYF	Mayfield Creek	Core
08	TOMB	Lower Tombigbee River at Choctaw Refuge	Gradient
08	BLWA	Black Warrior River near Dead Lake	Gradient
09	PRPO	Prairie Pothole	Core
09	PRLA	Prairie Lake at Dakota Coteau Field School	Gradient
10	ARIK	Arikaree River	Core
11	BLUE	Blue River	Gradient
11	PRIN	Pringle Creek	Core
12	BLDE	Blacktail Deer Creek	Core
13	WLOU	West St Louis Creek	Gradient
13	COMO	Como Creek	Core
14	SYCA	Sycamore Creek	Core
15	REDB	Red Butte Creek	Core
16	MART	Martha Creek	Core
16	MCRA	McRae Creek	Gradient
17	TECR	Teakettle 2 Creek	Core
17	BIGC	Upper Big Creek	Gradient
18	TOOK	Toolik Lake	Gradient
18	OKSR	Oksrukuyik Creek	Core
19	CARI	Caribou Creek at Poker Flats	Core



Title: NEON Preventive Maintenance Procedure: Radiation Sensors		Date: 04/12/2022
NEON Doc. #: NEON.DOC.004429	Author: R. Zulueta, M. Cavileer, R. Willingham	Revision: C

### 8.3 TIS Core Tower Sites

**Table 20. List of TIS Core Tower Sites.**

Domain	Site ID	Site Name
1	HARV	Harvard Forest
2	SCBI	Smithsonian Conservation Biology Institute
3	OSBS	Ordway-Swisher Biological Station
4	GUAN	Guanica Forest
5	UNDE	UNDERC
6	KONZ	Konza Prairie Biological Station
7	ORNL	Oak Ridge
8	TALL	Talladega National Forest
9	WOOD	Woodworth
10	CPER	Central Plains Experimental Range
11	CLBJ	LBJ National Grassland
12	YELL	Yellowstone Northern Range (Frog Rock)
13	NIWO	Niwot Ridge Mountain Research Station
14	SRER	Santa Rita Experimental Range
15	ONAQ	Onaqui-Ault
16	WREF	Wind River Experimental Forest
17	SJER	San Joaquin Experimental Range
18	TOOL	Toolik
19	BONA	Caribou Creek - Poker Flats Watershed
20	PUUM	Pu'u Maka'ala Natural Area Reserve





## 8.4 AIS Met Station Sites

**Table 21. List of AIS Met Station Sites.**

Domain	Site ID	Site Name	Core/Gradient
1	HOPB	Lower Hop Brook	Core
2	LEWI	Lewis Run	Gradient
2	POSE	Posey Creek	Core
3	BARC	Ordway-Swisher Biological Station - Barco Lake	Core
3	FLNT	Flint River	Gradient
3	SUGG	Ordway-Swisher Biological Station - Suggs Lake	Core
4	CUPE	Rio Cupeyes	Core
4	GUIL	Rio Guilarte	Gradient
5	CRAM	Crampton Lake	Core
5	LIRO	Little Rock Lake	Gradient
6	KING	Kings Creek	Core
6	MCDI	McDiffett	Gradient
7	LECO	LeConte Creek	Gradient
7	WALK	Walker Branch	Core
8	MAYF	Mayfield Creek	Core
9	PRLA	Prairie Lake at Dakota Coteau Field School	Gradient
9	PRPO	Prairie Pothole	Core
10	ARIK	Arikaree River	Core
11	BLUE	Blue River	Gradient
11	PRIN	Pringle Creek	Core
12	BLDE	Northern Rockies	Core
13	COMO	Como Creek	Core
13	WLOU	West St Louis Creek	Gradient
14	SYCA	Sycamore Creek	Core
15	REDB	Red Butte Creek	Core
16	MART	Martha Creek	Core
16	MCRA	McRae Creek	Gradient
17	BIGC	Upper Big Creek	Gradient
17	TECR	Teakettle 2 Creek	Core
18	OKSR	Oksrukuyik Creek	Core
18	TOOK	Toolik Lake	Gradient
19	CARI	Caribou Creek at Poker Flats	Core



## 8.5 AIS Lake Buoy Sites

**Table 22. List of AIS Lake Buoy Sites.**

Domain	Site ID	Site Name	Core/Gradient
3	BARC	Ordway-Swisher Biological Station - Barco Lake	Core
3	FLNT	Flint River	Gradient
3	SUGG	Ordway-Swisher Biological Station - Suggs Lake	Core
5	CRAM	Crampton Lake	Core
5	LIRO	Little Rock Lake	Gradient
8	BLWA	Black Warrior River near Dead Lake	Core
8	TOMB	Lower Tombigbee River at Choctaw Refuge	Gradient
9	PRLA	Prairie Lake at Dakota Coteau Field School	Gradient
9	PRPO	Prairie Pothole	Core
18	TOOK	Toolik Lake	Gradient



## 8.6 Heated and Extreme-Heated TIS Site List

**Table 23. List of TIS Heated and Extreme-Heated Sites.**

Domain	Site ID	Site Name	Core/Gradient	Heated/Extreme
1	HARV	Harvard Forest	Core	Heated
1	BART	Bartlett Experimental Forest	Gradient	Heated
2	SCBI	Smithsonian Conservation Biology Institute	Core	Heated
2	SERC	Smithsonian Environmental Research Center	Gradient	Heated
2	BLAN	Blandy Experimental Farm	Gradient	Heated
5	UNDE	UNDERC	Core	Heated
5	STEI	Steigerwaldt Land Services	Gradient	Heated
5	TREE	Treehaven	Gradient	Heated
6	KONZ	Konza Prairie Biological Station	Core	Heated
6	UKFS	The University of Kansas Field Station	Gradient	Heated
6	KONA	Konza Prairie Biological Station	Gradient	Heated
7	ORNL	Oak Ridge	Core	Heated
7	MLBS	Mountain Lake Biological Station	Gradient	Heated
7	GRSM	Great Smoky Mountains National Park, Twin Creeks	Gradient	Heated
9	WOOD	Woodworth	Core	Heated
9	DCFS	Dakota Coteau Field School	Gradient	Heated
9	NOGP	Northern Great Plains Research Laboratory	Gradient	Heated
10	CPER	Central Plains Experimental Range	Core	Heated
10	STER	North Sterling, CO	Gradient	Heated
10	RMNP	Rocky Mountain National Park, CASTNET	Gradient	Heated
11	CLBJ	LBJ National Grassland	Core	Heated
11	OAES	Klemme Range Research Station	Gradient	Heated
12	YELL	Yellowstone Northern Range (Frog Rock)	Core	Heated
13	NIWO	Niwot Ridge Mountain Research Station	Core	Extreme
13	MOAB	Moab	Gradient	Heated
15	ONAQ	Onaqui-Ault	Core	Heated
16	WREF	Wind River Experimental Forest	Core	Heated
16	ABBY	Abby Road	Gradient	Heated
17	SJER	San Joaquin	Core	Heated
17	SOAP	Soaproot Saddle	Gradient	Heated
17	TEAK	Lower Teakettle	Gradient	Heated
18	TOOL	Toolik Lake	Core	Extreme
18	BARR	Barrow Environmental Observatory	Gradient	Extreme
19	BONA	Caribou Creek - Poker Flats Watershed	Core	Extreme
19	DEJU	Delta Junction	Gradient	Extreme
19	HEAL	Healy (Eight Mile)	Gradient	Extreme



## 8.7 Heated and Extreme-Heated AIS Site List

**Table 24. List AIS Heated and Extreme-Heated Sites.**

Domain	Site ID	Site Name	Core/Gradient	Heated/Extreme
1	HOPB	Hop Brook	Core	Heated
2	POSE	Posey Creek	Core	Heated
2	LEWI	Lewis Run	Gradient	Heated
5	CRAM	Crampton Lake	Core	Heated
5	LIRO	Little Rock Lake	Gradient	Heated
6	KING	Kings Creek	Core	Heated
6	MCDI	McDiffit Creek	Gradient	Heated
7	WALK	Walker Branch	Core	Heated
7	LECO	LeConte Creek	Gradient	Heated
9	PRPO	Prairie Pothole	Core	Heated
9	PRLA	Prairie Lake at Dakota Coteau Field School	Gradient	Heated
10	ARIK	Arikaree River	Core	Heated
11	PRIN	Pringle Creek	Core	Heated
11	BLUE	Blue River	Gradient	Heated
12	BLDE	Blacktail Deer Creek	Core	Heated
13	COMO	Como Creek	Core	Heated
13	WLOU	West St. Louis Creek	Gradient	Heated
15	REDB	Red Butte Creek	Core	Heated
16	MART	Martha Creek	Core	Heated
16	MCRA	McRae Creek	Gradient	Heated
17	TECR	Teakettle 2	Core	Heated
17	BIGC	Upper Big Creek	Gradient	Heated
18	OKSR	Oksrukuyik Creek	Core	Heated
18	TOOK	Toolik Lake	Gradient	Extreme Heated
19	CARI	Caribou Creek at Poker Flats	Core	Extreme Heated



## 8.8 How to Power Down a Tower Measurement Level (ML)

Power down the Measurement Level (ML) power box via the adjacent Communications (Comm) box providing power to tower ML.

 *Note: When working on power systems, use tools with insulated handles.*

### HOW TO POWER DOWN A TOWER MEASUREMENT LEVEL (ML)

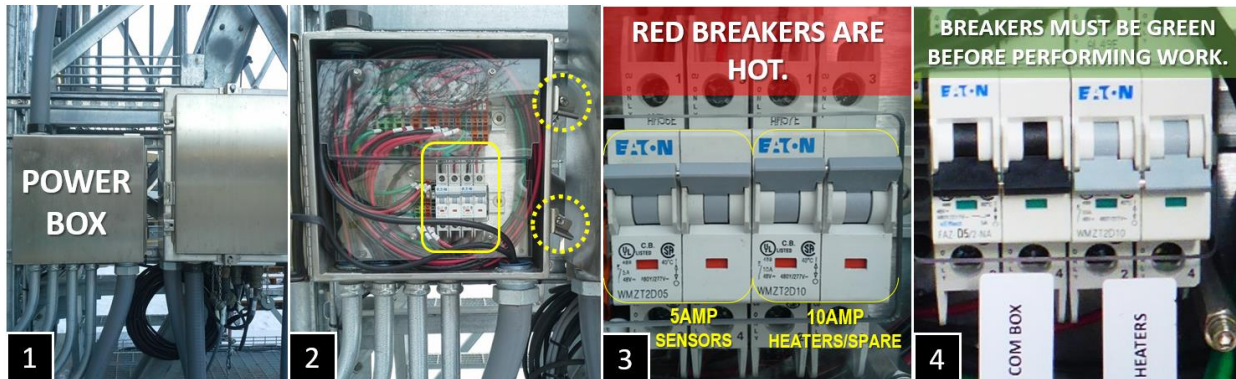


Figure 120. How to Power Down a Tower ML.

To power down a Tower ML to conduct preventive maintenance and/or to swap sensors and subsystems, conduct the following steps in accordance with **Figure 120**.

1. Locate the ML power box.
  - a. **Connections may reside on multiple levels if ports are unavailable. Please ensure this procedure occurs for all applicable power boxes for the ML. For example, short towers combine ML 1 and 2 for power and communications; therefore, the sensors on ML1 connect to the Comm and power box on ML2.**
2. Open the power box using a Phillips-head screwdriver on the two clasps on the right. **Figure 120** identifies the location of the two clasps and the location of the breakers in image number 2.
3. Locate the breakers. A 5 Amp breaker is on the left and A 10 Amp breaker is on the right.
  - a. The 5 Amp breaker turns the power on/off to the sensors (via their Comm box).
  - b. The 10 Amp breaker turns the power on/off for sites employing heaters. If a site does not employ a heater, then it is a spare breaker.
  - c. **Red breakers indicate the power is ON – live voltage.**
4. Flip the breakers down on the 5 Amp and the 10 Amp breakers to de-energize the ML.
  - a. The color on the breaker is green, signifying the power is OFF.



Title: NEON Preventive Maintenance Procedure: Radiation Sensors		Date: 04/12/2022
NEON Doc. #: NEON.DOC.004429	Author: R. Zulueta, M. Cavileer, R. Willingham	Revision: C

- a. Conduct LOTO procedures (required for FOPS personnel on equipment over 50V).
5. **FOR HEATED SITES ONLY:** After disabling power from the Power Box, disconnect all Comm Box heater ports before servicing or replacing sensors for Sensor Refresh. *Use AD [09] to verify heater ports onsite where Comm Boxes are combined.* Heater ports are the 12-3 connectors on the Comm box.

 **Note:** *These heater ports are not interchangeable; FOPS must label each port to ensure they plug back into the correct port post-sensor swap. Heater port locations are critical for LC CnC Software to operate properly*

6. Proceed with the Preventive Maintenance, Sensor Refresh and/or Corrective Maintenance.

### 8.9 How to Power Down an AIS Device Post: Aquatic Met Station

Powering down the site enables Technicians to perform work with fewer hazards to themselves and to the equipment. It also mitigates requiring NEON Headquarters to conduct data quality analysis when Technicians are onsite close enough to the sensors to influence data collection. This procedure shuts down power at the Aquatic Met Station and the Groundwater Wells (GWW) data transmission, if the Grape and Base Radio for the GWWs connects to the Aquatic Met Station Comm box. This procedure allows Technicians to conduct work on the sensors on the infrastructure in the Aquatic Met Station. This does not shut down power at the GWWs. A DC system provides power to the GWW Aqua TROLL and remote radio. *Reference [AD \[11\]](#) for additional information.*

2. Power down the site from the AIS Device Post power box via the breakers. Use **Figure 121** for this procedure.
  - a. Open the Power Box using a Philips head screwdriver.
  - b. Flip both breakers from RED to GREEN: 5 Amp Breakers for Sensors and 10 Amp Breakers for Heaters. Disregard the 10 Amp Breakers if they are spares/no-heaters present onsite.
  - c. Conduct LOTO procedures (required for FOPS personnel on equipment over 50V).

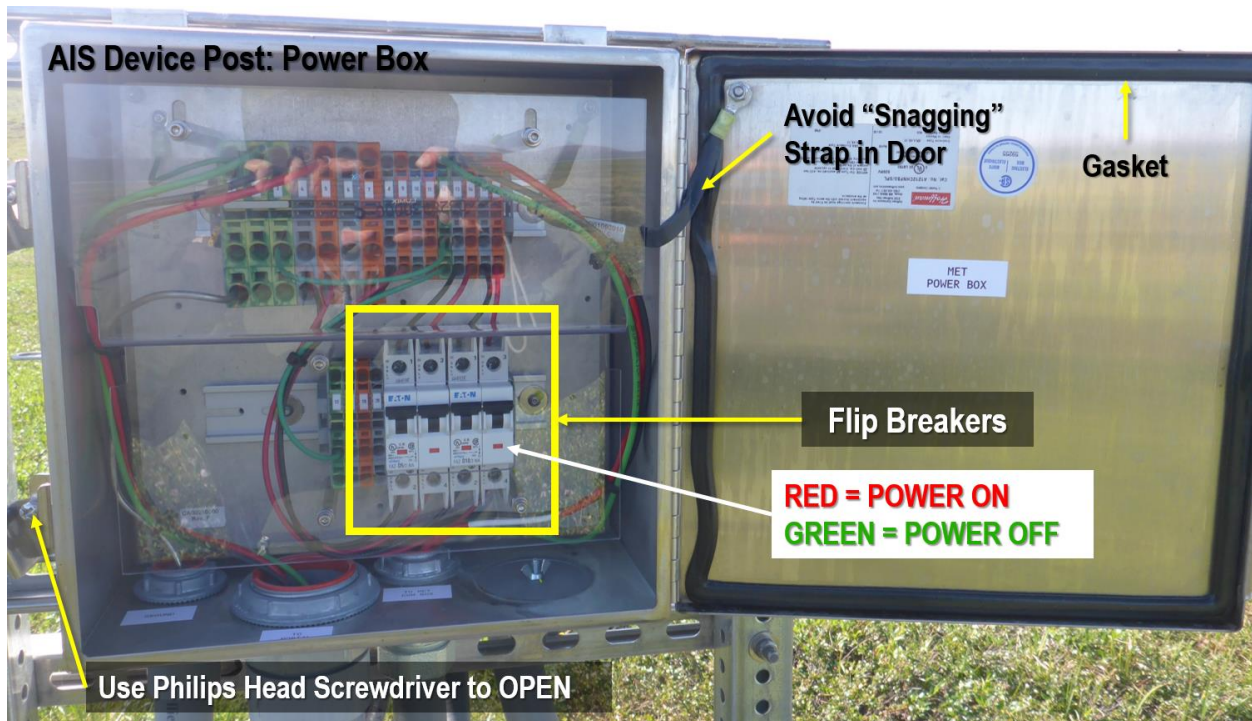


Figure 121. AIS Device Post: Power Box Components (Domain 18 OKSR AIS Aquatic Met Station).

3. **FOR HEATED SITES ONLY:** After disabling power from the Power Box, disconnect all Comm Box heater ports before servicing or replacing sensors for Sensor Refresh. Use [AD \[10\]](#) to verify heater ports onsite where Comm Boxes are grouped together (i.e., sites that have the Secondary Precipitation share a Comm Box with the Aquatic Met Station). Heater ports are the 12-3 connectors on the Comm box.
  - a. The **Aquatic Met Station Comm Box** provides power to the Aspirated Air Temperature Shield (AATS) and 2D Wind heaters. The 2D wind heater port is in front of the AATS heater port in [Figure 122](#) per [AD \[10\]](#). (**PRO TIP:** The AATS cable is larger in diameter than the 2D wind cable. The 2D Wind heater transformer mounts directly to the AIS Device Post, which allows Technicians to visually verify the cable connection and port).

**Note:** These heater ports are not interchangeable; FOPS must label each port to ensure they plug back into the correct port post-sensor swap. **Heater port locations are critical for LC CnC Software to operate properly!**

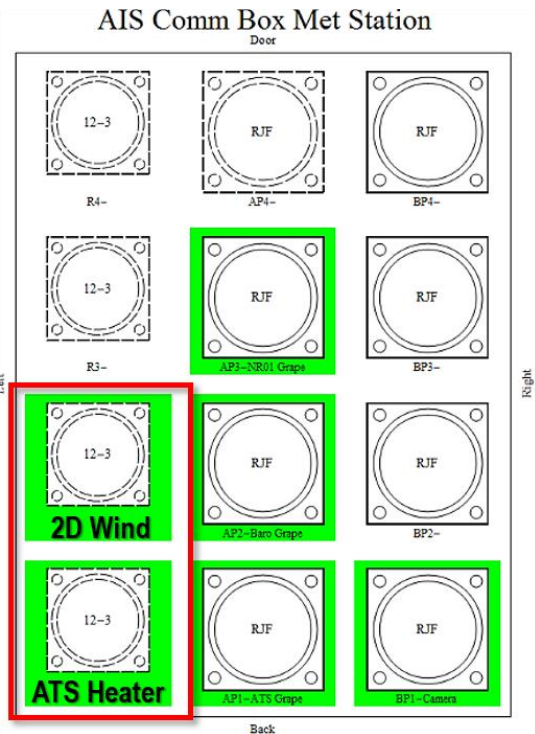
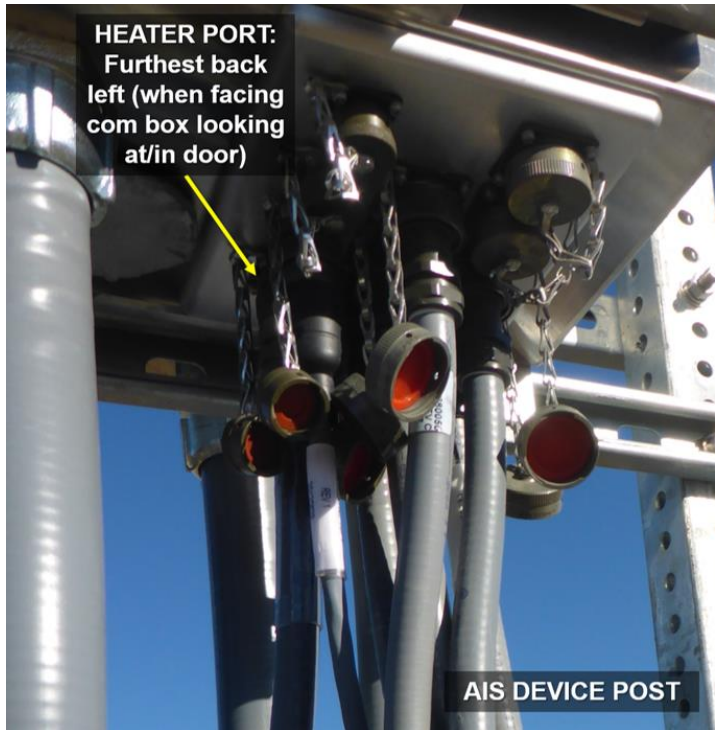


Figure 122. AIS Device Post: Comm Box Heater Ports for Aspirated Temperature Shield (ATS) and 2D Wind (Source: AD [10]).

**PRO TIP:** How to tell the difference between Heater ports and Grape ports are, as follows: Heater ports consist of four 12-3 ports total onsite and use 3-pin connectors (Figure 122). Inside the Comm box at a TIS or AIS site, wires run directly to the ports (hardwired in the Comm box). Comm ports consist of seven or eight ports and have RJF/Ethernet connectors. Inside the Com box at TIS or AIS site, Ethernet pass-thru connectors, typically with white 1-ft Ethernet jumper cables, connect to the PoE Switch.

If there is a need to remove a sole sensor assembly onsite, then power down the sensor assembly from its Grape. Remove the armored Ethernet cable from the Merlot or Concord Grape RJF/Eth-To-Comm connector before disconnecting or connecting sensor connections. Removing sensor connections without removing the RJF/Eth-To-Comm cable is best practice to avoid accidental hot swapping when the power is ON. Reference AD [10] for Aquatic Met Station Grape mapping. Follow ESD procedures in RD [04].

### 8.10 Howto Power Down a Soil Plot (SP) Power Box

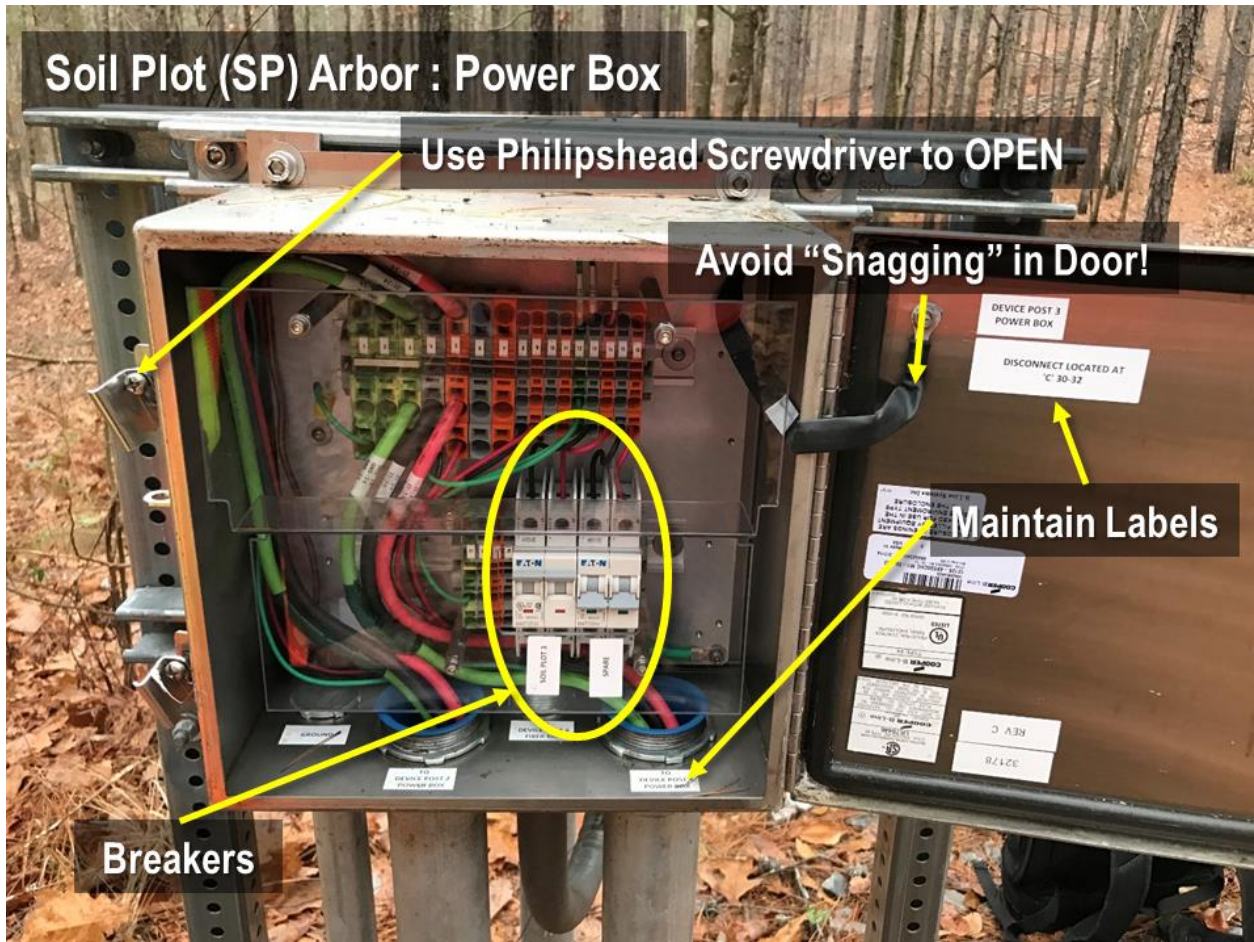
Powering down the soil plot enables Technicians to perform work with fewer hazards to them selves and to the equipment. It also mitigates requiring NEON Headquarters to conduct data quality analysis when Technicians are onsite close enough to the sensors to influence data collection.

1. Power down the plot from the Soil Plot Device Post Power Box.





- a. Open the Power Box using a Philips head screwdriver (**Figure 123**).



**Figure 123. Open Soil Plot Device Post Power Box.**

- b. Flip both breakers from RED to GREEN to de-energize the sensors (**Figure 124**).

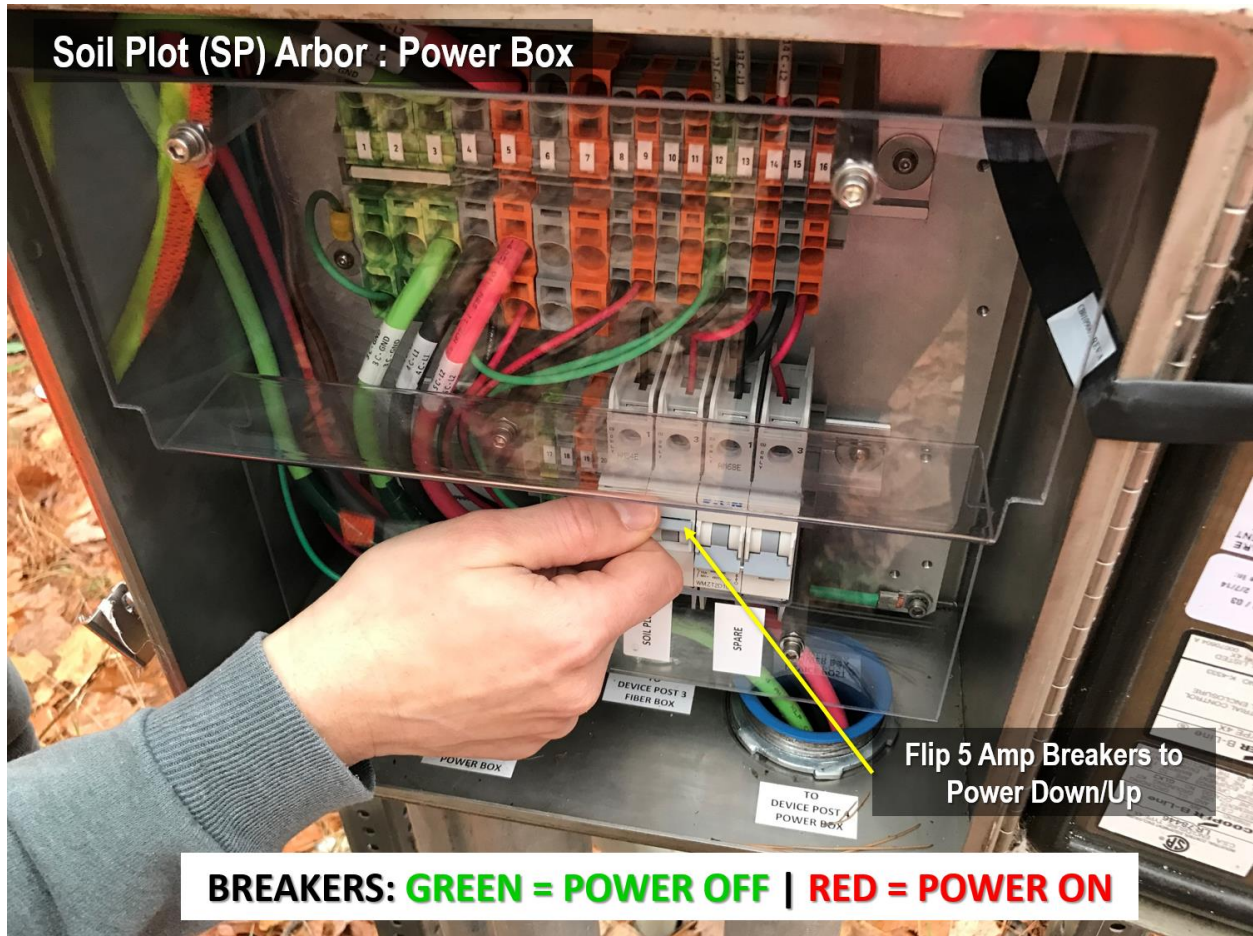


Figure 124. Soil Plot Device Post: Flip 5 Amp Breakers<sup>8</sup> (Location: D08TALL).

- c. Conduct LOTO procedures and proceed with the Preventive Maintenance, Sensor Refresh and/or Corrective Maintenance.

If there is a need to remove a sole sensor assembly onsite, then power down the sensor assembly from its Grape. Remove the Ethernet cable from the Merlot Grape RJF/Eth-To-Comm connector before disconnecting or connecting sensor connections.

### 8.11 How to Power Down an AIS Device Post: Stream Combo Box

Powering down the site enables Technicians to perform work with fewer hazards to themselves and to the equipment. It also eliminates the need for NEON HQ to conduct data quality analysis when

<sup>8</sup> Hand model: Genevieve Faria



Technicians are onsite close enough to the sensors to influence data collection. *Reference AD [11] for additional information.*

1. Power down the site from the AIS Device Post power box via the breakers. Use **Figure 125** for this procedure.
  - a. Open the Power Box using a flat head screwdriver.
  - b. Flip both breakers from RED to GREEN: 5 Amp Breakers for Sensors and 10 Amp Breakers for Heaters. Disregard the 10 Amp Breakers if they are spares/no-heaters present onsite.
  - c. Conduct LOTO procedures (required for FOPS personnel on equipment over 50V).

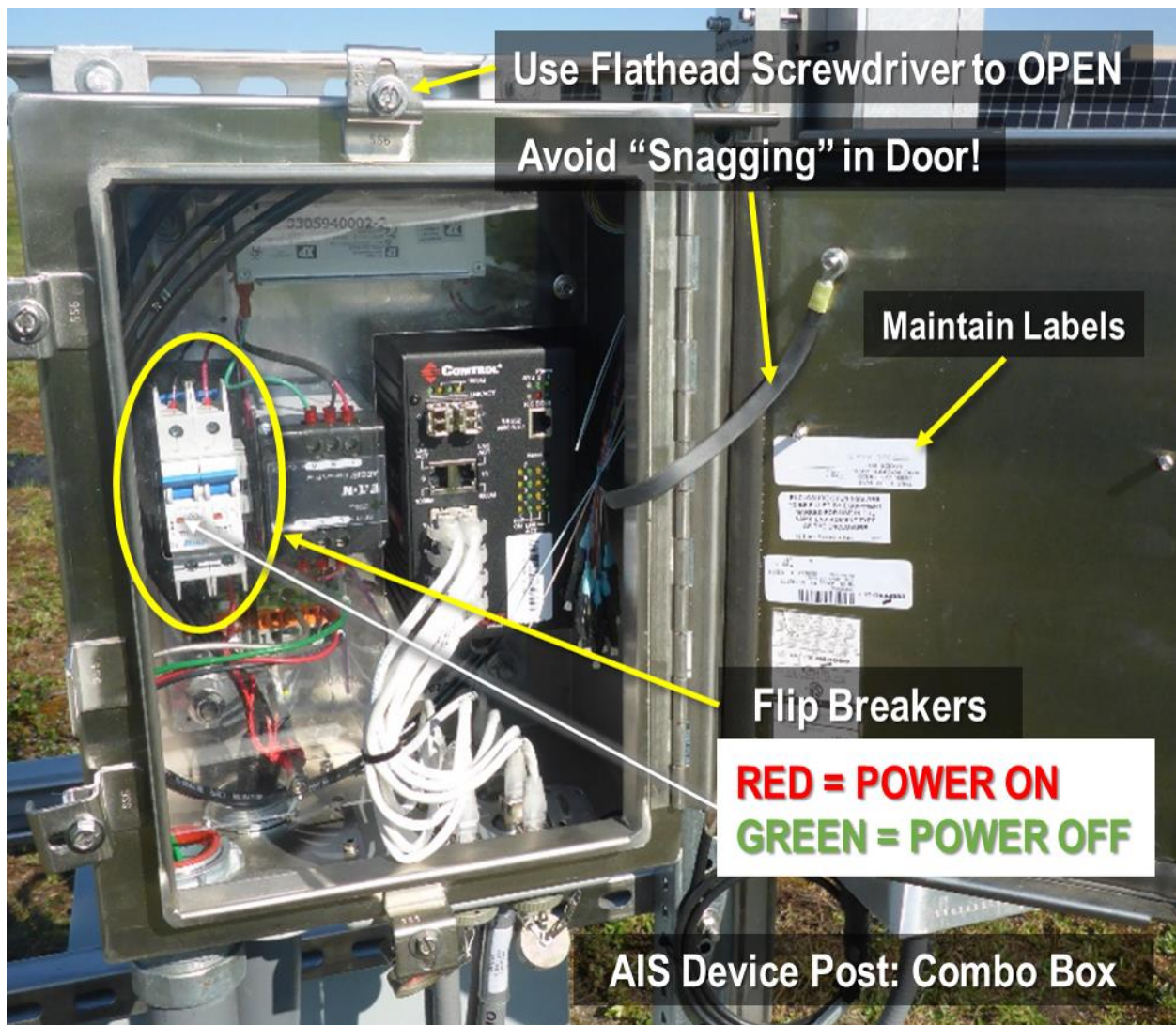


Figure 125. AIS Device Post: Combo Box Power Components (Domain 18 OKSR AIS S1/S2).



<i>Title:</i> NEON Preventive Maintenance Procedure: Radiation Sensors		<i>Date:</i> 04/12/2022
<i>NEON Doc. #:</i> NEON.DOC.004429	<i>Author:</i> R. Zulueta, M. Cavileer, R. Willingham	<i>Revision:</i> C

2. The stream sensor's combo box does not use heater ports. Proceed with preventive maintenance/corrective action activities.



<i>Title:</i> NEON Preventive Maintenance Procedure: Radiation Sensors		<i>Date:</i> 04/12/2022
<i>NEON Doc. #:</i> NEON.DOC.004429	<i>Author:</i> R. Zulueta, M. Cavileer, R. Willingham	<i>Revision:</i> C

## 9 SOURCES

Cain, Gregory. Soil Plot Verification Checklist, V 1.0. May 22, 2017.

Ellis, Clay. TIS Post-Deployment and I&V Impact Report D06R2 KONA Tower 11-18-2015. November 18, 2015. Accessed via Agile March 22, 2018.

Mahon, Daniel. TIS Post-Deployment and I&V Impact Report D08 TALL Tower - 03-27-2015. March 27, 2015. Accessed via Agile March 22, 2018.

Roberts, Brendan. TIS Post-Deployment and I&V Impact Report D19R3 HEAL Tower 12-21-2015. December 21, 2015. Accessed via Agile March 22, 2018.

Webster, Joe. TIS Post Deployment and I&V Impact Report D08R2 DELA Tower - 12.12.14. December 21, 2015. Accessed via Agile March 22, 2018.

Hand Models: Geoff Simonds, Madeline Cavileer, Genevieve Faria