



<i>Title:</i> NEON Preventive Maintenance Procedure: AIS Buoy		<i>Date:</i> 03/08/2022
<i>NEON Doc. #:</i> NEON.DOC.004613	<i>Author:</i> M. Cavileer, G. Simonds, R. Willingham	<i>Revision:</i> C

NEON PREVENTIVE MAINTENANCE PROCEDURE: AIS BUOY

PREPARED BY	ORGANIZATION	DATE
Geoff Simonds	SE	08/07/2017
Rachael Willingham	SE	08/07/2017
Madeline Cavileer	ENG	02/23/2018

APPROVALS	ORGANIZATION	APPROVAL DATE
Kate Thibault	SCI	03/08/2022

RELEASED BY	ORGANIZATION	RELEASE DATE
Tanisha Waters	CM	03/08/2022

See configuration management system for approval history.



Title: NEON Preventive Maintenance Procedure: AIS Buoy		Date: 03/08/2022
NEON Doc. #: NEON.DOC.004613	Author: M. Cavileer, G. Simonds, R. Willingham	Revision: C

Change Record

REVISION	DATE	ECO #	DESCRIPTION OF CHANGE
A	08/07/2017	ECO-04988	Initial release.
B	04/06/2018	ECO-05496	Incorporation of Buoys at River sites (D03 and D08); changing terminology from AIS Lake Buoys to AIS Buoys for inclusion on Buoys at both Lake and River sites; updated Winterization procedures from lessons learned from D18 TOOK Winterization and CVAL receiving sensors from FOPs; expanded on Section 2 Applicable, Reference Documents and External Resources and Section 3; made corrections and/or clarifications on areas of reported confusion relating to Chapter 6 Sensor Refresh and Winterization procedures; added updated graphics or improved procedures with a new graphic from a recent installations; made grammar and formatting edits, where possible. Incorporated AIS Buoy flipping countermeasures in Section 3 and Section 5.
C	03/08/2022	ECO-06786	<ul style="list-style-type: none">Revised logo, minor formatting corrections



Title: NEON Preventive Maintenance Procedure: AIS Buoy		Date: 03/08/2022
NEON Doc. #: NEON.DOC.004613	Author: M. Cavileer, G. Simonds, R. Willingham	Revision: C

TABLE OF CONTENTS

1 DESCRIPTION..... 1

1.1 Purpose..... 1

1.2 Scope..... 1

2 RELATED DOCUMENTS AND ACRONYMS..... 2

2.1 Applicable Documents..... 2

2.2 Reference Documents..... 2

2.3 External References..... 3

2.4 Acronyms..... 4

2.5 Terminology..... 5

3 SAFETY AND TRAINING 6

4 SENSOR OVERVIEW (SENSORS ONLY)..... 8

4.1 Description..... 8

4.1.1 Domain 03 Flint River (FLNT) AIS Buoy..... 9

4.2 Sensor Specific Handling Precautions.....10

4.2.1 Multisonde Handling Precautions.....10

4.2.2 PAR Handling Precautions.....10

4.2.3 Buoy Electronics.....11

4.3 Operation.....11

5 INSPECTION AND PREVENTIVE MAINTENANCE13

5.1 Equipment.....13

5.2 Subsystem Location and Access.....14

5.3 Maintenance Procedure.....15

5.3.1 Remote Monitoring.....17

5.3.2 AIS Buoy Infrastructure Inspection.....17

5.3.3 Winch Assembly Maintenance.....28

5.3.4 D03 FLNT ONLY: Peristaltic Pump Maintenance.....29

5.3.5 Adjusting the Mooring System.....30

5.3.6 Seasonal Removal/Towing, Storage and Redeployment.....31

6 REMOVAL AND REPLACEMENT (SUBSYSTEM ONLY).....49



Title: NEON Preventive Maintenance Procedure: AIS Buoy		Date: 03/08/2022
NEON Doc. #: NEON.DOC.004613	Author: M. Cavileer, G. Simonds, R. Willingham	Revision: C

6.1 Equipment49

6.2 Removal and Replacement Procedure.....49

 6.2.1 Profiler Multisonde Removal and Replacement51

 6.2.2 D03 FLNT ONLY: Pump Profiler Multisonde Removal and Replacement.....56

 6.2.3 SUNA and uPAR Removal and Replacement for Dual PAR SUNA Mount.....57

 6.2.4 uPAR Removal and Replacement for Retractable uPAR Mounting System64

 6.2.5 D03 FLINT ONLY: Multisonde and SUNA Sensor Removal and Replacement for Fixed Underwater Tube Mounts.....67

 6.2.6 Profiler and MET Canister Removal and Replacement.....71

6.3 Cleaning & Packaging of Returned Sensor.....74

6.4 Sensor Refresh Record Management of Assets.....79

 6.4.1 NEON Asset Management and Logistic Tracking System Requirements80

 6.4.2 Remote Connection Program Information Requirements.....80

7 ISSUE REPORTING OUTPUTS81

 7.1 Preventive Maintenance Documentation.....81

8 APPENDIX A: CHECKING FOR HUMIDITY IN THE PROFILE/MET CANISTERS83

9 APPENDIX B: AIS BUOY INSTRUMENT OPERATING/STORAGE TEMPERATURES.....84

10 APPENDIX C: CONNECTING TO THE SUNA ON THE BUOY85

11 APPENDIX D: SETTING THE SUNA INTERNAL CLOCK93

12 DOMAIN 03 FLNT: FLINT RIVER PREDICTION RESOURCES FOR MAINTENANCE AND/OR ANTICIPATE POTENTIAL FLOODS/DROUGHTS94

 12.1 Flood Prediction Resources for D03 FLNT.....96

13 SOURCES.....97

LIST OF TABLES AND FIGURES

Table 1. AIS Buoy Preventive Maintenance Equipment List.....13

Table 2. AIS Buoy Preventive Maintenance Frequency Summary.....15

Table 3. YSI Profiler Port Mapping for Profiler Canister Decoded.....21

Table 4. YSI Met Station Port Mapping for MET Canister Decoded.....22

Table 5. AIS Buoy Instrumentation Calibration and Validation Requirements Summary49

Table 6. AIS Buoy SUNA & uPAR Removal/Reinstallation Procedure for Dual PAR SUNA Mount60

Table 7. AIS Buoy uPAR Removal/Reinstallation Procedure for Retractable PAR Mounting System.....65



Title: NEON Preventive Maintenance Procedure: AIS Buoy		Date: 03/08/2022
NEON Doc. #: NEON.DOC.004613	Author: M. Cavileer, G. Simonds, R. Willingham	Revision: C

Table 8. AIS Buoy Multisonde & SUNA Removal/Reinstallation Procedure for D03 FLNT Fixed Tube

Mounts67

Table 9. AIS Buoy Sensor Packaging Requirements.....75

Table 10: AIS Buoy Metadata Output Checklist.....81

Table 11. AIS Buoy Equipment Environmental Parameters*84

Table 12. Stage Crest Data.....94

Table 13. Exceedance probability table for stream discharge at USGS Station #02353000, Flint River at Newton. Green rows highlight exceedance probability values associated with a stage level of >33.00 feet.....95

Figure 1. Tether Domain Boat to AIS Buoy Deck Cleats - Two Tie-offs for Lakes/One Tie-off for Rivers 6

Figure 2. Domain Boat Tethered to AIS Buoy (D03 FLNT)..... 7

Figure 3. Dual PAR SUNA Mount Bracket - Scissor Risk Safety Note! 7

Figure 4. AIS Buoy Sensor Components and Infrastructure 8

Figure 5. D03 FLNT River Buoy Mechanical Drawing (Source: YSI Integrated Systems & Services).....10

Figure 6. AIS Buoy Operational Overview with Power Distribution System (PDS) and Data Acquisition System (DAS)11

Figure 7. AIS Buoy for Domain 09 Prairie Pothole (PRPO) Lake15

Figure 8. AIS Buoy for Domain 03 Flint River (FLNT).....15

Figure 9. Attachment Points for Floating Deck & Pontoon.....17

Figure 10. Mooring Bridle Attachment to AIS Buoy17

Figure 11. Shackles at the Anchor End of Bridle with Line Floats.....18

Figure 12. Bridle Attachment Points Example (What to Expect in the Water)18

Figure 13. Exposed Wood Debris in AIS Buoy Mooring Lines (D03 FLNT).....19

Figure 14. T-Frame: GPS, Beacon and Antenna19

Figure 15. Profiler Canister Port Mapping (Source: AD [13])21

Figure 16. MET Canister Port Mapping22

Figure 17. AIS Buoy Battery Box/Enclosure and Battery (Where to Connect DMM)23

Figure 18. Bump Stop on Met Mast24

Figure 19. SUNA Radio Antenna and Radar Reflector on Met Mast.....24

Figure 20. Guy-wire Components25

Figure 21. Looking Down on the Dual PAR SUNA Mount and Guy-wires26

Figure 22. Depth Sounder Bracket (Left) and Depth Sounder Instrument (Right) on Floating Deck.....26

Figure 23. T-Chain and T-Chain Mount on Floating Deck26

Figure 24. D03 FLNT ONLY: T-Chain Location, Mount and Weight.....27

Figure 25. Winch Assembly Components.....28

Figure 26. Properly Greased Winch Axle (Axle Rod).....28

Figure 27. D03 FLNT: Peristaltic Pump Schematic (Source: YSI) & Enclosure Components29

Figure 28. D03 FLNT: Pump Tubing pulled from the River30

Figure 29. Mounting the AIS Buoy on the Trailer.....32



Title: NEON Preventive Maintenance Procedure: AIS Buoy		Date: 03/08/2022
NEON Doc. #: NEON.DOC.004613	Author: M. Cavileer, G. Simonds, R. Willingham	Revision: C

Figure 30. Tie-off Points for Servicing the AIS Buoy for Lakes (Use Only 1 Tie-off Point for River Sites) ...33

Figure 31. Protect Winch Cable from Water33

Figure 32. Dual PAR SUNA Mount in an Upright Position with Guy-wires for Transport.....34

Figure 33. D03 FLNT ONLY: Four Slide Locks to Flatten Retractable PAR Mounting System for Transportation35

Figure 34. D03 FLNT ONLY: Retractable PAR Mounting System Flat on Deck for Transport35

Figure 35. Remove Cotter Pin and Shackle Connecting Bridles to Line Float/Anchor Line36

Figure 36. DO NOT USE CLEATS.....37

Figure 37. Recommended Towing Technique37

Figure 38. Disconnect the Batteries to Remove from the Battery Enclosure.....38

Figure 39. Radiation Boom Mount U-bolt Location.....39

Figure 40. Remove Instruments from Met Mast40

Figure 41. RM Young Wind Monitor (2D Wind) Upper and Lower Collar on Met Mast41

Figure 42. Dual SUNA PAR Mount E-Clip.....42

Figure 43. Removing the AIS Buoy from Toolik Lake (TOOL) in D18 for Winterization42

Figure 44. Ratchet Straps secure the AIS Buoy to the Trailer.....43

Figure 45. Carmanah M650H Beacon with IR Remote (Source ER [02]).....47

Figure 46. T-Chain Sensor – Temperature Probe.....48

Figure 47. RS-232 Diagnostic Port on Profile Canister (Lower Canister) in Green.....52

Figure 48. Flag 2 (High).....52

Figure 49. Magnetic Switch to Activate the Winch53

Figure 50. Disconnect Multisonde from the Lake Buoy Winch.....53

Figure 51. How to Replace Multisonde Internal D-Cell Batteries and Grease O-Rings (Source: ER [16])...54

Figure 52. Multisonde Probe Tool and Krytox GPL 205 Lubricant Use (Source: ER [16]).....54

Figure 53. Thread the Winch Cable Properly to Return Multisonde to Water55

Figure 54. Pump Profiler Canister | Power Input Cable Location in Red with Star Symbol.....56

Figure 55. Use Wrench to Remove the Multisonde from the Two Clamps.....57

Figure 56. Remove Multisonde from Flow Cell57

Figure 57. Buoy Dual PAR/SUNA Winch.....59

Figure 58. Dual PAR SUNA Mount Lifting Guidance59

Figure 59. Profile Canister Port Mapping (Source: AD [13]).....60

Figure 60. Raise the Dual PAR/SUNA Mount on the AIS Buoy.....60

Figure 61. Remove SUNA from Dual PAR SUNA Mount Cage Clamps (Source: YSI Mechanical Engineer, Allen Hunter)61

Figure 62. Reinstall SUNA from Dual PAR SUNA Mount Cage Clamps (Source: YSI Mechanical Engineer, Allen Hunter)61

Figure 63. Use Screwdriver or Nut Driver to Remove uPAR Sensor from Mount.....62

Figure 64. Replace with "New" Sensor62

Figure 65. Secure Sensor in Mount63

Figure 66. Align uPAR Sensor and Cable63



Title: NEON Preventive Maintenance Procedure: AIS Buoy		Date: 03/08/2022
NEON Doc. #: NEON.DOC.004613	Author: M. Cavileer, G. Simonds, R. Willingham	Revision: C

Figure 67. Underwater Eyebolts for Dual PAR SUNA Mount.....64

Figure 68. Retractable PAR Mounting System | FLNT River Buoy (Source: YSI Integrated Systems & Services).....65

Figure 69. Pump Profiler Canister Port Mapping (Source: AD [13]).....65

Figure 70. Release Two Slide Locks to Bring Extension Bar uPAR Mount Above Water.....66

Figure 71. uPAR Mount Winch66

Figure 72. Lock Slide Locks to Secure Sensors Above Water.....66

Figure 73. Fixed Submerged Sensors on D03 FLNT AIS Buoy: Multisonde & SUNA Tube Mounts67

Figure 74. Pump Profiler Canister Port Mapping (Source: AD [13]).....67

Figure 75. Multisonde & SUNA Tube Mount Caps with Stainless Steel Knobs68

Figure 76. Remove Four Stainless Steel Knobs to Remove Tube68

Figure 77. Lift Cap to Access Sensor in Tube.....68

Figure 78. Remove Fixed Sensor Tube from Water.....69

Figure 79. Fixed Sensor Tube Collecting Debris from River69

Figure 80. Align Cable with Notch where Cap/Lid mates with bottom Flange.....69

Figure 81. SUNA Fixed Tube.....70

Figure 82. SUNA Wiper Placement.....70

Figure 83. T-Frame/Cover Exterior and Interior Components.....71

Figure 84. Do not disconnect the “Comm Power Link Main to Met” Connector on the Met Canister72

Figure 85. PVC Canister Enclosures for MET and Winch or Pump Profiler72

Figure 86. AIS Buoy Pitch and Roll Diagram.....73

Figure 87. Click "Num Display" Icon73

Figure 88. Collect Heading, Pitch and Roll for Offsets74

Figure 89. SUNA in a Pelican Case.....75

Figure 90. Multisonde Probes/Sensors75

Figure 91. RM Young Wind Vane Propeller Parts/Equipment for Removal76

Figure 92. How to Remove the Propeller from the RM Young Wind Vane76

Figure 93. Vaisala HMP-155 Sensor with Yellow Protective Cap76

Figure 94. Vaisala HMP-155 Sensor with Yellow Protective Cap & Radiation Shield Mounting Component – Do Not Send to CVAL77

Figure 95. Vaisala Barometric Pressure Sensor - Requires ESD Packaging.....77

Figure 96. PQS1/PAR Sensor with Black Cap over Diffuser – Req. ESD77

Figure 97. uPAR Sensor with Black Cap over Diffuser – Req. ESD78

Figure 98. NR01 with Black Caps over Diffuser – Req. ESD.....78

Figure 99. Cap Cables78

Figure 100. T-Chain with Waterproof Plug Post-Decontamination.....78

Figure 101. MET Canister and Profiler Canister (NOTE: DISREGARD GREEN GROUND WIRE – KEEP GROUND WIRE AT DOMAIN)79

Figure 102. Red Rejected Tag for Defective Assets (MX104219)82

Figure 103. Click Num Display to Load the Configuration Files83



<i>Title:</i> NEON Preventive Maintenance Procedure: AIS Buoy		<i>Date:</i> 03/08/2022
<i>NEON Doc. #:</i> NEON.DOC.004613	<i>Author:</i> M. Cavileer, G. Simonds, R. Willingham	<i>Revision:</i> C

Figure 104. SUNA Instrument and Power Connections on the AIS Buoy.....86

Figure 105. "Connect" Icon.....86

Figure 106. Select the "Connect" Icon (Connection Mode: Disconnected).....87

Figure 107. SUNA Baud Rate for AIS Buoy and In-Stream (S-2)87

Figure 108. Connection to SUNA is in Transition88

Figure 109. Successfully Connected to the SUNA88

Figure 110. Select "Sensor>Advanced>Command Terminal" from Dropdown89

Figure 111. Command Terminal Window "get -- cfg"89

Figure 112. Verify SUNA Configuration Settings are Correct using the C3.....90

Figure 113. Change "tempcomp [value]" to "tempcomp off" Example90

Figure 114. "tempcomp off" Changes Confirmed.....91

Figure 115. Click "Disconnect" Icon.....91

Figure 116. Click "Disconnect" to Properly Disconnect from the SUNA92

Figure 117. Safe to Unplug Cable from SUNA92

Figure 118. Select "Sensor" and "Set Clock"93

Figure 119. Click "Sync Time" to Synchronize SUNA Internal Clock.....93

Figure 120. Stage Crest Data (ft.) 1925-2017 USGS Station #02353000 FLNT at Newton (Red Line is Gage Height of 33.00 ft.).....94

Figure 121. Annual exceedance probability (%) vs. peak discharge (cfs), at USGS Station #02353000, Flint River at Newton. Graph generated using PeakFQ software (USGS).95



Title: NEON Preventive Maintenance Procedure: AIS Buoy		Date: 03/08/2022
NEON Doc. #: NEON.DOC.004613	Author: M. Cavileer, G. Simonds, R. Willingham	Revision: C

1 DESCRIPTION

1.1 Purpose

Routine preventive maintenance is imperative to ensure the proper functional and operational capability of National Ecological Observatory Network (NEON) systems, and the preservation of NEON infrastructure. This document establishes mandatory procedures and recommended practices for preventive maintenance of the **AIS Buoy** to meet the objectives of the NEON project, and its respective stakeholders and end users.

1.2 Scope

Preventive Maintenance is the planned maintenance of infrastructure and equipment with the goal of improving equipment life by preventing excess depreciation and impairment. This maintenance includes, but is not limited to, inspecting, adjusting, cleaning, clearing, lubricating, repairing, and replacing, as appropriate. The procedures in this document are strictly preventive and do **not** address corrective actions.

This document specifically addresses the preventive procedures for the AIS Buoy infrastructure for the seven freshwater lake sites (CRAM, TOOK, SUGG, BARC, PRPO, LIRO, and PRLA) and three river sites (FLNT, TOMB, and BLWA). This document does not comprehensively address the specific sensor instrumentation on the AIS Buoy.



Title: NEON Preventive Maintenance Procedure: AIS Buoy		Date: 03/08/2022
NEON Doc. #: NEON.DOC.004613	Author: M. Cavileer, G. Simonds, R. Willingham	Revision: C

2 RELATED DOCUMENTS AND ACRONYMS

2.1 Applicable Documents

The following applicable documents (AD) contain mandatory requirements and/or supplementary information that are directly applicable to the topic and/or procedures herein. Visit the [NEON Document Warehouse](#) for electronic copies of these documents.

AD [01]	NEON.DOC.004300	Environmental, Health, Safety And Security (EHSS) Policy, Program and Management Plan
AD [02]	NEON.DOC.004301	EHSS Environmental Protection Manual
AD [03]	NEON.DOC.004316	Operations Field Safety and Security Plan
AD [04]	NEON.DOC.001569	NEON Preventive Maintenance Procedure: AIS Surface Water Quality Multisonde
AD [05]	NEON.DOC.003808	NEON Sensor Command, Control and Configuration (C3) Document: Buoy Meteorological Station and Submerged Sensor Assembly
AD [06]	NEON.DOC.002716	NEON Preventive Maintenance Procedure: Nitrate Analyzer
AD [07]	NEON.DOC.000416	NEON Sensor Command, Control and Configuration (C3) Document: Photosynthetically Active Radiation (PAR)
AD [08]	NEON.DOC.004257	NEON Standard Operating Procedure (SOP): Decontamination of Sensors, Field Equipment and Field Vehicles
AD [09]	NEON.DOC.001166	NEON Sensor Command, Control and Configuration (C3) Document: MULTISONDE, STREAM
AD [10]	NEON.DOC.001063	NEON Sensor Command, Control and Configuration (C3) Document: UNDERWATER PHOTOSYNTHETICALLY ACTIVE RADIATION (UPAR)
AD [11]	NEON.DOC.001570	NEON Sensor Command, Control and Configuration (C3) Document: SUNA NITRATE ANALYZER, WADEABLE STREAMS
AD [12]	NEON.DOC.004608	AIS Buoy Verification Procedures
AD [13]	NEON.DOC.001972	AIS Comm Interconnect Map
AD [14]	NEON.DOC.004638	AIS Verification Checklist
AD [15]	NEON.DOC.004713	AIS Stream Nutrient Analyzer Formal Verification Procedures
AD [16]	NEON.DOC.002757	NEON Preventive Maintenance Procedure: Underwater Photosynthetically Active Radiation (uPAR)
AD [17]	NEON.DOC.004886	NEON Preventive Maintenance Procedure: Aquatic Portal & AIS Device Posts
AD [18]	NEON.DOC.004934	NEON Preventive Maintenance Procedure: Humidity and Temperature Sensor
AD [19]	NEON.DOC.001459	NEON Preventive Maintenance Procedure: Barometric Pressure Sensor
AD [20]	NEON.DOC.004429	NEON Preventive Maintenance Procedure: Radiation Sensors
AD [21]	NEON.DOC.004972	AIS Beacon Formal Verification Procedures

2.2 Reference Documents

The reference documents (RD) listed below may provide complimentary information to support this procedure. Visit the [NEON Document Warehouse](#) for electronic copies of these documents.



Title: NEON Preventive Maintenance Procedure: AIS Buoy		Date: 03/08/2022
NEON Doc. #: NEON.DOC.004613	Author: M. Cavileer, G. Simonds, R. Willingham	Revision: C

RD [01]	NEON.DOC.000008	NEON Acronym List
RD [02]	NEON.DOC.000243	NEON Glossary of Terms
RD [03]	NEON.DOC.050005	Field Operations Job Instruction Training Plan
RD [04]	NEON.DOC.002767	AIS Subsystem Architecture, Site Configuration and Subsystem Demand by Site - SCMB Baseline
RD [05]	NEON.DOC.001104	Data Generating Device DGD List and Hierarchies
RD [06]	HB07530100	Assembly, Multisonde with Sensors, FDOM, Lake
RD [07]	NEON-8181	D18-TOOK Buoy Anchor Trip Lines
RD [08]	NEON-8540	YSI Buoy Retrieval and Storage
RD [09]	HB16100010	ASSEMBLY, MAST, RADIO, PORTAL BUOY
RD [10]	HB16100000	SUBSYSTEM, DAS, PORTAL, TELEMETRY, BUOY
RD [11]	HJ13300000	KIT, AQU PORTAL, POPULATION
RD [12]	TIS Training August 2015: Guide for Annual Sensor Refresh, Rev_C (8.13.15)	
RD [13]	NEON-8659	FOPS REVIEW: NEON.DOC.004613 NEON Preventive Maintenance Procedure: AIS Lake Buoy
RD [14]	NEON.DOC.000769	Electrostatic Discharge Prevention Procedure
RD [15]	NEON-9623	AIS Buoy guidance for removing buoy/instruments due to high winds and/or flooding
RD [16]	NEON-9273	Release of SUNA Preventive Maintenance - Doc now available!
RD [17]	NEON-6824	D03 AIS Buoy incompatible with bird excrement
RD [18]	NEON-12679	D03 - AIS - Issues with SUNACOM on loaner laptops
RD [19]	NEON.DOC.004821	NEON Preventive Maintenance Procedure: Aquatic Meteorological (Met) Station
RD [20]	NEON-12997	Lake Ice On-Ice Off Dates

2.3 External References

The external references (ER) listed below may contain supplementary information relevant to maintaining specific commercial products that make up the infrastructure of the AIS Buoy. These documents are external to the NEON project and Battelle Ecology.

ER [01]	YSI, Incorporated. Vertical Profiler System (CR1000), Version 3. 19 December 2011. https://www.ysi.com/systems
ER [02]	Carmanah Technologies Corporation. M650H User Manual, Revision C. June 2014.
ER [03]	Campbell Scientific, Inc. Garmin GPS16X-HVS GPS Receiver, Revision 3/14. March 2014.
ER [04]	Precision Measurement Engineering (PME), Inc. RS232/RS485 T-Chain User's Manual. November 08, 2013.
ER [05]	Campbell Scientific, Inc. SDM-SIO1 Serial Input/output Module, Revision 7/13. July 2013.
ER [06]	Honeywell. HMR3200/HMR3300 Digital Compass Solutions User's Guide. www.magneticsensors.com
ER [07]	LI-COR. Underwater Radiation Sensors Instruction Manual LI-192 Underwater Quantum Sensor, Publication Number 984-08307. June 2006.
ER [08]	R.M. Young Company. Wind Monitor-HD Alpine Model 05108-45 Instructions, Rev. A030513 (PN: 05108-45-90), www.youngusa.com



Title: NEON Preventive Maintenance Procedure: AIS Buoy		Date: 03/08/2022
NEON Doc. #: NEON.DOC.004613	Author: M. Cavileer, G. Simonds, R. Willingham	Revision: C

ER [09]	YSI, Inc. Profile System Specifications. https://www.ysi.com/File%20Library/Documents/Specification%20Sheets/e21-vertical-profilers-spec-sheet.pdf
ER [10]	YSI, Inc. About the Vertical Profiler, Frequently Asked Questions... https://www.ysi.com/File%20Library/Documents/Specification%20Sheets/e21-vertical-profilers-spec-sheet.pdf
ER [11]	YSI, Inc. Field Survival Guide Checklist for Environmental Sondes. https://www.ysi.com/File%20Library/Documents/Guides/Field-Survival-Guide.pdf
ER [12]	YSI, Inc. Care, Maintenance, and Storage of YSI 6-Series Probes and Sondes. https://www.ysi.com/File%20Library/Documents/Technical%20Notes/T601-Care-Maintenance-and-Storage-of-YSI-6-Series-Probes-and-Sondes.pdf
ER [13]	LICOR, Inc. LI-192 Underwater Quantum Sensor, https://www.licor.com/env/products/light/quantum_underwater.html
ER [14]	LICOR, Inc. LI-COR Underwater Radiation Sensors Instruction Manual, https://www.licor.com/documents/285ymmolackajidu9wao
ER [15]	RM Young Company. Model 05108-45 Wind Monitor – HD (Heavy Duty Alpine) Replacement Parts, January 2017. http://www.youngusa.com/Replacement%20Parts/05108-45-95(A122016).pdf
ER [16]	YSI, EXO User Manual Advanced Water Quality Monitoring Platform, Revision G. https://www.ysi.com/File%20Library/Documents/Manuals/EXO-User-Manual-Web.pdf
ER [17]	Kipp & Zonen B.V., Instruction Sheet: PQS1 (PAR Quantum Sensor). http://www.kippzonen.com/Download/425/Instruction-Sheet-PAR-Quantum-Sensor-PQS1
ER [18]	Cole-Palmer Instrument Company, LLC. MasterFlex L/S Operating Manual: Pump Drives, Model No. 07533-50, 60, 70, 80. Edition 6. https://pim-resources.coleparmer.com/instruction-manual/a-1299-0519.pdf
ER [19]	Cole-Palmer Instrument Company, LLC. MasterFlex L/S Operating Manual: Easy-Load II Pump Heads. https://pim-resources.coleparmer.com/instruction-manual/77200-62.pdf

2.4 Acronyms

2D	Two Dimensional	MET	Meteorological
A/R	As Required	MSDS	Material Safety Data Sheet
AIS	Aquatics Instrument System	OBGI	On-Board User Interface
AQU	Aquatic	P/N	Product Number or Part Number
BARC	Barco Lake (D03CA2)	PAR	Photosynthetically Active Radiation
BLWA	Black Warrior River (D08RA1)	PDS	Power Distribution System
CFG	Configuration	PFD	Personal Floatation Device
CNC	Command and Control	PPE	Personal Protective Equipment
CRAM	Crampton Lake (D05CA1)	PRLA	Prairie Lake at Dakota Coteau Field School (D09RA1)
CVAL	Calibration, Validation, and Audit Laboratory	PRPO	Prairie Pothole (D09CA1)
DAS	Data Acquisition System	S-2	In-Stream Sensor Set, Downstream
DMM	Digital Multi-Meter	SUGG	Suggs Lake (D03CA1)
DO	Dissolved Oxygen	SUNA	Submersible Ultraviolet Nitrate Analyzer
ESD	Electrostatic Discharge	T-Chain	Temperature Chain



Title: NEON Preventive Maintenance Procedure: AIS Buoy		Date: 03/08/2022
NEON Doc. #: NEON.DOC.004613	Author: M. Cavileer, G. Simonds, R. Willingham	Revision: C

fDOM	Fluorescent Dissolved Organic Matter	TIS	Terrestrial Instrument Sites
FLNT	Flint River (D03RA1)	TOMB	Lower Tombigbee River (D08RA2)
GPS	Global Positioning System	TOOK	Toolik Lake (D18)
HMP	Humidity and Temperature Probe	uPAR	Underwater PAR
IR	Infrared	USCG	United States Coast Guard
JSA	Job Safety Analysis	UTC	Universal Time Coordinated
LC	Location Controller	UV	Ultraviolet
LED	Light-Emitting Diode		
LIRO	Little Rock Lake (D05RA1)		
LOGWAR	Logistics Warehouse		

2.5 Terminology

The use of common names for NEON instrumentation and subsystems vary across departments and domains. This section aims to clarify and associate the common names with the technical names herein. The aim of this section is to marry up terms under one name so Technicians are aware of the component referenced in the procedures herein, but also aware they may be called another term in a group discussion with headquarters or training staff.

SYNONYMOUS COMMON NAME(S)	NEON TECHNICAL REFERENCE NAME
YSI Vertical Profiler System (CR1000), Buoy Meteorological Station and Submerged Sensor Assembly for River and Lake locations	AIS Buoy
Level Winder, Axle Rod	Axle
Vaisala Barometer	Barometric Pressure sensor
Lakebed PAR, Down facing, Outgoing PAR, Underwater PAR (uPAR)	Upwelling PAR
Surface Water PAR, Up facing, Incoming PAR, uPAR	Down-Welling PAR
Charge Regulator	Charge Controller
JIRA, ServiceNow	NEON Issue Management and Reporting System
MAXIMO	NEON Asset Management and Logistic Tracking System
Sonde, Water Quality	Multisonde
Aquatics Instrument System (AIS) power distribution system (PDS) and data acquisition system (DAS), Portal <i>Note: Equivalent to the Instrument Hut for Terrestrial Instrument System (TIS) sites.</i>	Aquatic Portal



3 SAFETY AND TRAINING

Personnel working at a NEON site must be compliant with safe fieldwork practices in AD [01] and AD [02]. The Field Operations Manager and the Lead Field Technician have primary authority to stop work activities based on unsafe field conditions; however, all employees have the responsibility and right to stop work in unsafe conditions.

All technicians must complete safety training and procedure-specific training to ensure the safe implementation of this protocol per AD [03]. Refer to the site-specific EHSS plan via the [NEON Safety document portal](#) for electronic copies and conduct the appropriate Job Safety Analysis (JSA) before conducting any preventive maintenance.

Personal Protective Equipment (PPE) may be required in some decontamination procedures to maintain safe working conditions (e.g., use of equipment such as power washers, air compressors), and disinfectants. For this reason, personnel should be trained and familiar with the Material Safety Data Sheets (MSDS) for the cleaning solutions, tools and equipment necessary for decontamination of the sensor sets herein.

Technicians must not enter the water without water safety training and a personal floatation device (PFD), and must display basic competency in boat operation, regardless of whether or not boat operation is a primary responsibility.

Be aware of flow events prior to visiting the site. Tie off the Domain boat to the AIS Buoy prior to boarding (**Figure 1**).

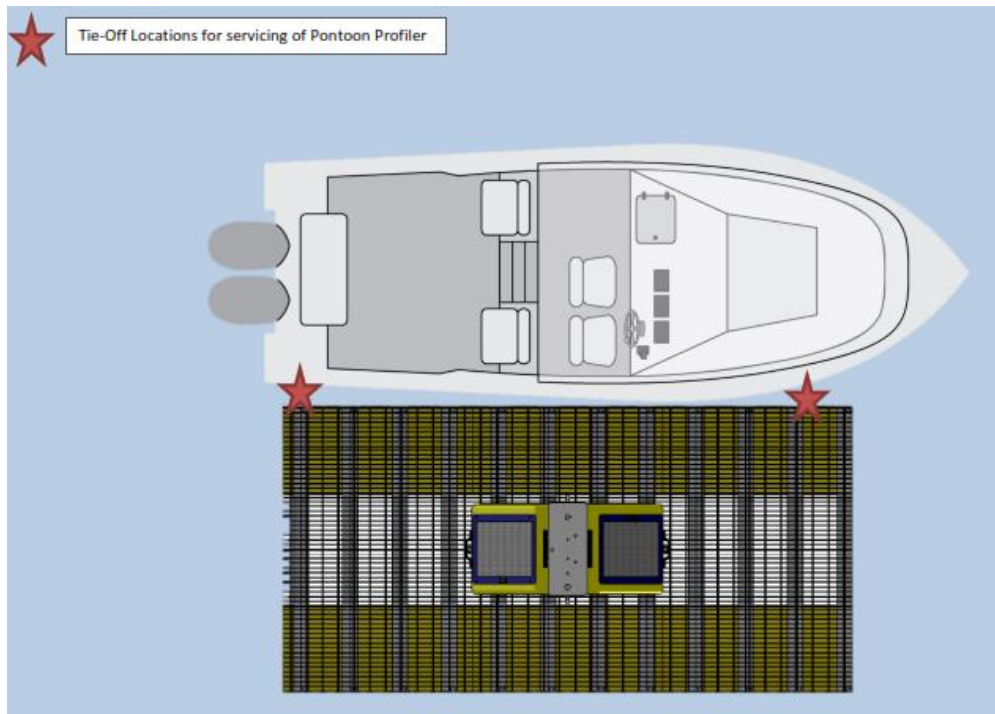

Figure 1. Tether Domain Boat to AIS Buoy Deck Cleats - Two Tie-offs for Lakes/One Tie-off for Rivers



Tether the Domain boat to two deck cleats at lake sites and one deck cleat at river sites. (One tie-off enables FOPs to react and respond faster in the event of a person falling overboard with regard to the river currents.) **Figure 2** displays the Domain’s boat tethered to the AIS Buoy deck cleat at Domain 03, Flint River.

Maintain cognizance of weight distribution if more than one Technician is onboard and during the removal/reinstallation of equipment. Place the T-Frame fiberglass covers in the Domain boat to prevent knocking the covers overboard during maintenance activities. If unable to place the covers in the Domain boat, fashion a leash using rope and a carabineer to secure the covers to the deck from their handles.

The AIS Buoy winch system contains Mobil SHC 624 lubricant, which requires an MSDS. The gearbox using this lubricant does not contain any user-serviceable parts and not part of BEI’s preventive maintenance procedure for the AIS Buoy winch assembly. Do not open this compartment for any reason.

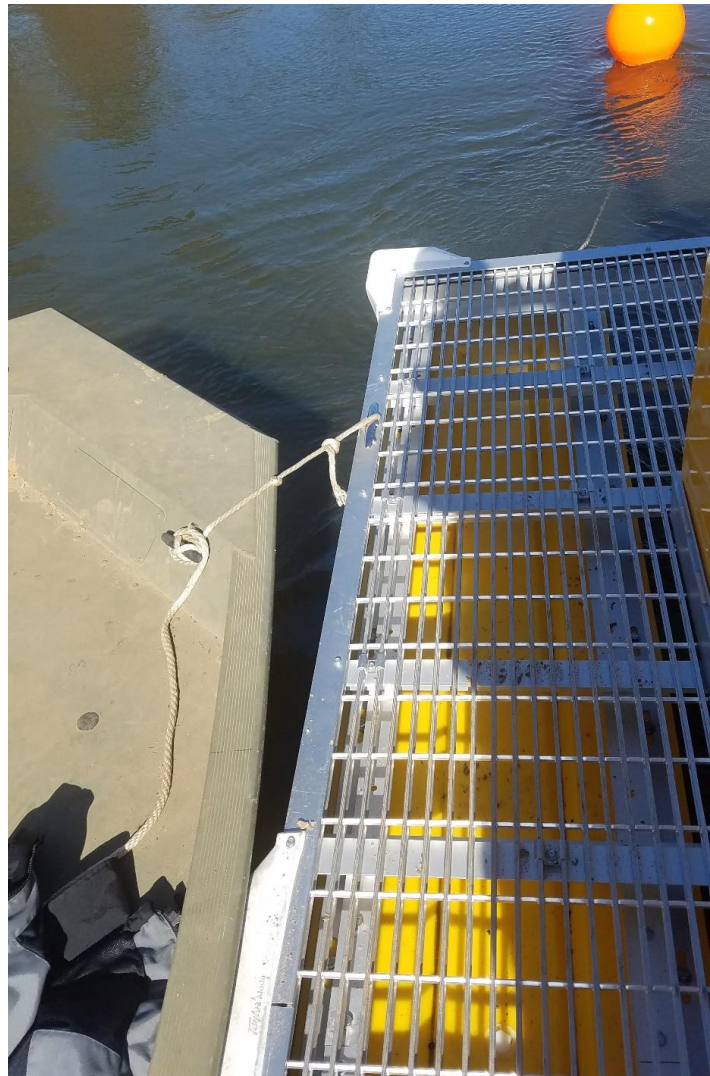

Figure 2. Domain Boat Tethered to AIS Buoy (D03 FLNT)

Please be aware, there is a risk of hurting hands/feet caught between the dual PAR SUNA mount and bracket. Maintain awareness of this risk when pulling the two Photosynthetically Active Radiations (PARs) and Submersible Ultraviolet Nitrate Analyzer (SUNA) out of the water. Figure 3 displays the bracket on the floating deck where hands/feet could encounter scissor/pinch injury when pulling the dual PAR SUNA mount of the water.

In the event the current method to conduct the procedures herein are no longer safe for use due to unforeseen or unknown site dynamics, consult with the NEON Safety Office via the NEON Project’s Issue Management and Reporting System (i.e., JIRA or ServiceNow) for alternative methods to conduct AIS preventive/corrective maintenance and Sensor Refresh procedures.

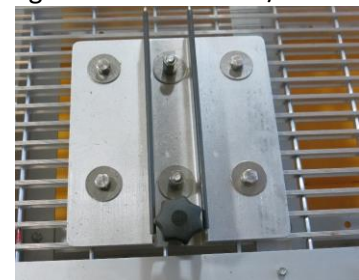

Figure 3. Dual PAR SUNA Mount Bracket - Scissor Risk Safety Note!



4 SENSOR OVERVIEW (SENSORS ONLY)

4.1 Description

The AIS Buoy is a floating platform that includes an integrated meteorological (MET) station, an in-situ aquatic sensor set that includes; a fixed underwater measurement set, and a profiling underwater measurement set (see **Figure 4**). The buoy instrumentation deploys to measure a suite of biogeochemical and atmospheric parameters to enable a greater understanding of how freshwater aquatic ecosystems respond to global and environmental change.

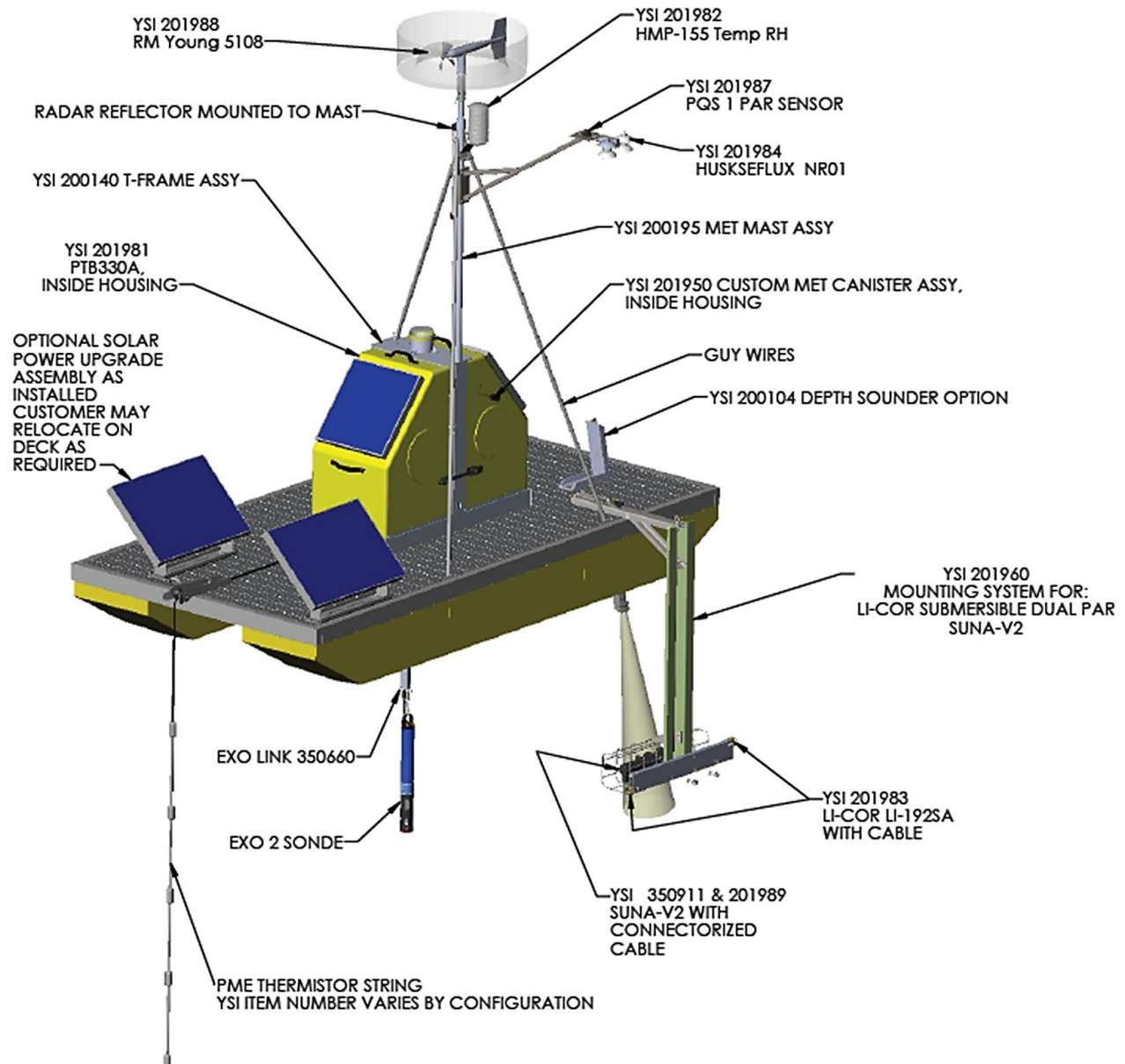

Figure 4. AIS Buoy Sensor Components and Infrastructure



Standard Components (Figure 4):

- Floating Platform (Grated Deck on pontoons)
- T-frame with fiberglass T-frame cover
- Winch assembly
- Antenna assembly
- Beacon
- Depth sounder
- Meteorological (MET) Mast: Wind monitor mount, Temp Humidity and Radar reflector

Site-Specific Partially Custom Components (Figure 4):

- PSQ1 mounting
- Power upgrade assembly: Solar panels on fiberglass T-frame cover & auxiliary solar panels on floating platform
- Temperature chain (T-chain): Custom chain with standard mount

NEON Custom Components:

- Dual photosynthetically active radiation (PAR)/submersible ultraviolet nitrate analyzer (SUNA) mount
- Barometer mounting (under T-frame)
- Connectorized pressure case assembly, MET-Global Positioning System (GPS)
- Met mast: SUNA radio antenna (not pictured) and NR01 mount

4.1.1 Domain 03 Flint River (FLNT) AIS Buoy

The AIS buoy is the same for both lake and river sites with the exception of Domain 03, Flint River (FLNT) in Georgia. FLNT recorded hydrologic history suggest flow regime that includes frequent high water events and frequent drought cycles. The need to build a buoy capable of withstanding large-scale fluctuation made it necessary to design unique components for the FLNT buoy.ⁱ The design changes attempt to decrease risks to the instrumentation and infrastructure from the known volatility of the river.

Domain 03 Flint River (FLNT) AIS Buoy Design (Figure 5):

- Uses two Multisonde sensors
- Peristaltic pump profiling system, which connects to a Multisonde under the T-frame, above water
- Upwelling/down-welling PAR retractable mounting system
- Location of Temp chain and sensor weight to attempt to keep the chain linear underwater
- Mounts for a Multisonde and a SUNA in fixed positions under the deck grate
- No winch assembly; profiler canister powers the pump system (i.e., Pump Profiler Canister)
- No depth sounder



- No EXO Link with the Multisondes

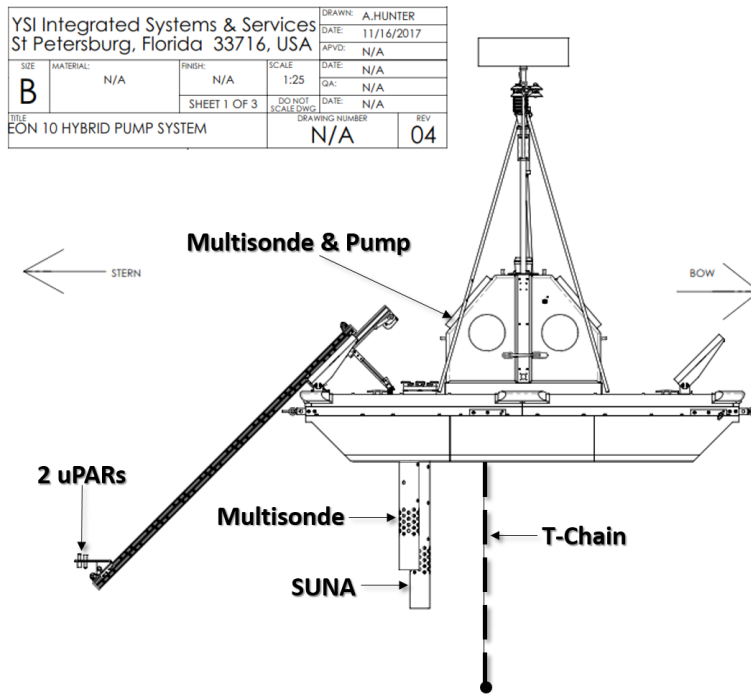

Figure 5. D03 FLNT River Buoy Mechanical Drawing (Source: YSI Integrated Systems & Services)

4.2 Sensor Specific Handling Precautions

Aquatic Technicians must employ special care to avoid dropping solutions, hardware, or tools into the water while working to prevent contaminating an aquatic environment. In addition, per NEON.AIS.4.1735, all vehicles, trailers, boats, tools, protective outerwear, and any other items that encounter an aquatic or riparian environment, require decontamination prior to site access [AD \[08\]](#).

4.2.1 Multisonde Handling Precautions

When handling the probe sensors within the Multisonde, **do NOT touch the ends of the pH and Dissolved Oxygen (DO) probe**. During transport or short-term storage (i.e., within two weeks), ensure all sensor probes connect to the Multisonde and cap empty ports. Install a calibration cup containing 1 cm of water on the Multisonde body with the probes. Thread the cup tight enough to prevent evaporation. This is most important for the Cond/Temp, DO, and pH sensor probes. *Reference AD [04] for additional guidance specific to the Multisonde.*

4.2.2 PAR Handling Precautions

The PARs contain sensitive optical components. Do not use a dry brush to remove biofouling from these sensors. Use care when positioning or adjusting the sensor; do not touch the sensor head. Dirt and oils on hands may cause biases in measurement collection.



4.2.3 Buoy Electronics

Employ electrostatic discharge (ESD) procedures when handling buoy electronics, such as the Profile and MET Canisters. This includes the Oz Grape that powers the radio in the Aquatics Portal that receives/transmits to the AIS Buoy radio and receives data from the SUNA radio. Never “hot swap” any Grape sensor/subsystem connections; always remove the Ethernet Cable (Cat 5/RJF) before connecting/disconnecting other connections. Reference RD [14].

4.3 Operation

Figure 6 provides a functional overview of the data transmission, power system, sensors and navigation equipment for the AIS Buoy. The red lines are power connections and the blue lines are Comm connections (data) in Figure 6.

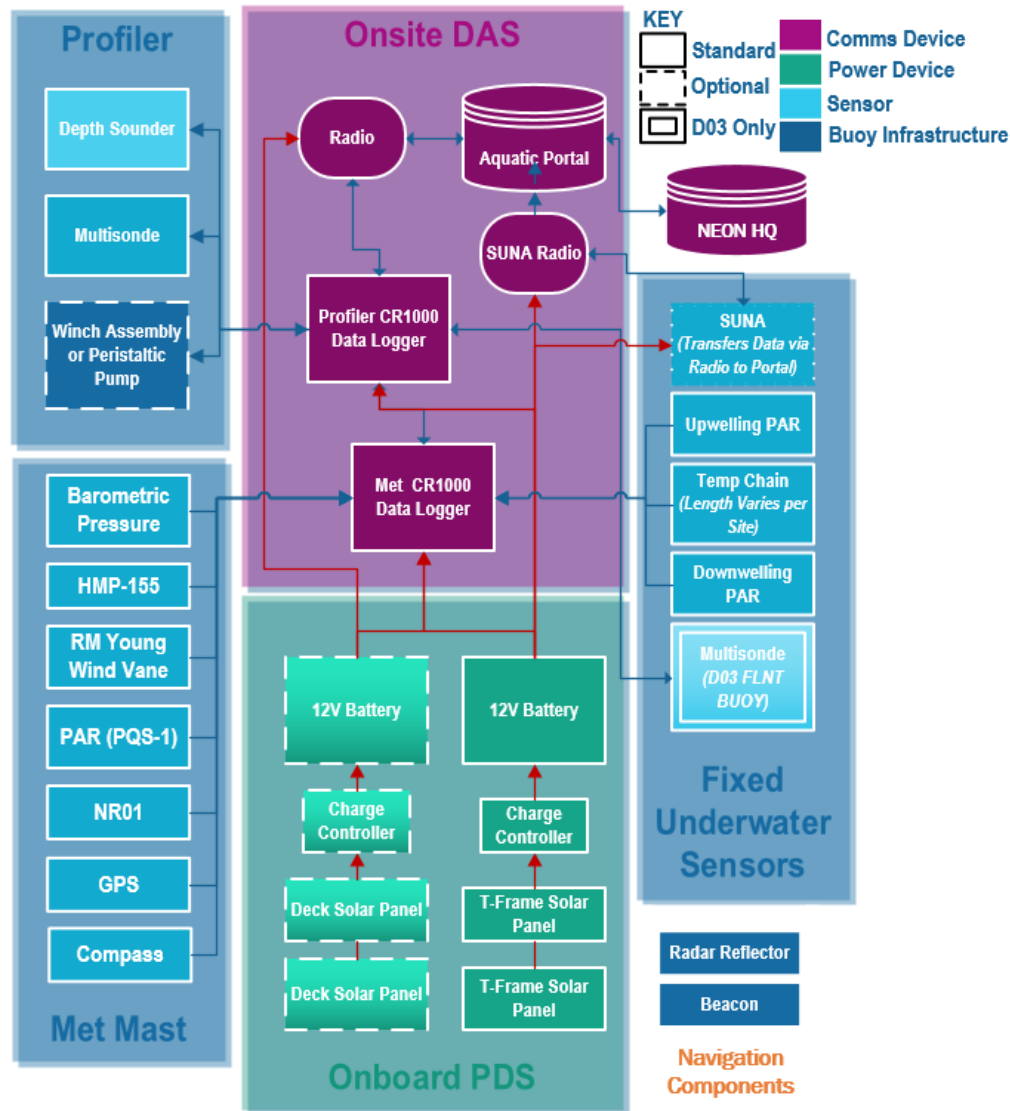

Figure 6. AIS Buoy Operational Overview with Power Distribution System (PDS) and Data Acquisition System (DAS)



<i>Title:</i> NEON Preventive Maintenance Procedure: AIS Buoy		<i>Date:</i> 03/08/2022
<i>NEON Doc. #:</i> NEON.DOC.004613	<i>Author:</i> M. Cavileer, G. Simonds, R. Willingham	<i>Revision:</i> C

The AIS Buoy features twelve distinct sensor types that provide 14 data products. Two Campbell Scientific data loggers capture the sensor sets data and transmits it via radio to the Aquatic Portal onshore. The only exception is the data from the SUNA, which transmits directly via a radio dedicated specifically to that sensor (this is due to CR1000 usage limits). On-board solar panels and batteries power the sensors during deployment.

According to NEON.AIS.4.1596, AIS shall make the following underwater measurements on the buoy: chlorophyll a, dissolved oxygen, pH, turbidity, upwelling and down-welling uPAR, water conductivity, water temperature, fluorescent dissolved organic matter (fDOM), nitrate, and above-water surface radiation (PAR).

According to NEON.AIS.4.1524, AIS shall make the following measurements at the aquatic land-based and buoy-based meteorological stations: air temperature, down-welling above-water PAR, incident and reflected shortwave and longwave (net) radiation, horizontal wind speed and direction, barometric pressure and humidity.



5 INSPECTION AND PREVENTIVE MAINTENANCE

5.1 Equipment

Table 1 lists a summary of the preventive maintenance equipment necessary to conduct the procedures herein. Equipment recommendations and applicability may adjust over time as the implementation of NEON sensors and subsystems mature.

Table 1. AIS Buoy Preventive Maintenance Equipment List

P/N	NEON P/N	Description	Quantity
Tools			
NEON, IT		Rugged tablet / Laptop with USB-3.0 port	1
		YSI Serial Cable (9-pin female DB9 to 4-pin, plus a key pin that looks like 5 pins, circular connector cable to connect to Buoy)	1
NEON	HB09780000	SUNA-V2 Cable (to connect to the SUNA V-2)	
		USB to Serial Adapter (to connect to SUNA Radio)	A/R
		USB A to mini-B Cable	1
FLUKE-1AC-A1-11	MX102703	Digital Multi-Meter (DMM) (to measure 12V Battery Voltage)	1
69899		M650H Beacon Infrared Remote (IR) Programmer (to access beacon state of health on buoy)	1
GENERIC		Measuring Tape	1
GENERIC		Scissors (to remove cable dressings) & Flush cutters (for zip ties)	1
599810	0320170022	EXO Signal Output Adapter – USB (for field calibration)	1
599316	0337890000	EXO2 Calibration/Storage Cup (for field calibration)	1
599469	0338050000	EXO Replacement Sensor Tool and Magnet Activation Kit	1
599594		EXO Tool Kit: Replacement Parts for Maintaining the EXO Sonde (two sensor removal/Bluetooth activation tools, one battery cover tool, and one syringe for cleaning the depth port)	1
GENERIC		5-Gallon Bucket (for field calibration/prevent contamination spills)	1
YSI		EXO USB Adapter Driver (for field calibration)	1
GENERIC		$\frac{9}{16}$ " Combo Wrench	1
GENERIC		$\frac{1}{2}$ " Combo wrench	1
GENERIC		$\frac{1}{2}$ " Open-End Wrench	1
GENERIC		$\frac{3}{16}$ Allen Wrench (to remove Beacon and other components)	1
GENERIC		Crescent Wrench	1
GENERIC		Flathead Screwdriver (to remove canisters and PARs)	1
GENERIC		Dry Brush or equivalent (to clean off animal excrement or biofouling)	1-2
GENERIC		Knee Pads (to work on floating platform/deck)	1 Pair
GENERIC		Gloves or equivalent (to pull up the dual PARSUNA Mount)	1 Pair
GENERIC		Boat (to access the AIS Buoy on water)	1
GENERIC		Trailer (to tow the AIS Buoy on land)	1
GENERIC		Cable/Bike Lock (to temporary secure the buoy on land)	1
		Handheld Compass (to measure Digital Compass offset)	1
		Digital Level (to measure Pitch and Roll offsets)	1
GENERIC		Channel Locks (for mooring shackles)	1
GENERIC		Pliers (for cotter pins on mooring shackles)	1
GENERIC		Pipe wrench (for seized mooring shackles)	A/R



Title: NEON Preventive Maintenance Procedure: AIS Buoy		Date: 03/08/2022
NEON Doc. #: NEON.DOC.004613	Author: M. Cavileer, G. Simonds, R. Willingham	Revision: C

05194		RM Young Propeller Nut Wrench or 7/16 wrench (to remove wind vane propeller for shipping and handling)	1
GENERIC		Boat Hook (to adjust river mooring system/release FLNT sensor tubes)	1
GENERIC		11-in-1 (for pump maintenance or to remove components)	1
202309380		2-3/4 in. Stainless-Steel Clamp Hose Clamp (Bump Stop for Buoy)	1-2
Consumable Items			
57383		M650H Beacon Replacement Battery Pack Kit	1
599352		Krytox 205 Grease (for Multisonde and Winch Assembly)	1
210-01958-1		LI-COR Dow Corning 111 (silicone grease for PAR sensors)	1
0719752		Fastenal 7" Zip Ties, Black, UV Stabilized Nylon	A/R
0719793		Fastenal 14" Zip Ties, Black, UV Stabilized Nylon	A/R
3824	0320170013	Calibration Solution - pH buffer for YSI EXO, Assorted Case of pH Values (for Multisonde Calibrations)	1 Case
		Deionized Water (for SUNA Calibrations)	2L
		Para film (for SUNA Calibrations)	A/R
		Alkaline D-Cell Batteries or NiMH D-cell Batteries with a minimum rating of 10,000 milliamp hours (Multisonde internal batteries)	4
GENERIC		Rope (to tow AIS Buoy to land)	A/R
GENERIC		Large Tarp (for temporary storage of the buoy)	1
	MX104219	Red Rejected Tag (for Defective Assets sending back to BEI HQ)	A/R
GENERIC		Bird Deterrents – Plastic Stick-on Spikes, etc. (for solar panels)	A/R
599681	0337940000	EXO2 Replacement O-Ring Kits (for Multisonde Maintenance – inspect these when replacing the internal D-cell batteries)	1
07533-01		Motor Brushes, set of two (for D03 FLNT Pump Drive)	1
7177K66	0365120000	Zip-Tie, 8" Long, 0.5" Wide, 2" Cable Bundle (for D03 FLNT T-Chain)	1
Resources			
YSI_VPS_30.4.dld		YSI Profile Wizard (Campbell Scientific LoggerNet™ Software) https://www.campbellsci.com/loggernet Download trial and use serial activation key from physical CD given to Domain by YSI.	1
		MetStation_6.9.CR1 (Campbell Scientific LoggerNet™ Software)	1
		PuTTY (to ping Grape at MET Station): http://www.putty.org/	A/R
1.0.12 or later		KOR-EXO Software (for Multisonde Calibration/Validation) http://www.exowater.com/manuals-software.php Enter the serial number from your Multisonde to acquire download access.	1
		Multisonde Firmware Files	1
		SUNAcom/Seabird UCI (for SUNA Calibration) http://www.seabird.com/software/uci	1
		FTDI Driver http://www.ftdichip.com/FTDrivers.htm (use with BEI loaner laptops)	A/R
		XCTU Software (for SUNA Radio Configuration) https://www.digi.com/products/xbee-rf-solutions/xctu-software/xctu	A/R
		Win-Situ: https://in-situ.com/support/documents/win-situ-5-software/	1
		Covered storage facility or environmentally-controlled storage facility	A/R

5.2 Subsystem Location and Access

AIS Buoys reside on fresh water lakes and/or rivers within specific Domains. **Figure 7** is an example of a successful AIS Buoy deployed in Domain 09, Prairie Pothole (PRPO). Sensor subsystems reside on the AIS Buoy and within the onshore Aquatic Portal.



Figure 7. AIS Buoy for Domain 09 Prairie Pothole (PRPO) Lake

Figure 8 is an example of an AIS Buoy deployed in Domain 03, Flint River (FLNT). The design for the AIS Buoy in Figure 8 is different from our standard AIS Buoy design to account for location dynamics/variables. With the exception of the AIS Buoy in Figure 8, lake and river AIS Buoy designs are the same (Figure 4 is an example of the standard AIS Buoy design and Figure 5 displays the differences for D03 FLNT AIS Buoy).



Figure 8. AIS Buoy for Domain 03 Flint River (FLNT)

5.3 Maintenance Procedure

Table 2 is an interval schedule of each infrastructure component requiring preventive maintenance.

Table 2. AIS Buoy Preventive Maintenance Frequency Summary

AIS Buoy Maintenance		Bi-Weekly	Quarterly	Bi-Annual	Annual	As Needed	Type
Infrastructure Inspection							
	Floating Deck & pontoons			X		X	P
	Mooring System	X	X				P
	T-Frame Cover & T-Frame		X				P



AIS Buoy Maintenance		Bi-Weekly	Quarterly	Bi-Annual	Annual	As Needed	Type
	GPS, Beacon, and Antenna Mounts to T-Frame		X				P
	T-Frame Cover & T-Frame		X				P
	Winch Assembly		X				P
	PVC Canister Connections & Instrumentation Cables/Cabling		X				P
	Batteries & Battery Enclosures			X			P
	Solar Panels and their Mounts		X				P
	MET Mast Mount & Guy-wires		X				P
	SUNA Radio Antenna & Mount		X				P
	Radar Reflector & Zip Ties		X				P
	Dual PAR SUNA Bracket & Mount, Cage and Connections		X				P
	Retractable uPAR Mounting System (D03 FLNT Only)		X				P
	Fixed Underwater Sensor Tubes (D03 FLNT Only)	X					P
	Depth Finder, Mount & Cable		X				P
	T-Chain Mount, Rope & Zip Ties		X				P
	Clean Buoy Infrastructure from Animal Excrement & Bio-fouling	X				X	P
Winch Assembly: See Section 5.3.3 Winch Assembly Maintenance.							
	Visual Inspection		X				P
	Axle Lubrication				X		P
AIS Buoy Peristaltic Pump System: See Section 5.3.4 D03 FLNT ONLY: Peristaltic Pump Maintenance.							
	Visual Inspection	X					P
	Clean/Remove Biofouling	X				X	P
	Check Overflow Tube is Above Water for Flow Cell	X					P
	Replace Pump Drive Motor Brush			X			P
Mooring System							
	Mooring Line Adjustments		X	X	X	X	P
	Debris Removal	X				X	P
Seasonal Storage Requirements: See Section 5.3.6.2 Seasonal Storage.							
	Check Beacon Batteries	~X					P
	Check Buoy 12V Batteries	~X				X	P
	AIS Buoy Infrastructure/Instruments in Storage Visual Inspection	~X				X	P
Sensor Instrumentation							
	Visual Inspection	Reference Instrument-specific Preventive Maintenance Documents.					



AIS Buoy Maintenance		Bi-Weekly	Quarterly	Bi-Annual	Annual	As Needed	Type
	Remote/Onsite Diagnostic Monitoring	X				X	P
	Clean Biofouling from uPARs	X					P
	Clean Biofouling from SUNA optics & body (Source: AD [06])	X					P
	Clean Multisonde Probes & Check Wiper/Cables for Bio-fouling (Source: AD [04])	X					P

Type: P = Preventive, X = Indicates preventive maintenance task time interval may increase due to environmental (season/weather) or unforeseen/unanticipated site factors.

5.3.1 Remote Monitoring

Two software programs control the buoy: **YSI Profile Wizard** and **MetStation_6.9.CR1**. Reference [AD \[05\]](#) for information on the command, control and configuration of the AIS Buoy.

5.3.2 AIS Buoy Infrastructure Inspection

Conduct a visual inspection on the following components to verify structural integrity of the AIS Buoy.

1. Inspect the Floating deck grates and pontoons.
 - a. Each pontoon attaches to the floating deck in three sections. Inspect each attachment point to ensure each section is secure. **Figure 9** is an example of an attachment point.
 - b. Remove animal excrement and biofouling¹ using lake water and dry brush.

PRO TIP: Purchase plastic bird spikes (anti-perching spike kit) at a local hardware store to add to the edge of the solar panels if birds are becoming a nuisance.



Figure 9. Attachment Points for Floating Deck & Pontoon

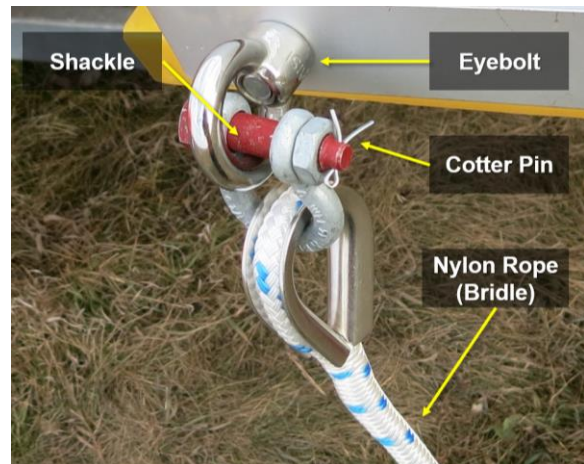

Figure 10. Mooring Bridle Attachment to AIS Buoy

¹ **Biofouling:** The accumulation of water borne organisms -- such as bacteria, protozoans, algae, and crustaceans -- on the surfaces of engineering structures (e.g., sensors and equipment) in water that leads to corrosion and inefficiency of moving parts. Source: NEON.DOC.004257



2. Inspect the Mooring system components that are subject to the environment above water or under tension most frequently (e.g., subject to more ultraviolet rays/animal excrement or pull from wind/water currents). This includes the mooring eyebolts and bridles.
 - a. Ensure the four mooring eyebolts are secure on the floating deck bow and stern.
 - b. Ensure mooring bridle is secure to eyebolts via deck with shackles and shackle cotter pins are bent (see **Figure 10**).
 - c. Inspect the shackles of the bridle on the anchor end, too (see **Figure 11**). Use a boat to access, if necessary, and pull on the rope to lift shackles. If you use the buoy to access, it may require some muscle to lift the anchor chain to enable these shackles to become visible for inspection.



Figure 11. Shackles at the Anchor End of Bridle with Line Floats

- d. Inspect the bridle nylon rope for UV damage and the shackles and cotter pin for rust/corrosion (see **Figure 12**).

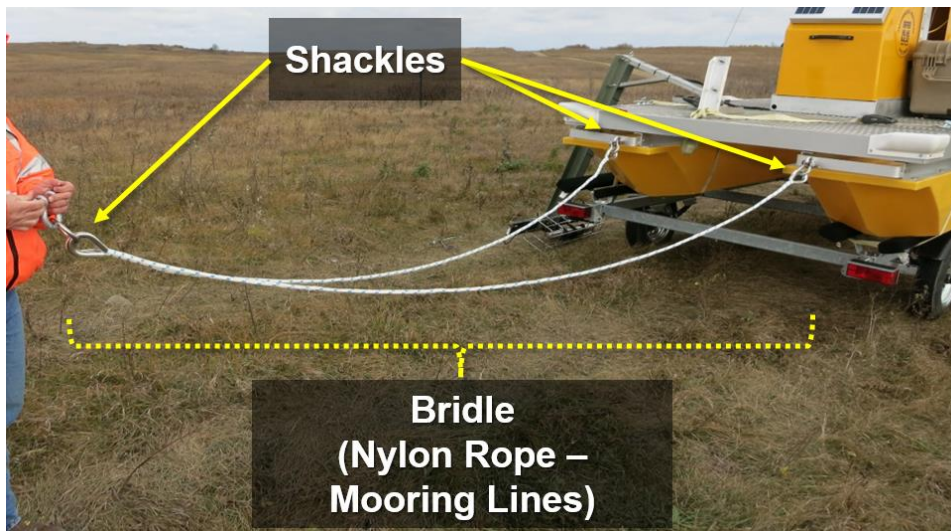

Figure 12. Bridle Attachment Points Example (What to Expect in the Water)

- e. Inspect other mooring lines, trip lines, and orange/red circular line floats for wear/damage.



- f. Free exposed wood debris caught in the mooring system (**Figure 13**). This may occur more frequently at river locations.

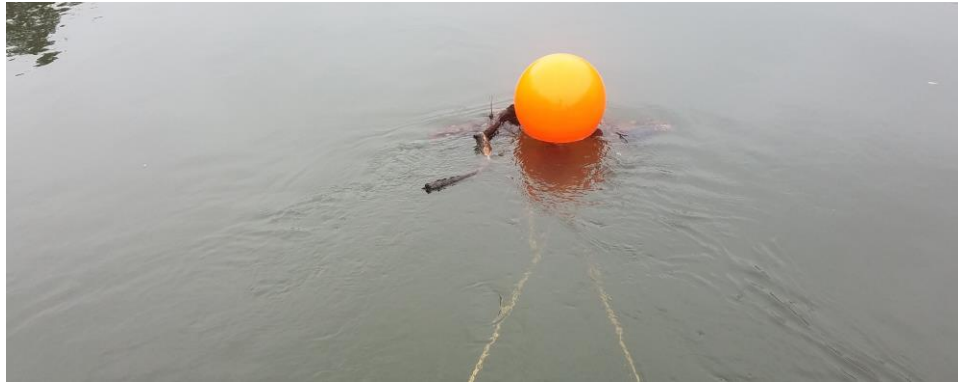

Figure 13. Exposed Wood Debris in AIS Buoy Mooring Lines (D03 FLNT)

- g. Ensure the mooring lines do not move ± 45 degrees. See *Section 5.3.5* for more information on adjusting the mooring lines to accommodate water level changes.
- 3. Inspect the fiberglass T-frame cover and T-frame for structural integrity. ***The handles for the fiberglass T-Frame cover are not for lifting purposes; they guide the housing on and off the track.***
 - a. Tighten or replace loose nuts, bolts, washers, as applicable.
 - b. Ensure the GPS, Beacon, and Antenna securely mount to the T-frame (see **Figure 14**).

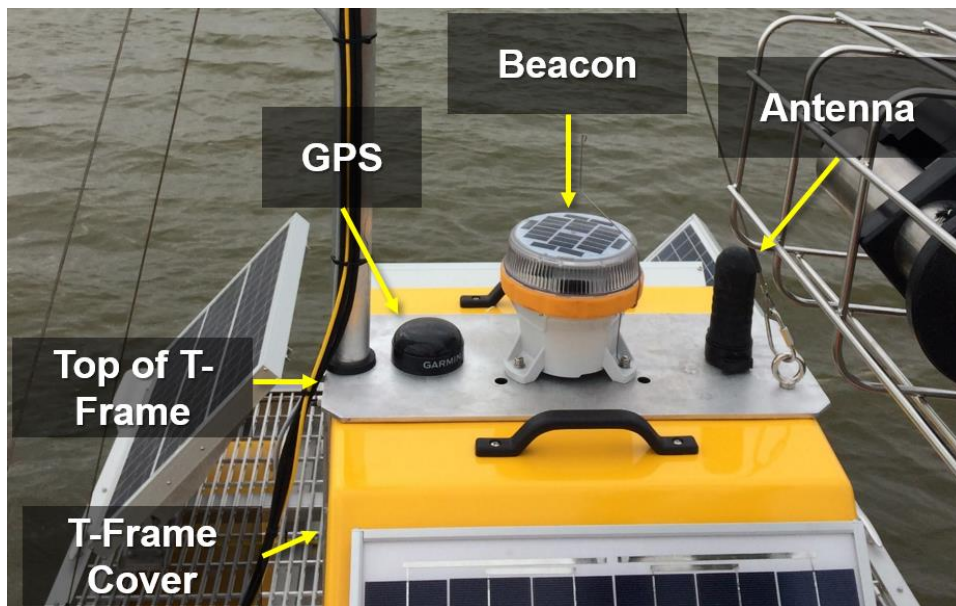



Figure 14. T-Frame: GPS, Beacon and Antenna

- a. The GPS (GPS16X-HVS) receiver plugs directly into the Campbell Scientific CR1000 data logger. The GPS antenna should have a clear view of the sky. (Do not expect the GPS antenna to work indoors.) The GPS contains no user serviceable parts for preventive maintenance; reference ER [03] for configuration and wiring instructions, in the event corrective action is necessary.



- b. Clean off any debris on the top of the Beacon (M650H) and solar panels, with water. The beacon contains no user serviceable parts with exception of charging the battery pack when the AIS Buoy is in seasonal storage. See *Section 5.3.6.2 Seasonal Storage* for instructions on storing the beacon.
- c. The antenna in **Figure 14** transmits data from the AIS Buoy to the Aquatic Portal (with exception of the SUNA, which has its own radio and a separate antenna that mounts to the MET Mast). Ensure the AIS Buoy antenna is secure to the T-Frame and there are no visible signs of damage/degradation.
4. Inspect the Winch Assembly that attaches to the T-frame. This includes the motor and motor gear, axle, drum, winch belt, and slip ring cover.
 - a. Tighten or replace loose nuts, bolts, washers, as applicable.
 - b. See *Section 5.3.3 Winch Assembly Maintenance* for additional information.
5. Inspect the two PVC Canister port connections and cabling.
 - a. Inspect seals and ensure connections are properly seated, secure and accurate per [AD \[13\]](#).
 - b. A humidity sensor and a bag of desiccant reside inside the canisters. See *Section 8 APPENDIX A: Checking for Humidity in the Profile/MET Canisters* for the procedure to check the humidity inside the canisters to determine when/if the desiccant requires changing or leak(s) exist.
 - c. Ensure cables dressed with zip-ties are not causing any strain on sensor cables/connections. Replace zip-ties, as appropriate.
 - d. See **Figure 15** and **Figure 16** for AIS Buoy port mapping to the Profiler and MET PVC canisters.

 *Note: The SUNA is unique among the AIS Buoy sensor sets since data transmission occurs via Radio. The Radio box connects directly to the battery power to power the SUNA.*



Title: NEON Preventive Maintenance Procedure: AIS Buoy		Date: 03/08/2022
NEON Doc. #: NEON.DOC.004613	Author: M. Cavileer, G. Simonds, R. Willingham	Revision: C

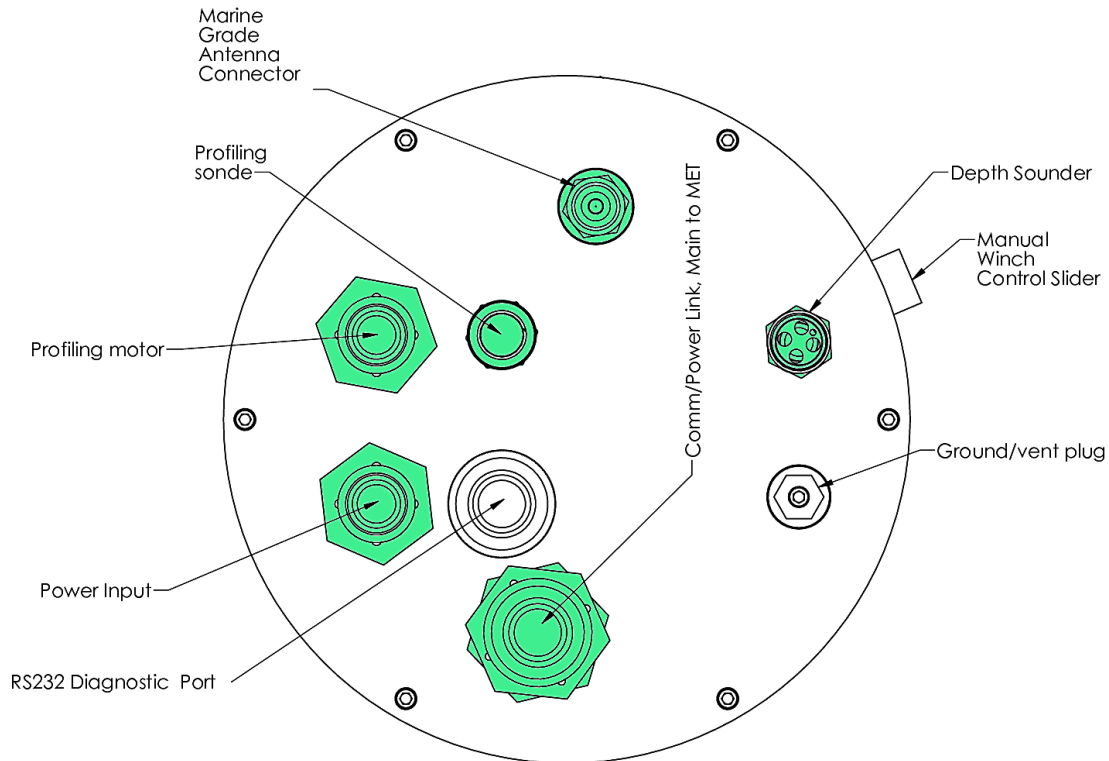

Figure 15. Profiler Canister Port Mapping (Source: AD [13])

Use Table 3 with Figure 15 to clarify the port naming convention on the Profiler Canister.

Table 3. YSI Profiler Port Mapping for Profiler Canister Decoded

Figure 15. Profiler Canister Port Mapping

Marine Grade Antenna Connector	Buoy Antenna (sits on T-Frame next to GPS for all locations with the exception of TOMB).
Profiling Sonde	Multisonde power/data connection.
Profiling Motor	Winch Assembly power connection. <i>Please be aware it is easy to damage the pins/rotate the connector if this is a rubber connector versus hard plastic. It may fail to make contact with the pins and stick into the rubber material instead.</i>
Power Input	12V Battery to Profiler PVC Canister power connection. <i>Please be aware it is easy to damage the pins/rotate the connector if this is a rubber connector versus hard plastic. It may fail to make contact with the pins and stick into the rubber material instead.</i>
RS232 Diagnostic Port	Connect NEON Laptops here to communicate with Profiler/MET Software.
Manual Winch Control Slider	Use a magnetic wand here to place the AIS Buoy into Set-up Mode and manually move the Winch Assembly with the Multisonde and EXO Link up and down.
Ground/vent plug	A ground wire connects here and hangs into the water under the T-Frame as far as possible from the Multisonde cable to prevent tangles.

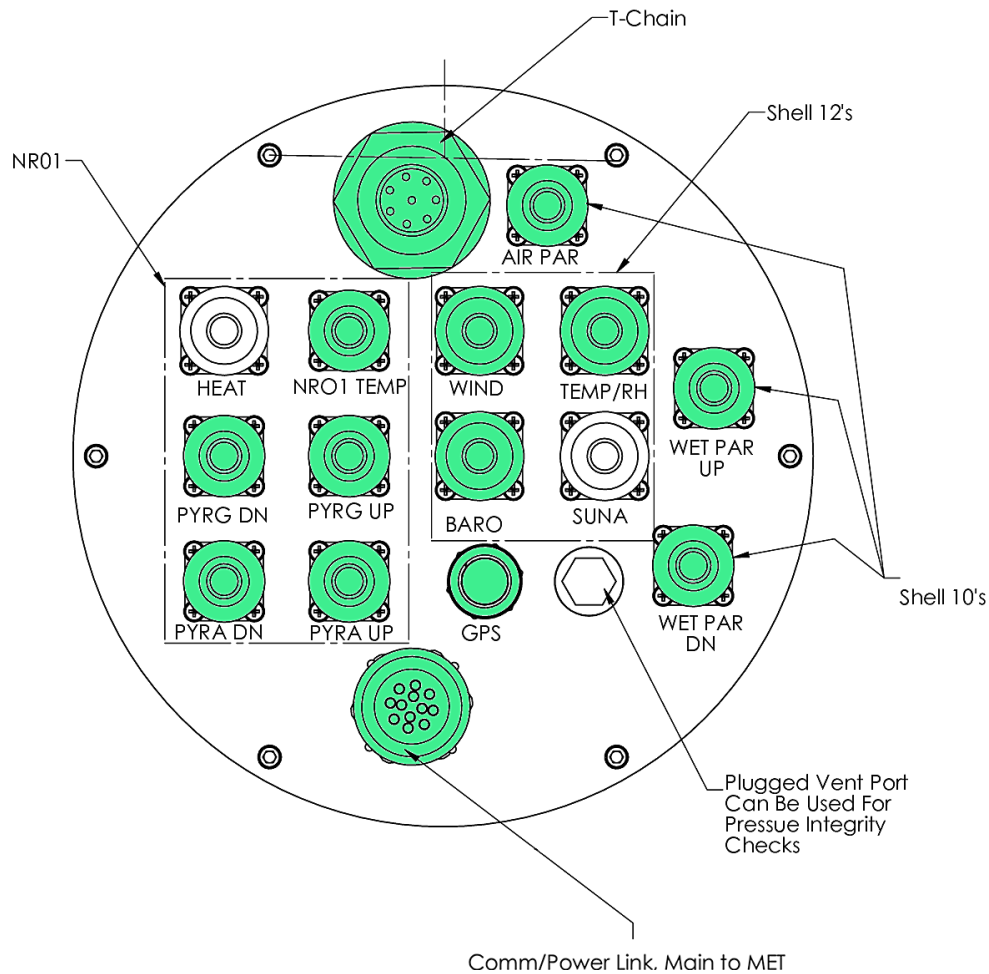

Figure 16. MET Canister Port Mapping

Use Table 4 with Figure 16 to clarify the port naming convention on the Profiler Canister.

Table 4. YSI Met Station Port Mapping for MET Canister Decoded

Figure 16. MET Canister Port Mapping

T-Chain	T-Chain power/data connection (these are data ports that provide power to the sensor).
AIR PAR	PAR/PQS1 data connection.
NR01 HEAT	NR01 – digital connector and is larger than the other 5 connectors.
NR01 TEMP	NR01 – this should have a label onsite – maintain label.
PYRG DN	NR01 – this should have a label onsite – maintain label.
PYRG UP	NR01 – this should have a label onsite – maintain label.
PYRA DN	NR01 – this should have a label onsite – maintain label.
PYRA UP	NR01 – this should have a label onsite – maintain label.
WIND	RM Young Wind Vane sensor data connection.
TEMP/RH	Vaisala HMP-155 power/data connection.
BARO	Vaisala Barometric Pressure sensor power/data connection.
SUNA	Not in use – The NEON project uses a different setup to transmit SUNA data.
GPS	Garmin GPS on T-Frame data/power connection.



Figure 16. MET Canister Port Mapping

WET PAR UP	Up-facing/Downwelling PAR, which faces UP (the white diffuser faces the lake/river surface water and cable faces the river/lakebed).
WET PAR DN	Down-facing/Upwelling PAR, which faces DOWN (the white diffuser faces the lake or riverbed and cable faces the surface).
Comm/Power link, Main to MET	Profiler PVC Canister connects to MET PVC Canister.

6. Inspect the two Battery Enclosures within the T-frame. Ensure posts are corrosion-free and that connections are secure.
 - a. Verify voltage capacity: > 12 volts; < 11 volts and the system shuts down.
 - b. Use a Digital Multi-Meter (DMM) to check voltage (see **Figure 17**).
 - i. Set the DMM for Volts DC (direct current).
 - ii. Red goes to positive +
 - iii. Black goes to negative –
 - c. The charging light on the charge controller(s) illuminates at least some of the time (it will turn off when the battery is fully charged). **Figure 17** displays the charging light lit up, which means the battery is charging.
 - d. The Activated light is off (A lit up Activated light means the battery is low and the buoy electronics are off). **Figure 17** displays the location of the Activated light.
7. Inspect solar panels. Ensure all mounts are secure: mounting to the deck and the T-Frame cover. Wipe away dirt and debris. Ensure connections are secure to their respective charge controllers.

 *Note: The solar panels must receive direct sunlight. If the panels are no longer receiving direct sunlight due to the orientation of the buoy or panels, please submit a ticket to the NEON Issue Management/Reporting System for headquarters to evaluate and remediate.*

- a. The solar panels on T-Frame cover are facing west and east.
 - b. The auxiliary solar panels on the deck face south.
8. Inspect Met Mast. Ensure it securely attaches to the T-frame via three U-bolts. Tighten or replace loose nuts, bolts, washers, as applicable.
 - a. Ensure it securely attaches to the floating deck via three Guy-wires.
 - b. Replace zip-ties, as appropriate.
 - c. Note: the three Guy-wires are tight, but low in tension. This is more for stabilization than for tensioning. Using a crescent wrench, loosen the jam nut and retighten turnbuckle to tighten

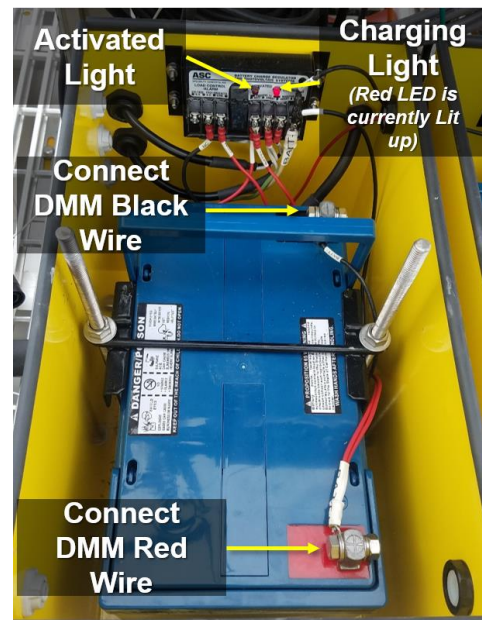



Figure 17. AIS Buoy Battery Box/Enclosure and Battery (Where to Connect DMM)



Title: NEON Preventive Maintenance Procedure: AIS Buoy		Date: 03/08/2022
NEON Doc. #: NEON.DOC.004613	Author: M. Cavileer, G. Simonds, R. Willingham	Revision: C

enough to stabilize the Met Mast evenly across each wire. If you tighten it to the point of pulling the mast out of level, then it is too tight.

 **Note:** **DO NOT** remove the U-bolts that attach the mast to the T-Frame. The mast can easily tip. When removing the mast for servicing instrumentation, undress the cables and disconnect them from the sensors, remove applicable sensor instrumentation, release the guy-wires, loosen the U-bolts, and slide the mast up. Do not remove the Met Mast while on water.

- d. Inspect the radiation sensor mounts securely to the mast via two U-bolts, flat washers, lock washers, and ½” nuts. Use the battery box as step up to reach the Radiation boom arm mount. Loosen the two U-bolts (never remove) to swing the radiation boom arm in/lower for servicing.
- e. Cut and replace zip ties, as appropriate.
- f. Use a Boomtron to reach the radiation sensor for cleaning.

 **Note:** The radiation boom arm must orient south $\pm 45^\circ$ and be perpendicular (90°) to the buoy.

- g. Check hose clamp attached to the mast (see **Figure 18**). This works as a bump stop above the boom. A bump stop enables reinstallation to a fixed height. This may or may not exist at all AIS Buoy sites. AIS Buoy sites are welcome to install one of their own to know where the fixture must stop on the Met Mast.



Figure 18. Bump Stop on Met Mast

 **Note:** The Met Mast points perpendicular to the buoy centerline, on the port side.

- h. Inspect SUNA radio antenna and radar reflector, which also mounts to the Mast (see **Figure 19**). The SUNA radio antenna should point towards the AIS Aquatics Portal.
- i. The RM Young Wind Monitor (2D Wind) is a mechanical wind sensor (comprises of mechanical components, such as bearings) as opposed to a sonic wind sensor (electronic data collection) at our Terrestrial Instrument Sites (TIS). Inspect the ceramic bearings for this instrument (ceramic bearings are resistant to corrosion; comprises of Teflon seals with low torque wide-temperature range grease).
- j. Two items to monitor for the RM Young Wind Monitor when conducting maintenance activities on the AIS Buoy:

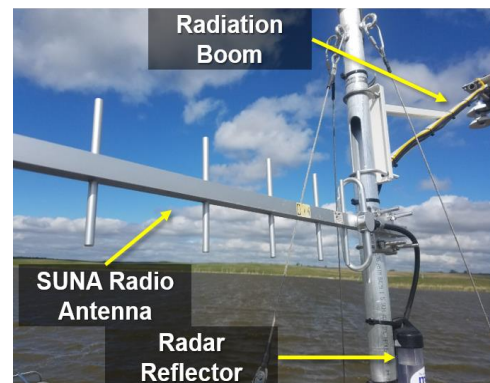



Figure 19. SUNA Radio Antenna and Radar Reflector on Met Mast



Title: NEON Preventive Maintenance Procedure: AIS Buoy		Date: 03/08/2022
NEON Doc. #: NEON.DOC.004613	Author: M. Cavileer, G. Simonds, R. Willingham	Revision: C

- i. If anemometer bearings become noisy or wind speed threshold increases above an acceptable level, bearings may require replacement. A rough check can be performed by adding an ordinary paper clip (0.5 gm) to the tip of a propeller blade. Turn the blade with the paper clip to the "three o'clock" or "nine o'clock" position and gently release it. Failure to rotate due to the weight of the paper clip indicates anemometer bearings need replacement. Repeat this test at different positions to check full bearing rotation.
 - ii. The potentiometer in the RM Young Wind Monitor has a life expectancy of fifty million revolutions. As it wears out, the element may begin to produce noisy signals or become nonlinear. When signal noise or non-linearity becomes unacceptable, replace the potentiometer.
9. Inspect dual PAR SUNA bracket and mount.
- a. Remove biofouling in the cage using water and a dry brush. Replace zip-ties, as appropriate. See *Section 6.2.2* for instructions on moving the mount.

 *Note: On most lakes and rivers, the yellow fiberglass housing that shields the electronic components is unable to open when the SUNA cage and arm is up and out of the water.*

- b. In the mount, ensure the SUNA brush does not hit the cage. The slot should be facing toward the bracket in order to allow maximum room for brush movement. The brush operates every 15 minutes to mitigate biofouling.
- c. For select sites using the assist for this mount, please ensure it is not degrading the integrity of the bracket.
 - a. Ensure the guy-wire jam nuts are tight after resetting the dual PAR SUNA mount in the water (see **Figure 21**). The jam nut enables the turnbuckle to be secure post-tightening. Tighten or replace loose nuts, bolts, washers, as applicable.

 *Note: The water may cause these jam nuts to loosen and/or fall off in the water, allowing the turnbuckle to fall off in the water. Figure 20 on the next page displays these components for reference.*



Figure 20. Guy-wire Components

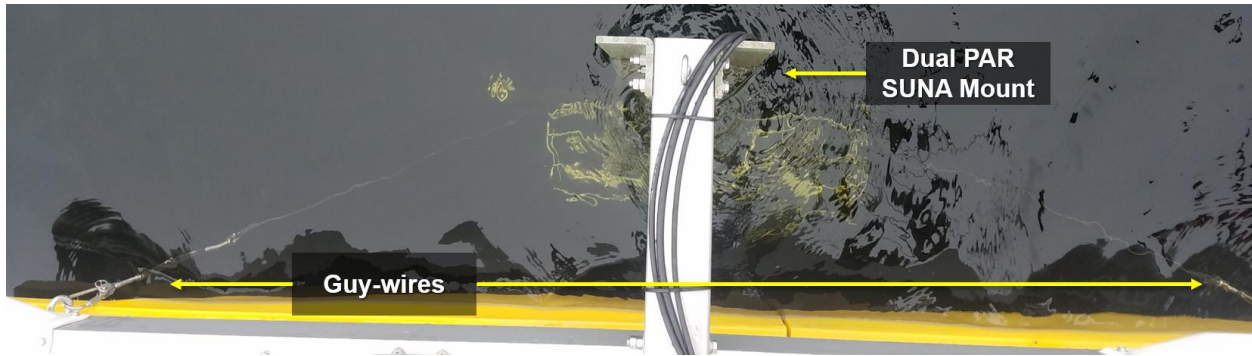

Figure 21. Looking Down on the Dual PAR SUNA Mount and Guy-wires

10. Inspect Depth Finder bracket (see **Figure 22**), pole and cable.



Figure 22. Depth Sounder Bracket (Left) and Depth Sounder Instrument (Right) on Floating Deck

11. Inspect the Temperature Chain (T-Chain) attachment to the floating deck (see **Figure 23**) on the bow. The T-Chain is a single-cable string consisting of sensors that measure water temperature at specific depths in Celsius. The T-Chain varies in length per AIS Buoy site.

- a. Try not to step on the T-Chain cable on the floating deck. If anything catches on the cable, verify it did not disengage the sensor from its power source.
- b. Ensure the attachment is secure and not tangled in the mooring lines. The T-Chain should never be under tension (e.g., not caught in the mooring lines or debris underwater).
- c. Verify the T-Chain is not accumulating floating debris (this may occur more frequently in AIS Buoy river locations).
- d. Inspect the T-Chain rope for UV damage.

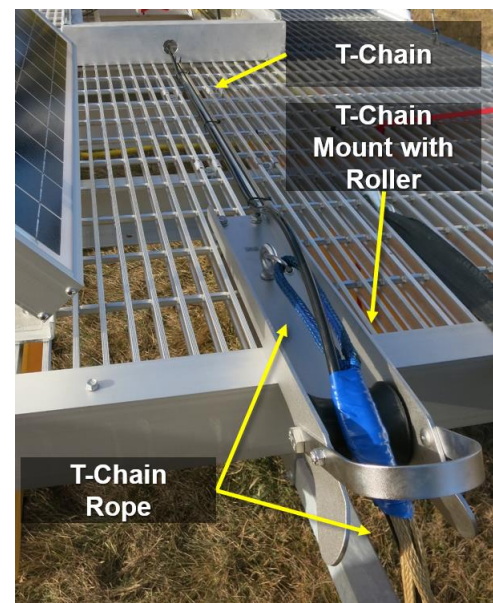

Figure 23. T-Chain and T-Chain Mount on Floating Deck



- e. Replace zip-ties, as appropriate. (Use heavy-duty zip ties for D03 FLNT AIS Buoy. **Table 1** lists the part number for heavy-duty zip ties.)
- f. For D03 FLNT: inspect T-Chain attachment under the T-Frame. This T-Chain is under tension with a small weight to attempt to maintain it linear through river currents. Reference **Figure 24**. In order to prevent the chain from dragging, the cable is coiled over a post on the T-Frame, which is clamped in place. The T-Chain attaches to the cable with heavy-duty zip ties (regular zip ties may disintegrate/loosen faster over time). This assembly requires adjustments as the river height changes to ensure it does not drag on the bottom of the riverbed.

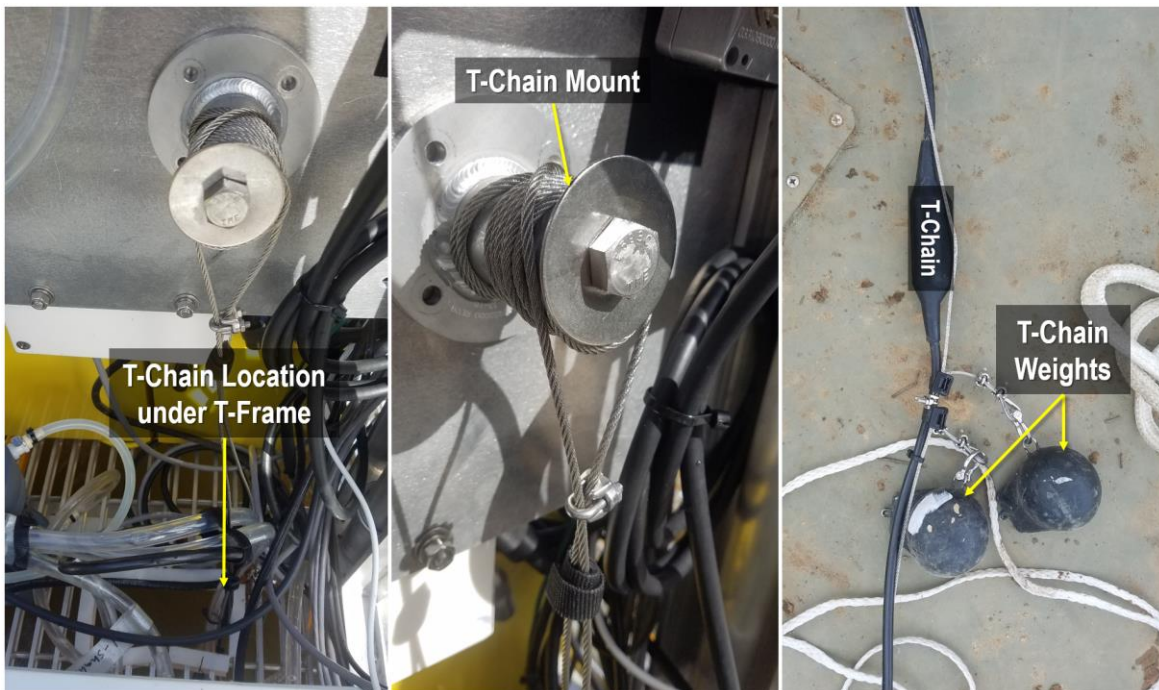

Figure 24. D03 FLNT ONLY: T-Chain Location, Mount and Weight

 See AD [05] for list of site-specific T-Chain depths from water surface.

- 12. For D03 FLNT: inspect the Multisonde and SUNA sensor fixed underwater tubes biweekly to ensure river debris is not catching and accumulating on or between the tubes. Either secure a large bottle or toilet brush on a boat hook or purchase an [extendable cleaning tool](#). Ensure the tubes are not hitting the river bottom. If the river level reduces below a meter, and continues to reduce or is projected to reduce below a meter, remove the two sensors and their tube mounts. Submit a ticket to notify NEON HQ for data quality and awareness. If Technicians are unsure if it is necessary to remove the sensors, submit a ticket to monitor the event with the support of AIS Science and/or Engineering departments. Reference Section 6.2.5 for more information.



5.3.3 Winch Assembly Maintenance

As stated above in *Section 5.3.2*, inspect the winch assembly that attaches to the AIS Buoy T-frame. (The winch assembly faces the bow.) This primarily includes the motor and motor gear, axle, drum, and winch belt (see **Figure 25**). This section aims to provide additional guidance for these tasks.

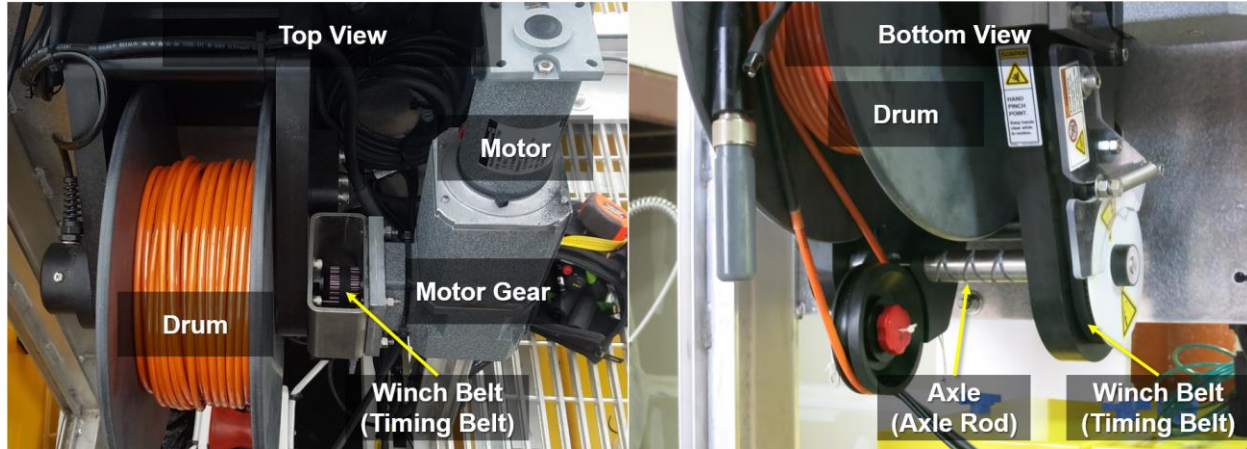

Figure 25. Winch Assembly Components

1. Tighten or replace loose nuts, bolts, washers, as applicable.
2. The winch axle (axle rod) requires lubrication with Krytox 205 annually. **Figure 26** is an example of a properly greased axle. Maintaining lubrication on this component ensures the equipment lifespan.

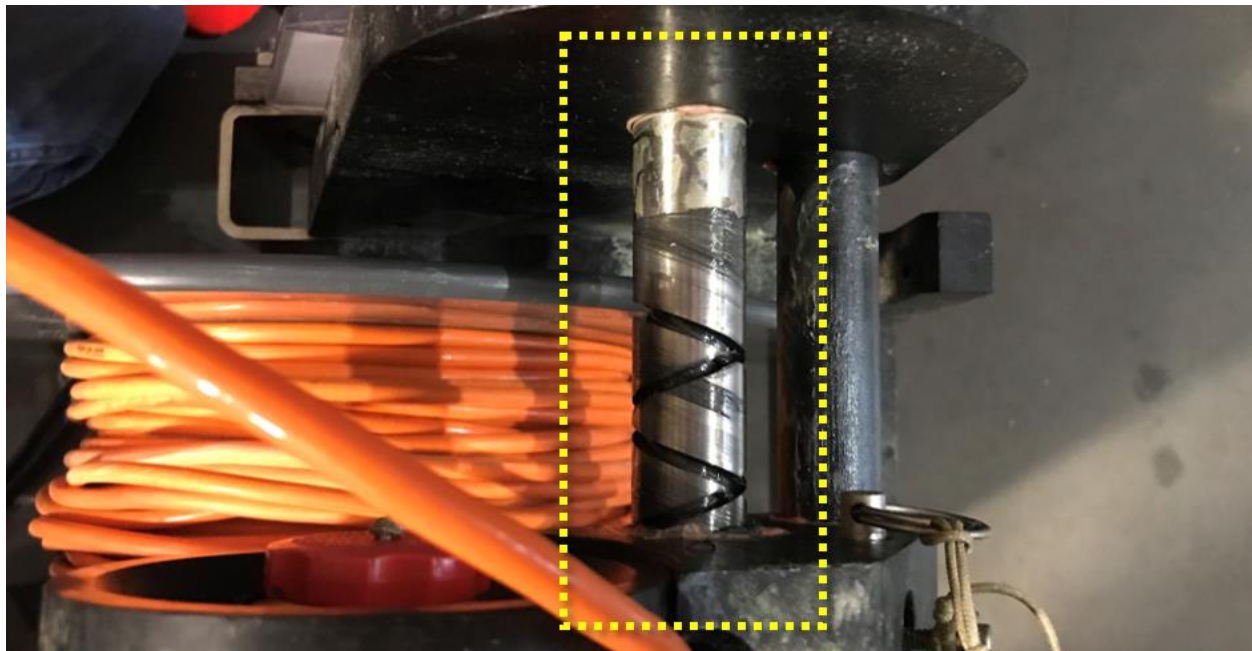

Figure 26. Properly Greased Winch Axle (Axle Rod)



The winch encompasses two safety thresholds. A mechanical safety mechanism and an electrical safety mechanism. For mechanical, the couplet break point has the lowest threshold and YSI provides spares with each AIS Buoy. For electrical, 4.2 amps shuts off the motor.

5.3.4 D03 FLNT ONLY: Peristaltic Pump Maintenance

Peristaltic pumps, also known as tubing pumps (the tube is the pump), are a type of positive displacement pump. The motion is peristalsis (e.g., the esophagus in the body). A peristaltic pump features a unique design — a drive system turns a set of rollers, which compress and release flexible tubing as they rotate. This squeezing action creates a vacuum that draws fluid through the tubing. Fluid contacts only the flexible tubing; creating a contamination-free pump system that is easy to clean and maintain.

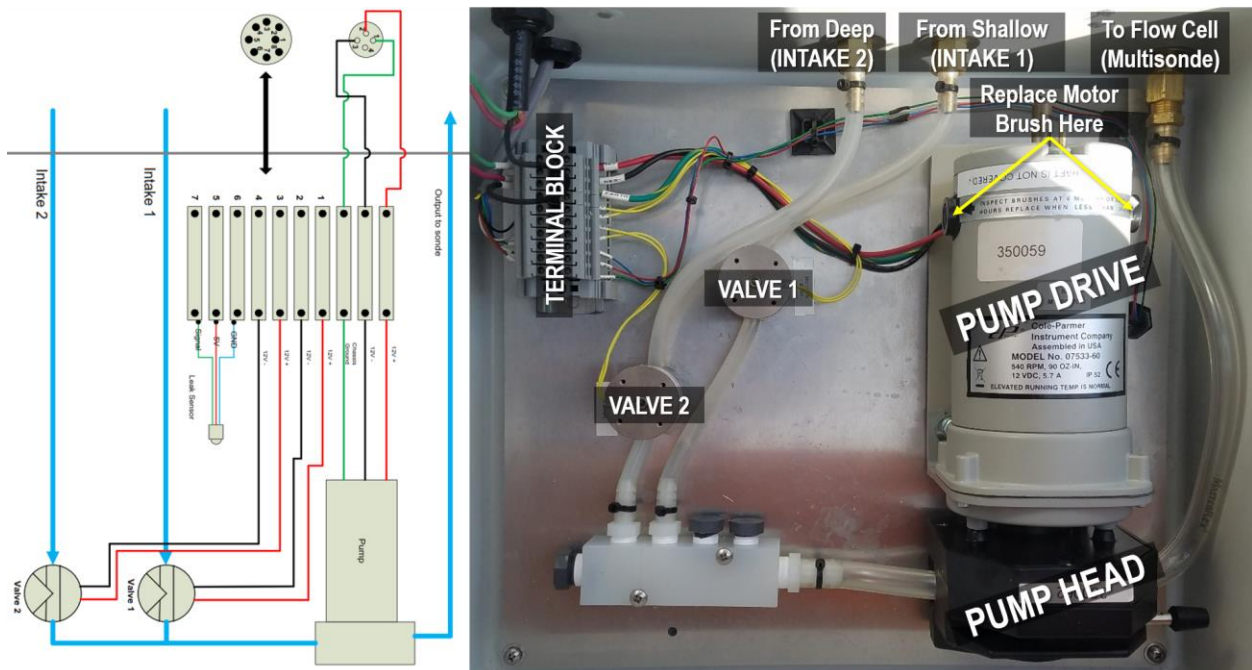



Figure 27. D03 FLNT: Peristaltic Pump Schematic (Source: YSI) & Enclosure Components

Maintenance is minimal for these types of pumps. The primary wearing component is the tubing; however, certain tubes may maintain up to ten thousand hours of life under certain conditions, which is several years run time. Conduct a visual inspection on the system to check the condition of the tubes and ensure water is not accumulating in the enclosure. The system comes with a water sensor; to access the water sensor, log onto LoggerNet. Remove biofouling/debris accumulating around the pump system tubing in the river.



Figure 28. D03 FLNT: Pump Tubing pulled from the River

 **Note:** An overflow hose for the Multisonde (Flow Sonde) Flow Cell drains below deck. In order to drain overflow, the hose must be above water. If the hose is under water, it sucks water into the pump when the pump reverses to empty the Flow Cell. The overflow tube his held to the deck via zip tie(s). Inspect to ensure the overflow hose is not underwater during biweekly PM visits.

The pump drive requires minor maintenance every six months. Turn off power to maintenance (reference AD [13] to remove the power input cable for the pump profiler canister or see **Figure 54** on page 56. Access the pump enclosure on the opposite site of the T-Frame from the canisters. Replace motor brushes after 6 months or when the length wears to approximately 9.53 mm (0.375 in.) (07533-01, Motor Brushes, set of two).ⁱⁱ Use **Figure 27** and **Figure 55** for component locations. A label on the pump identifies the brush locations that require replacement.

 **PRO TIP:** Recommend using a flathead bit from the 11-in-1 by itself to remove the brush closest to the housing wall. It is kind of a tight fit, but it works.

5.3.5 Adjusting the Mooring System

Fresh water lakes and rivers naturally adjust over time. Water levels dropping/rising may strain the mooring system of the AIS Buoy. To ensure the lifespan of the mooring system, and prevent unnecessary strain on the buoy and mooring lines, use the following procedure to adjust the mooring lines to accommodate water level changes at your site.

13. Ensure the mooring lines do not move ± 45 degrees. If water level drops, the lines are loose and FOPS needs to remove slack in the line. If water rises, the lines get tight and FOPs need to add slack.
 - a. **To add slack:** While standing on buoy, pull in one anchor line to find the sheepshank containing excess line. Remove enough extra line to allow for water depth increase. Retie sheepshank and secure with cord/twine.
 - b. **To remove slack:** While standing on the buoy, pull in one anchor rope until line is as tight as desired. Tie excess line into a sheepshank and secure with cord/twine. Then do the same to the



Title: NEON Preventive Maintenance Procedure: AIS Buoy		Date: 03/08/2022
NEON Doc. #: NEON.DOC.004613	Author: M. Cavileer, G. Simonds, R. Willingham	Revision: C

other anchor rope. Ideally, the buoy will sit equidistant between the two line floats, but some adjustment may occur to move closer to the site-specific GPS location (this resides in the site as-built document).

- c. **To adjust anchors in river locations:** Use a boat and travel to front/back anchor. Pull the anchor from the rope. Use a boat hook to grab the rope as far as you can reach to leverage slack in the line to pull the anchor out of the substrate to reset it. Submit a ticket in the NEON Issue Management and Reporting System if unable to reset the anchors due to unforeseen/unanticipated issues.

 **Note:** *YSI expects the mooring system to last up to five years, depending on fresh water lake variables (e.g., fetch, wind, UV, and if any existing objects interfere with the mooring system). If an anchor fails, it is likely to display remotely from rotating GPS coordinates (the AIS Buoy would rotate like a clock if a failure occurs on one point of a two-point mooring system). If there are any concerns regarding your mooring system underwater (chains/anchors and other components not visible for maintenance inspections), please submit a ticket to NEON HQ via the Issue Management and Reporting system. NEON HQ will evaluate the ticket and determine if a diver must deploy to inspect and/or conduct corrective action on the system.*

5.3.6 Seasonal Removal/Towing, Storage and Redeployment

5.3.6.1 Winter Removal/Towing

Per NEON.AIS.4.1314, aquatic-based sensor infrastructure shall be removed from select lake and wadeable stream sites prior to ice formation that could result in structural damage. Remove the AIS Buoy when the weather projections are calling for any ice accumulation or severe weather conditions.² The buoy is able to handle a light snowfall; heavy snowfall increases the risk of the buoy tipping over. Conduct the following procedure to prepare the AIS Buoy for removal from the lake to tow to your site-specific storage location. **All submerged sensors must be out of the water before removing the buoy from its mooring.**

1. Decontaminate the Trailer prior to site access. Use the procedure in AD [08] for field vehicles. Ensure it meets the height and width requirements of the buoy without the Met Mast. YSI pontoons are narrower than the standard pontoon. To meet buoy specifications, modify the trailer, as follows:
 - a. Relocate the mounting brackets to match the width of the pontoon. Leave the rear and center mounting brackets as-is. Move the front bracket forward to meet the trailer frame (see **Figure**

² YSI, Inc. About the Vertical Profiler Frequently Asked Questions (FAQs). "Can I leave my system out year round? Unless you have ice or extremely severe storms and weather conditions, your system can be continuously deployed and maintained." <https://www.ysi.com/File%20Library/Documents/FAQs/Vertical-Profiler-FAQs.pdf>



- 29). Adjust the ladder/ buoy bumper backwards towards the pontoon float rack by loosening and sliding the U-bolts. Lower the winch to match the buoy height.
- b. “Buoy dimensions are just shy of 7 x 13 ft.” (Scott, 2017).



Figure 29. Mounting the AIS Buoy on the Trailer

2. Deploy a boat and necessary tools per Table 1 to prepare the AIS Buoy for transport/towing to land.
3. Use the boat deck cleats to cinch the buoy alongside the boat, using bumpers (or spare life jackets) to protect the boat and the buoy (**Figure 30**). For lake sites, use both tie off points in **Figure 30**. For river sites, use only one tie off point. This enables a faster release to quickly respond to a Technician that falls into the river current fully dressed.

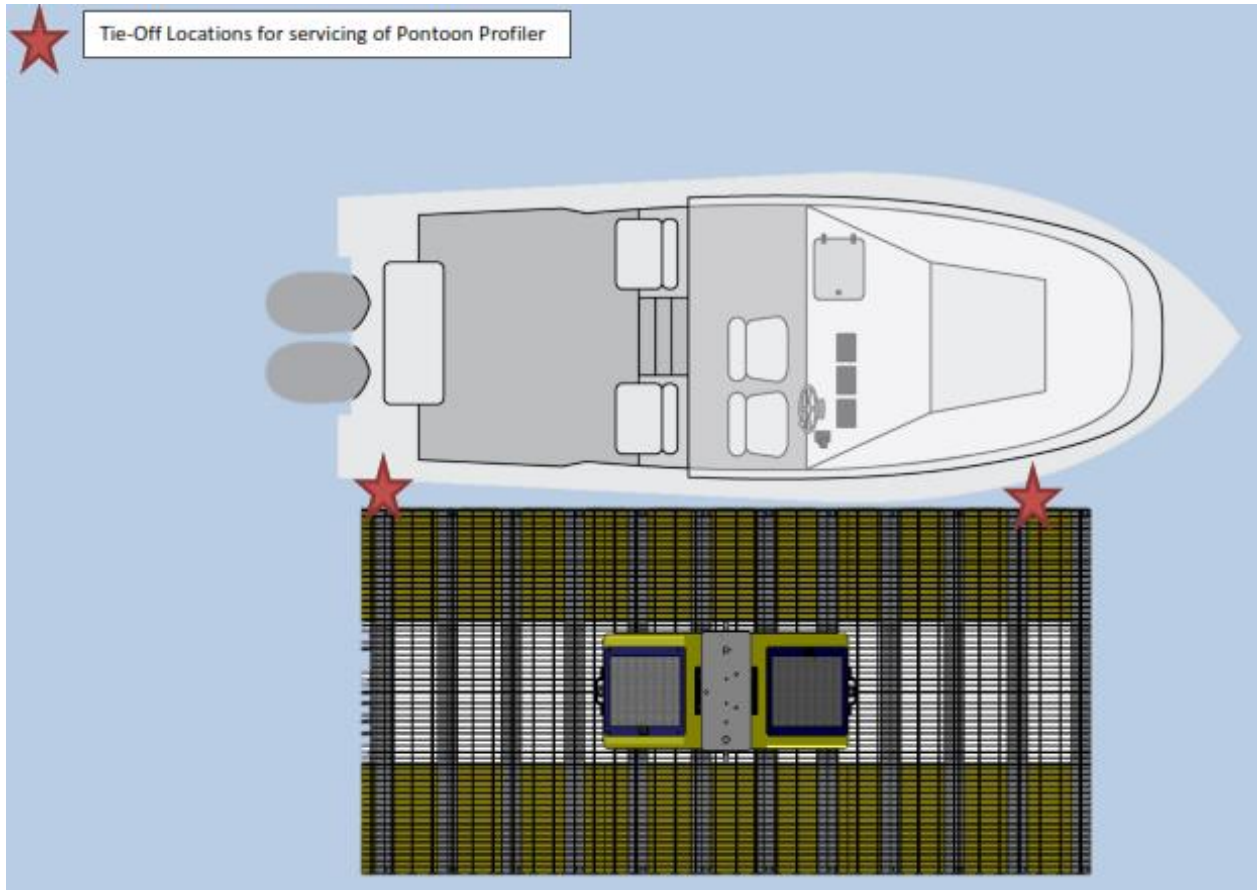

Figure 30. Tie-off Points for Servicing the AIS Buoy for Lakes (Use Only 1 Tie-off Point for River Sites)

4. Place the buoy in setup mode. Turn Flag 2 on (high). Flags are a default term in the profiler software; you are requesting the system to start or stop an action by turning a Flag on (high) or off (low).
5. Bring all underwater sensors above water. This includes the Multisonde with EXO Link, PAR, SUNA, T-Chain, Depth Sounder and pole.
 - a. Carefully pull up the T-Chain and lay it on the deck. Zip-tie removal may occur while docked or onshore.
 - b. For the Depth Sounder, use a $\frac{3}{4}$ " ratchet wrench to remove the two bolts and nuts hardware. Place the hardware in a secure place or reinstall in Depth Sounder arm to prevent losing any part. Place the arm on the deck for transportation.
 - c. Pull up the winch, but leave some slack. Remove the EXO Link and Multisonde. For the Multisonde, see *Section 6.2.1 Profiler Multisonde Removal and Replacement*.
 - d. The winch connector to the Multisonde is NOT waterproof. Install the cover in red in **Figure 31**.



Figure 31. Protect Winch Cable from Water



6. For D03 FLNT: The Depth Sounder and Multisonde/Winch Assembly removal is not applicable.
7. Pull up the Dual PAR SUNA Mount. Disconnect the two locking carabineers from the eyebolts on the side of the buoy stabilizing the mount underwater and reference *Section 6.2.5* to pull up the mount.
8. Secure the Dual PAR SUNA Mount for towing by tightening the two guy-wires when the mount is upright on the floating deck (see **Figure 32**). Tighten guy-wires for stability: *tight, but low in tension*.

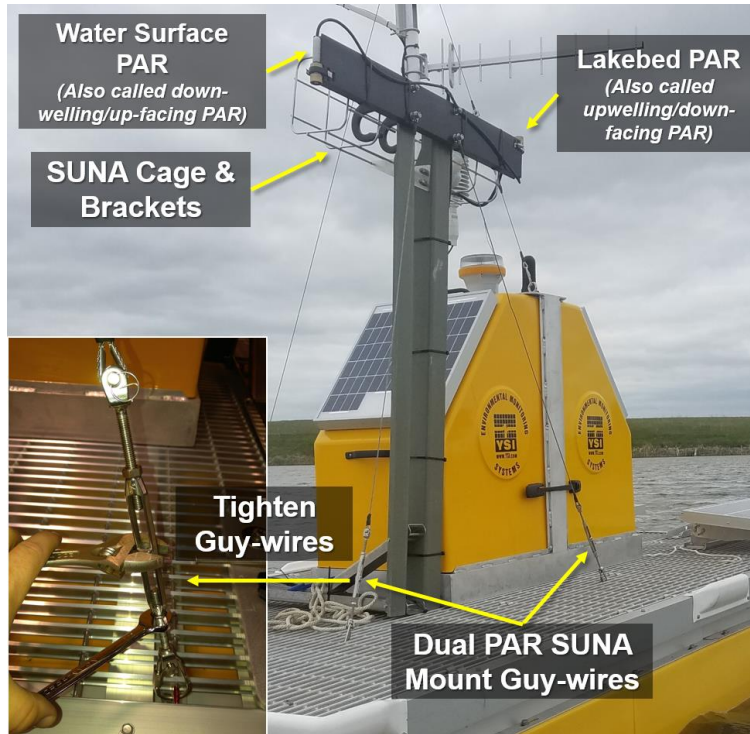

Figure 32. Dual PAR SUNA Mount in an Upright Position with Guy-wires for Transport

- a. Using a combo wrench, loosen the jam nuts and tighten the turnbuckle.
- b. Retighten the jam nuts after tightening the turnbuckles (see **Figure 32**).
9. For D03 FLNT: Bring the retractable uPAR mounting system above water and flatten the assembly on the deck using the six slide locks. Two slide locks bring the extendable arm with uPAR amount above water (reference **Figure 70**). Four slide locks enable the mounting system to lay flat on the deck for towing (one on each side and two at the base in **Figure 33**).

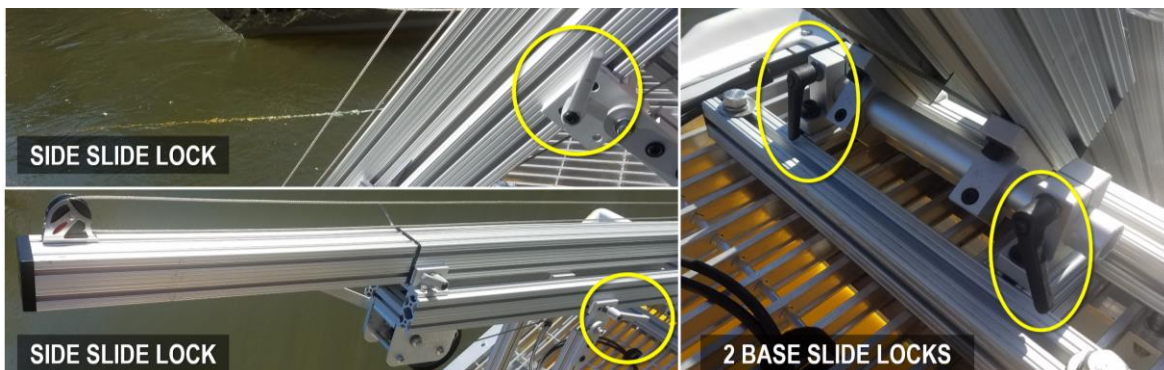





Figure 33. D03 FLNT ONLY: Four Slide Locks to Flatten Retractable PAR Mounting System for Transportation

This enables the retractable PAR mounting system to lay flat on the deck (Figure 34). Secure the assembly by locking the same four slide locks when the assembly is flat on the deck.



Figure 34. D03 FLNT ONLY: Retractable PAR Mounting System Flat on Deck for Transport

 **PRO TIP:** One PAR faces the water surface and the other PAR faces the lakebed. They sit at each end of the Dual PAR SUNA Mount. Use electrical tape to differentiate between the two to aid reinstallation. Ensure the yellow dot aligns with the raised nub when reattaching cables to the water surface and lakebed PARs.

10. For D03 FLNT: Remove the Multisonde and SUNA sensors from the fixed underwater tubes and bring each tube above water. Place the sensors and tubes securely on the Buoy deck or in the Domain's boat for transport to shore. *Reference Section 6.2.5 D03 FLINT ONLY: Multisonde and SUNA Sensor Removal and Replacement for Fixed Underwater Tube Mounts.*
11. Remove the shackles connecting to the bridles to the anchor.
 - a. Pull the nearest anchor end/line float shackles into the boat.
 - b. Use pliers to remove the cotter pin. Employ care to prevent dropping the cotter pin the water.
 - c. Use channel locks and/or a pipe wrench to remove the shackle connecting the bridle to the anchor/line floats (see Figure 35). Leave the bridles attached to the buoy for towing. **DO NOT DISCONNECT THE LINE FLOAT FROM THE ANCHOR LINE! Only remove the bridle from line float and anchor line.**



Figure 35. Remove Cotter Pin and Shackle Connecting Bridles to Line Float/Anchor Line

12. Secure the buoy mooring system that remains in the lake. Employ Option 1 or Option 2 below, as applicable to site characteristics. A combination of both options is OK, too. This prevents having to search the lake for floats or dig the mooring system lines out of a mucky lake bottom.
 - a. **Option 1:** After removing the buoy from the mooring, attach weighted line to each anchor shackle. Remove the line float from the anchor shackle and run the weighted line to shore. Be careful not to entangle the two anchor lines.
 - b. **Option 2:** Remove the surface water line floats. Leave the mid-water line floats in place.
 - c. **For sites with trip lines:** Attach a weighted line to each trip line and stake the line to shore.
 - i. Remove the line float and replace with weighted line, and run the line to shore. Again, be cognizant of the lines to prevent snares.
 - ii. Secure all shorelines to shore by leveraging a nearby sturdy object (e.g., tree) or pound in a post to secure the lines.
 - iii. If adding any infrastructure, the Domain Manager/NEON Permitting office must coordinate this action with the site host to ensure this is OK. If issues arise, submit a ticket for HQ evaluation.
 - d. **For temporary removal:** leave the line floats in place with the anchor lines.
 - e. **For TOOK:** Use the shallow area to the west of the buoy location to secure the shorelines (sturdy object underwater). For long-term removal, the Conex was used in the past.
 - f. **For PRLA, PRPO, CRAM, and LIRO:** Employ option 1 or option 2 or a combination of both, as applicable, at the discretion of the Domain Manager. If the lake level drops during the winter or freezes to the point of the mid-line floats, causing the mid-line float to catch in the surface freeze, then employ Option 2. *Ice can move the buoy mooring system in the lake and marine growth/biofouling can disguise the mid-line floats in the spring when attempting to relocate them.*
 - g. **For SUGG, BARC, TOMB, BLWA, and FLNT:** Seasonal winter removal/spring deployment requirements do not apply to these two buoy sites. Employ temporary removal requirements, as applicable. Specifically for TOMB and BLWA, removal of the AIS Buoy requires notification and coordination with the USCG ahead of time.



13. Tow the AIS Buoy to land and stage offshore or on dry ground to continue the remainder of the procedure. **Only tow the buoy by the bridle or the bridle eyebolts on the floating deck.**
- a. **Figure 37** provides an example for towing the AIS Buoy to maintain the most control over it on the water. Other methods have proven tedious due to the weight of the buoy compared to our boats. **Do NOT tow the buoy by the buoy deck cleats (Figure 36 shows a deck cleat).**
 - b. **The configuration shown in Figure 34 prevents the buoy from becoming uncontrollable in high currents and winds.**



Figure 36. DO NOT USE CLEATS

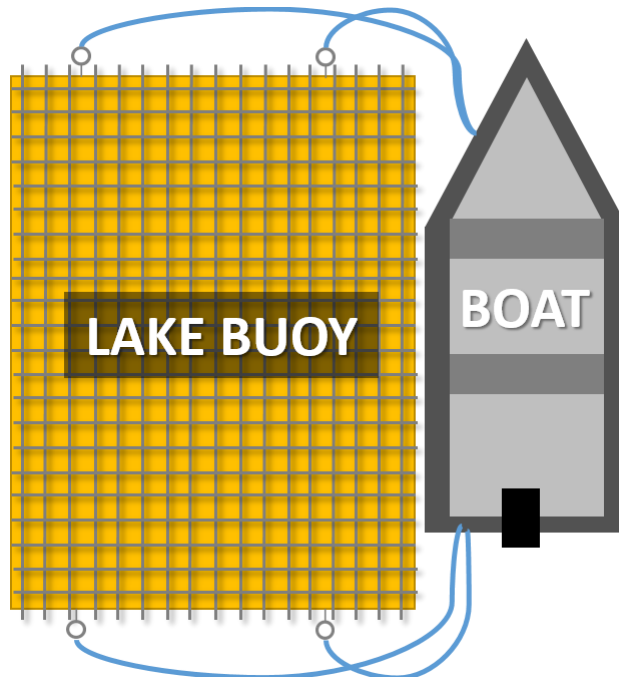

Figure 37. Recommended Towing Technique

14. Remove the bridle from the eyebolts before transporting the AIS Buoy out of water. The aluminum brackets are easily bent.
15. Power down the AIS Buoy. Conduct each of the following steps in sequence.
- a. Disconnect the Power Input cord from the winch or pump profiler canister. (The Canister below the MET Canister on the T-Frame.)
 - b. Disconnect the solar panels (two or four solar panels may exist depending on site-specific requirements).



- c. Disconnect the battery directly in the battery enclosure (see **Figure 38**). Disconnect the negative lead (black wire) first then disconnect the positive lead (red wire). Remove the bolt using a ½” open-end wrench to detach the batteries from the solar regulators. Do this for each battery (some sites use more than one). For Technician awareness, two protective yellow 8-amp fuses exist for each battery to prevent the battery from receiving an overabundance of electrical current.
- d. Disconnect Sensor and Subsystem connections from each PVC Canister and cap all ports.
16. Secure the Multisonde assembly from the AIS Buoy or Boat (from temporary “above water” placement during AIS Buoy transport to a dock/shore). *See Section 6.2.1 Profiler Multisonde Removal and Replacement and Table 9. AIS Buoy Sensor Packaging Requirements.*
17. Remove the T-Chain.
 - a. Cut the zip-ties securing it to the floating deck and unlock the small locking carabineer that connects the Yale Grip rope to the eyebolt just behind the roller.
 - b. For D03 FLNT: Cut any zip ties and remove the T-Chain from the mount on the T-Frame.
18. Remove the SUNA and the two PARs from their respective brackets.
 - a. Disconnect the SUNA power cable that connects to the Radio Box.
 - b. The SUNA pops out of three black clamps within the cage with some force applied. The SUNA has its own radio provided by NEON, not YSI. It attaches to the deck, below the winch in T-Frame. The power cable connects to the yellow battery box/enclosure. *Reference Section 6.2.3 SUNA and uPAR Removal and Replacement for Dual PAR SUNA Mount.*
 - c. Remove the two PARs from their rubber protected pipe clamp. Place black plastic caps at the optical end of the sensor. *Reference Section 6.2.3 SUNA and uPAR Removal and Replacement for Dual PAR SUNA Mount.*
19. Remove the Met and Profiler Canisters.
 - a. If not complete, disconnect connections on both canisters. Ensure each connection has a cap.
 - b. Each canister secures to the T-Frame via two large hose clamps. Use a flathead screwdriver to disconnect each hose clamp and maneuver the canister free from their grip. *See Section 6.2.6 Profiler and MET Canister Removal and Replacement* for the location of these hose clamps.
20. Remove the Barometric Sensor (Vaisala Barometer) from the T-Frame. Use a 7/16 ratchet wrench.
21. Remove the SUNA Radio Box that mounts to the deck for most locations and T-Frame for D03 FLNT. (Removal is optional for Domains with an

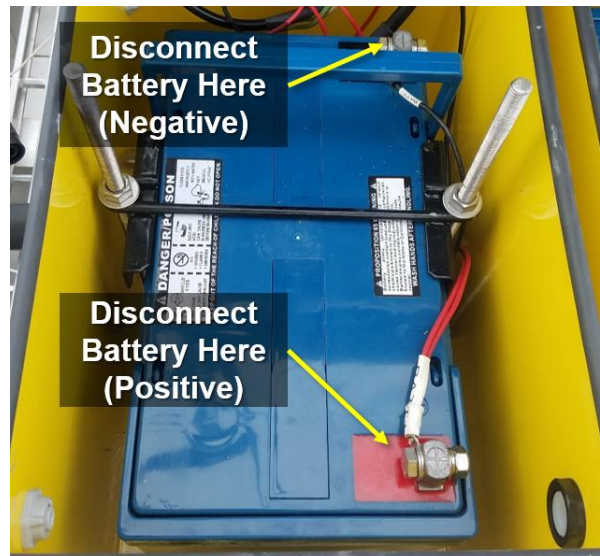

Figure 38. Disconnect the Batteries to Remove from the Battery Enclosure



- environmentally controlled storage unit for winterization. This is part of the AIS Buoy electronics; it is not necessary to remove this component for temporary situations in D03 and D08.)
22. Remove the Beacon from the buoy by removing the three hex bolts with 7/16" nuts that secure it to the T-frame. Use a 3/16 Allen Wrench to remove it from the T-Frame.
 23. Leave the Garmin GPS system on the buoy if storage conditions are above -40°C. (Removal is optional for Domains with an environmentally controlled storage unit for winterization.) Use an 11-in-1 to remove the GPS.
 24. Leave the Antenna on the buoy on the buoy if storage conditions are above -40°C. (Removal is optional for Domains with an environmentally controlled storage unit for winterization.) Use a 9/64 Allen Wrench.
 - a. Pull the Antenna cable up and through the T-Frame hole to prevent the cable from binding. **Do not disconnect cable from base of Antenna.**
 - b. For D08 TOMB: This antenna installation varies due to the AIS Buoy's distance from shore. *Additional instructions to be incorporated in next update version of this procedure.*
 25. Remove the Radiation Boom from the Met Mast (**Figure 39**).
 - a. Disconnect the cables to the sensors, if not already complete, and cut the zip ties.
 - b. Remove via the two U-bolts securing the boom arm to the Met Mast. Reference **Figure 39**.
 - c. Remove the PAR (PQS1) sensor using an allen wrench or flathead screwdriver.
 - d. Remove the NR01 sensor by removing the two allen setscrews on the underside of the sensor that adjusts for roll when leveling.

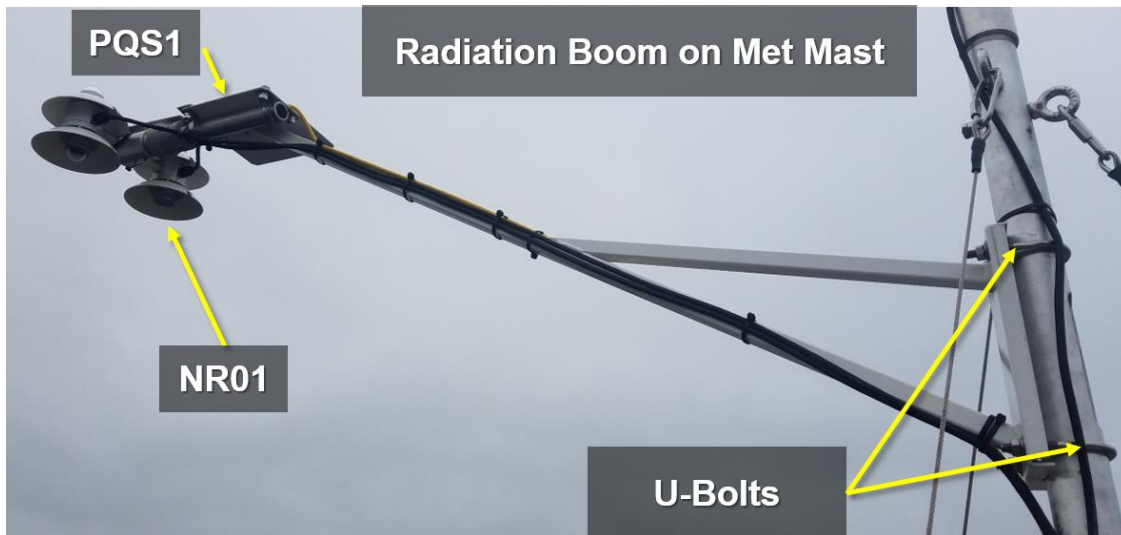



Figure 39. Radiation Boom Mount U-bolt Location

26. Remove the Humidity sensor (HMP155) and Radio Antenna. Reference **Figure 40**.
 - a. Disconnect cables and cut zip ties.



- b. Remove or loosen U-bolts mounting each component using a ½” ratchet wrench.
- 27. The radar reflector may remain on the Mast or Technicians may remove it by cutting the zip ties (**Figure 40**). NEON HQ recommends removing this component if the AIS Buoy seasonal storage location has minimal physical security measures in place (to prevent theft/tampering/vandalism).
- 28. Remove the Met Mast from the T-Frame. **Do not transport the AIS Buoy on ground with the Mast installed.**
 - a. Undress the cables and release the guy-wires via their locking carabineers from the floating deck. Loosen the jam nuts on the turnbuckles using a ½-ratchet wrench. For Technician awareness, one jam nut/turnbuckle is left hand threads – both sides rotate the same direction to loosen.
 - b. **Loosen the U-bolts** using a 9/16” wrench and slide the Met Mast up and over the U-bolts.

 **Note: DO NOT remove the U-bolts that attach the Met Mast to the T-Frame. The Met Mast easily tips over.**

- 29. Remove the RM Young Wind Monitor (2D Wind), last, after removing the Met Mast from the AIS Buoy.
 - a. Remove only the upper stainless steel band clamp.
 - b. Leave the lower location collar (lower stainless steel band clamp). The lower collar maintains the orientation for redeploying the RM Young on the MET Mast (similar to the bump stop) without loss of wind direction reference. See **Figure 41** for upper and lower collar location on Met Mast.

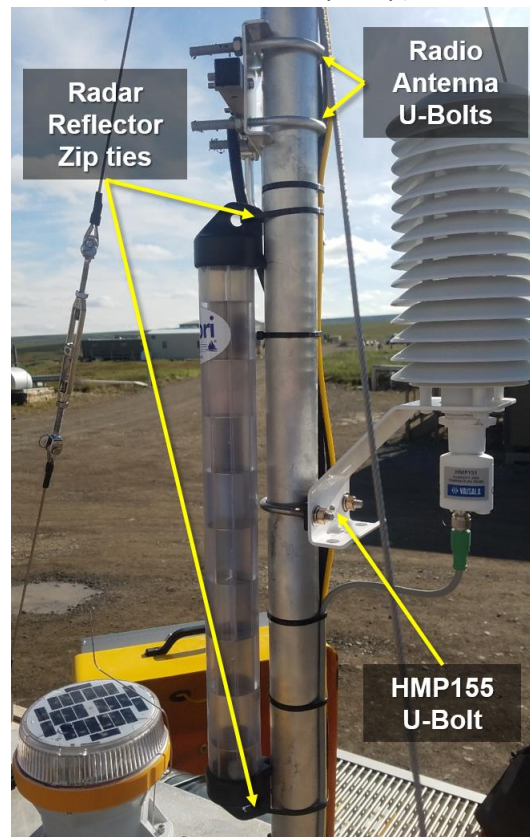

Figure 40. Remove Instruments from Met Mast



Figure 41. RM Young Wind Monitor (2D Wind) Upper and Lower Collar on Met Mast

30. For ground transportation purposes, the lay the deck solar panels flat using a ½” ratchet wrench (for sites that have the two auxiliary solar panels mounting to the floating deck).
 - a. Deck solar panels attach to a bracket via four hex bolts, eight flat washers, four split lock washers, and four 1/2” nuts.
 - b. The solar panels may remain on the AIS Buoy if the storage location contains physical security measures to prevent theft/tampering and/or vandalism.
31. Remove each battery.
 - a. Remove the two nuts securing the clamp in place to hold the batteries in their yellow/white box.
 - b. Two ½” wrenches or 1 ½” wrench and a crescent wrench are required to loosen hardware and remove positive/negative connections. Component hardware may remain in the yellow/white battery box for storage.
32. Remove each Charge Controller. (Removal is optional for Domains with an environmentally controlled storage unit or temporary removal situations in D03 and D08.)
 - a. Disconnect connections that feed through to both yellow battery boxes.
 - b. 11/32 socket wrench and smaller Phillips screwdriver.
33. Domains may remove the dual SUNA PAR mount for storage purposes. This is an optional step and dependent on space requirements.
 - a. Use a flathead screwdriver and magnet to remove e-clip from pin (**Figure 42**).
 - b. A magnet prevents the e-clip from catapulting into the surrounding body of water. Be mindful of washers. Return the pin and the e-clip to its original location on the Buoy platform to avoid losing any hardware components in storage.

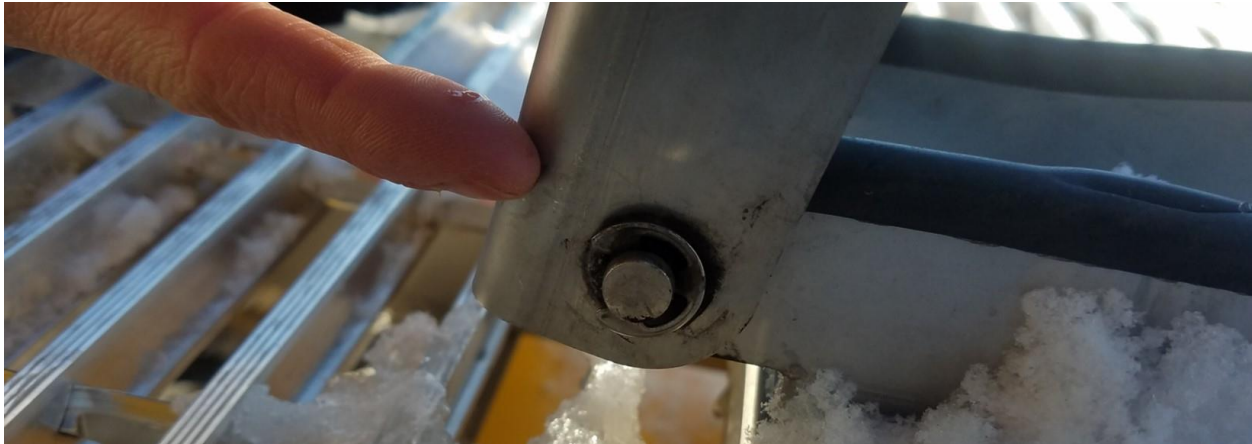

Figure 42. Dual SUNA PAR Mount E-Clip

34. Use a trailer or forklift (or equivalent equipment) with long, narrow tines, if available, to lift the buoy between the pontoon floats. FOPs may use other lifting techniques or alternative equipment to transfer the AIS Buoy from or into the lake/river for storage or redeployment. **Figure 43** is a site-specific example of removing the AIS Buoy from Toolik Lake in D18 for winterization.



Figure 43. Removing the AIS Buoy from Toolik Lake (TOOL) in D18 for Winterization

35. Arrange the buoy on the trailer in and out of the lake/storage location, unless it never leaves the trailer. **NEVER LIFT FROM THE CLEATS.** The deck frame bends and bolts may dislodge, if lifting from cleats. *Address site-specific issues and additional guidance pertaining to this step using the NEON Issue Management/Reporting system.*



- a. Secure the buoy to the trailer using ratchet straps. See **Figure 44** for examples of ratchet straps securing the AIS Buoy on the trailer.



Figure 44. Ratchet Straps secure the AIS Buoy to the Trailer

36. Ensure all connections have caps and are secure for storage and double check hardware components for each sensor mount are reinstalled or securely stored with clearly identified instructions to prevent losses or unintentional repurposing of parts for other sites.



Note: *If pulling the buoy from the lake for temporary removal, do not remove the electronics.*

5.3.6.2 Seasonal Storage

Each AIS Buoy requires a seasonal storage unit to protect the infrastructure from winter or temporary seasonal weather (e.g., prevent serious ice accumulation on floating deck for northern sites and destructive tropical depressions/storms and/or Hurricanes at our Florida AIS Buoy sites).

Remove the following instrumentation from the AIS Buoy and store at the Domain Office for temporary storage or send back to CVAL until redeployment in the spring:

1. Multisonde with EXO Link (Send the appropriate probes to CVAL and keep the Body & EXO Link at the Domain Office). Cap the desiccant and cable connection ports on the Multisonde. No matter which sensors are installed in the instrument, it is important to keep them moist without actually immersing them in liquid, which could cause some of them to drift or result in a shorter lifetime. For example, the reference junction of a pH sensor must be kept moist to minimize its response time during usage, but continued immersion in pure water may compromise the function of the glass sensor and/or result in long-term leaching of the reference junction.
 - a. For short-term storage (up to four weeks) of the Multisonde: NEON AIS Science staff recommends placing approximately 0.5 inch (1 cm) of water (tap, DI, of native lake/river water) in the calibration cup that was supplied with the instrument, and by placing the Multisonde with all of the probes in place into the cup. Ensure the calibration cup securely threads onto the Multisonde. The use of a moist sponge instead of a half-inch of water is also acceptable as long as its presence does not compromise the attachment of the calibration cup to the Multisonde.



Ensure the sponge is always moist to prevent sensors from drying out. The calibration cup seals prevent evaporation unless the sponge interferes with the seal.

- b. For interim storage (longer than four weeks): use a minimal amount of water so that the air in the chamber remains at 100% humidity. The water level has to be low enough to prevent immersing the sensors. Use pH 4 buffer or tap water. If the storage water is inadvertently lost during field sampling studies, environmental water is OK to use to provide the humidity. Remove the 4 D-Cell batteries to prevent batteries that were in use for a portion of time from exploding in the instrument battery housing. If Technicians have the original bottle that the pH sensor came with, remove the pH sensor from the Multisonde and cap the port. Place the sensor in the bottle and fill the bottle with 2 molar solution of pH 4 buffer or tap water. Secure the O-ring and cap on the bottle and then tighten.



PRO TIP: *Interim storage of the Multisonde is easy. Simply remember the following key points:*

- *Use enough water to provide humidity for the pH probe, but not enough to cover the probe surfaces.*
 - *Make sure the storage vessel seal is in good condition and secure to minimize evaporation.*
 - *Check the vessel periodically to make certain that water is still present.*
2. PAR Sensors: Upwelling and Downwelling uPAR, PSQ1, and NR01 (Send to CVAL)
 3. HMP-155 sensor (Send to CVAL), HMP-155 Radiation Shield (Store at Domain)
 4. SUNA Sensor (Send to CVAL)
 5. Beacon (Store at Domain)
 - a. Use the IR remote to turn the Beacon OFF to prevent the Beacon from lighting up the LED/using its battery power, while charging. Use the following code via the IR remote:
 - i. Off = "000"
 - ii. Press **Enter**.



Note: *If the Flash Code update was successful, the main LED flashes three times quickly. If the Flash Code update was unsuccessful, the main LED flashes twice slowly. If you were unsuccessful, it means the Flash Code was entered incorrectly. Repeat this process using the Flash Code "000".*

- b. Place the AIS Buoy Beacon in the window of the domain office that receives the most direct sunlight. For sites such as Alaska, place the Beacon in a window likely to receive any sunlight. If the Beacon fails to charge due to lack of sunlight, then replace the Beacon batteries prior to deploying the buoy next year. The Beacon uses lead acid batteries. See **Table 1** for the replacement battery pack part number.
- c. At the bottom of the beacon (post-removal), its software provides a read out for battery state of health. Scroll through the options to see battery state of health.
 - i. Good: A Battery Pack is healthy, and charged (>4.2V).
 - ii. A battery voltage between 3.9V and 4.2V means the battery pack requires charging.
 - iii. A low voltage (<3.9V) means the beacon will not light up at dusk.



Title: NEON Preventive Maintenance Procedure: AIS Buoy		Date: 03/08/2022
NEON Doc. #: NEON.DOC.004613	Author: M. Cavileer, G. Simonds, R. Willingham	Revision: C

6. Garmin GPS (Leave on the Buoy if storage conditions are above -40°C, otherwise store at Domain)
7. Antenna (Leave on the Buoy if storage conditions are above -40°C, otherwise store at Domain)
8. Depth Sounder and pole (Store at Domain)
9. T-Chain (Send to CVAL)
10. Barometric Pressure sensor (Send to CVAL)
11. One or two 100-amp hour batteries sit within the AIS Buoy T-frame battery housing (Store at Domain)
 - a. Place these two batteries in a trickle-charger at the Domain Office to maintain the batteries lifespan when they are not in use.
 - b. If a battery is unable to deliver 11 volts, the system shut downs.
12. Profiler and MET Canisters (Send to CVAL)
13. Store the remaining components, namely the pontoon, profiler hardware and solar panels, outside under a tarp/covered roofing or storage unit (garage). Ensure the tarp/cover affixes to the buoy to prevent unnecessary exposure to the environment and/or mitigate theft/vandalism (e.g., employ some kind of cable/bike lock).
 - a. While in storage, periodically check on the buoy. It is important to prevent freezing and/or thawing of water in the seams and crevices of the buoy and prevent bird/rodent excrement from accumulating on the buoy.

 **Note: If pulling the buoy from the lake for temporary removal, do not remove the electronics.**

5.3.6.3 Redeployment

Redeployment is at the discretion of the Domain Manager; evaluate site characteristics while monitoring for weather events that call for ice, snow or severe wind. Submit a ticket in the NEON Issue Management and Reporting system to coordinate with HQ on unique events/site characteristics.

For re-installation and maintenance, the AIS Buoy must meet NEON.AIS.5.1349 science requirement “The depth of the submerged sensors on buoys shall be measured and recorded with an accuracy of +/- 5 cm during installation and maintenance.” Reference AD [13] and AD [12] for the installation and verification instructions of the AIS Buoy. **Ensure all underwater sensors are out of the water until the buoy connects to the lake/river mooring system.**

A primary concern for instruments during storage are draining the batteries/reducing battery lifespan for specific instruments and the AIS Buoy itself. For redeployment, it may prove beneficial to have smaller battery replacements on hand for the Multisonde (four D-cell internal batteries and O-ring replacement kit with Krytox lubricant) and Beacon (Part # 57383 M650H replacement battery pack). For the two large batteries that power the AIS Buoy system, maintain cognizance on the battery charger to determine when replacements are necessary. Please be aware battery lifespan reduces in cold-water applications.



1. Prior to launch, ensure connectors not in use have caps, the fiberglass T-frame covers are secure and all underwater sensors are above water/secure on the floating platform.
2. See *Section 5.3.6.1* for trailer/towing procedures.
3. For reconnecting the AIS Buoy to its mooring, ensure the following:
 - a. The cotter pins are bent in such a way to allow room for pliers for easy removal (do not bend the cotter pin legs to form around the shackle, just bend them enough to secure the shackle)
 - b. The mooring rope allows for at least one meter of vertical travel to account for water level changes.
 - c. See *Section 5.3.4* to adjust the mooring system.
4. See *Section 6.2.6* to reconnect the Profiler and the MET canister, and conduct the necessary offsets for the data collection. ***This action requires a compass and level and must occur whenever the MET canister incurs a placement adjustment or undergoes Sensor Refresh for your site.***
 - a. See *Section 5.3.2* to reference the port connections on each canister.
5. Per NEON AIS Science Requirements, maintain all submerged sensors at 0.5 meter to prevent wear and tear on the cables, unless otherwise directed per AIS science requirements.
 - a. See *Section 6.2.1* to reinstall the Multisonde.

 **PRO TIP:** *The Multisonde comes with a custom YSI tool to remove the sensor probes. This tool is in a hidden compartment inside the Multisonde manufacturer's box. Technicians may have to conduct a minor scavenger hunt to find the tool within the Multisonde original packaging, if one was not originally provided with the Multisonde integration/verification or if a replacement Multisonde is sent to a Domain.*

- b. See *Section 6.2.2* to reconnect the PAR and SUNA sensors on the dual PAR SUNA mount and Retractable PAR mounting system for the D03 FLNT AIS Buoy.
6. See *Section 5.3.6.1* to use the reverse order mount the Met Mast Instruments, Beacon, auxiliary Solar Panels, reconnect Batteries, and other remaining components.
 - a. For the RM Young Wind Vane: Install the propeller on the shaft with the serial number on the propeller facing forward (into the wind).
 - b. For the Beacon, check Battery state of health on the AIS Buoy post-installation using the IR Remote.
 - i. Press and hold any button for approximately three seconds.
 - ii. Press the **Start** button on the IR Remote. The On-Board User Interface (OBUI) displays "I r Pr" briefly to indicate that it has received the IR signal.
 - iii. Enter the User Passcode **750**. Each time a user enters one of the digits for the Passcode, the OBUI flashes "I r X" (where X indicates the button a user presses on the IR Remote. For example, if a user presses the up button on the IR Remote, the display reads "I r U P" or "I r O 9" displays when a user presses the 9 button, etc.).
 - iv. Press the **Enter** button on the IR Remote. If the main LED was on, it extinguishes and then flashes three times quickly to indicate that the Passcode entry was successful.



- v. Point the IR Remote at the side of the M650H lens and then press the **Start** button on the IR Remote (**Figure 45**). The main LED flashes once.

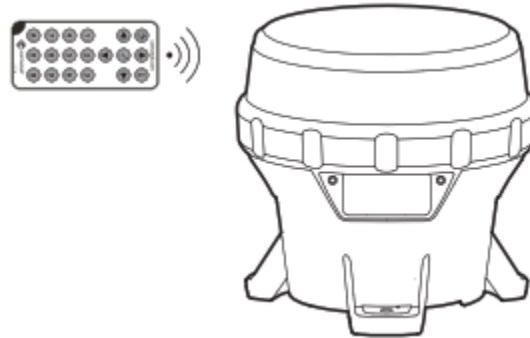



Figure 45. Carmanah M650H Beacon with IR Remote (Source ER [02])

- vi. Enter **810** using the IR Remote. The main LED flashes once each time the M650H receives a signal.
- vii. Press Start on the IR Remote. The main LED flashes once, and if the command entry was successful, the main LED will flash three times quickly, and then display the Battery Pack's state of health using a series of flashes from the main LED. The M650H will report its battery status twice to ensure users are able to count all the flashes. Use the following information to determine the Battery Pack's state of health.
 - 1. 4 Flashes = Bad Battery Pack
 - 2. 5 Flashes = Low Voltage
 - 3. 7 Flashes = Requires Charging
 - 4. 10 Flashes = Good Battery Pack (fully charged)
- c. **Good:** A Battery Pack is healthy, and charged (>4.2V).
- d. A battery voltage between 3.9V and 4.2V means the battery pack requires charging.
- e. A low voltage (<3.9V) means the beacon will not light up at dusk.

 **PRO TIP:** The beacon flashes are difficult to see during daylight. Conduct this procedure on a cloudy day during daylight/dusk or bring material to cover/shade the beacon to see the light patterns.

 **Note:** TOMB and BLWA AIS Buoys are recognized as private navigation aids by the United States Coast Guard (USCG) river navigation charts. These two AIS Buoys are classified as a "NEON Special Lighted Scientific Monitoring Buoy", which requires a specific beacon lighting pattern (i.e., flash period of 2.2 and flash length of 0.3 for both TOMB and BLWA river locations). The manufacturer (Carmanah) provided the NEON project with the ability to program the special light pattern into our current beacons for these locations. **See AD [21] for additional information on the Beacon (AIS Buoy Beacon Verification Procedures).**

- 7. For the T-Chain, sensor length varies per site. Some AIS site T-chains were modified to fit site length requirements by removing the temperature probe from the chain (**Figure 46**). If this modification is



present on your T-Chain, ensure the temperature probe holes are plugged to prevent water intrusion into the internal sensor mechanism before reinstallation.

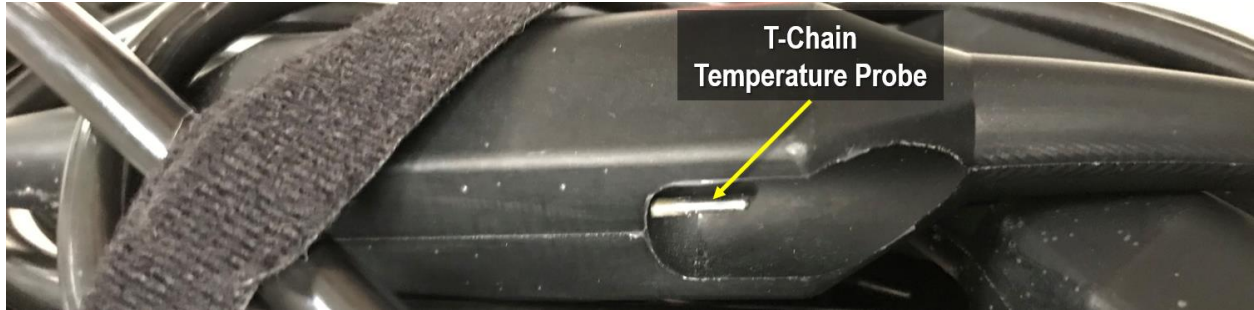

Figure 46. T-Chain Sensor – Temperature Probe





Title: NEON Preventive Maintenance Procedure: AIS Buoy		Date: 03/08/2022
NEON Doc. #: NEON.DOC.004613	Author: M. Cavileer, G. Simonds, R. Willingham	Revision: C

6 REMOVAL AND REPLACEMENT (SUBSYSTEM ONLY)

6.1 Equipment

Reference Table 1 for the equipment and materials to conduct the procedures in this section.

 *Note: Maintain original product packaging, if possible, for use in future sensor swaps (calibration and validation), temporary storage, or to return faulty equipment.*

 *Note: Save the any connection port caps for later use. Reinstall the caps to connections for storage, moving and/or shipping.*

6.2 Removal and Replacement Procedure

The Field Operations Domain Manager is responsible for managing the removal and replacement of the sensors onsite for preventive maintenance and/or sensor swaps and manages field calibration and validation of sensors, as appropriate. The NEON project Calibration, Validation and Audit Laboratory (CVAL) is responsible for the calibration and validation of select sensors and manages Domain sensor refresh (swap) schedules.

To minimize data downtime and optimize the availability of sound data, coordinate instrumentation and subsystem **annual** calibration, validation and preventive maintenance requirements to occur within the same timeframe. See **Table 5** for Sensor Refresh requirements applicable to the AIS Buoy sensor sets. Asset tags must accompany each sensor returning to CVAL and reflect CFGLOC changes in NEON's project Asset Management and Logistic Tracking System. **Table 9** in *Section 6.3 Cleaning & Packaging of Returned Sensor* compliments the information in this table with graphical examples.

Table 5. AIS Buoy Instrumentation Calibration and Validation Requirements Summary

INSTRUMENT	LOCATION		TIMEFRAME			COMMENTS
	CVAL	FIELD	BIWEEKLY	ANNUAL	NA	
<i>Multisonde with EXO Link (Suspends under T-Frame or is fixed from grated deck and within T-Frame for D03 FLNT)</i>		X	See Comment			Reference AD[04]. Field Validation (Second Reference CVAL Sensor) occurs quarterly. Send the five probe sensors to CVAL and keep Multisonde body, central wiper & EXO link at the Domain. The pH probe sensor must be kept moist. No EXO Link on D03 FLINT AIS Buoy.
<i>SUNA (In Cage on Dual PAR SUNA Mount or is fixed from grated deck for D03 FLNT)</i>	X			See Comment		Reference AD[06]. Only send the SUNA to CVAL when the lamp requires replacement. This may occur annually or over a longer duration depending on how long the buoy is operational at your



INSTRUMENT	LOCATION		TIMEFRAME			COMMENTS
	CVAL	FIELD	BIWEEKLY	ANNUAL	NA	
						site. Immediately cease updating the reference spectrum in the SUNA software wizard per NEON-12977. Continue biweekly cleaning, and the recording of pre- and post- cleaning blank values with fresh deionized water. Package SUNA in a pelican case for Sensor Refresh.
<i>Upwelling & Downwelling uPAR sensors (On each end of Dual PAR SUNA Mount Cage or Retractable PAR Mounting System for D03 FLNT)</i>	X			X		Return to CVAL per Domain/Site Sensor Refresh Schedule. Place black plastic caps at the optical end of the sensor. Employ ESD protocols for shipping/ handling. Reference AD[16].
<i>Barometric Pressure Sensor (Under Canisters within T-Frame)</i>	X			X		Return to CVAL per Domain/Site Sensor Refresh Schedule. Employ ESD protocols for shipping/ handling. Reference AD[19].
<i>T-Chain (Off Bow of Buoy or under T-Frame for D03 FLNT)</i>	X			X		Return to CVAL per Domain/Site Sensor Refresh Schedule. Requires plug in connector to prevent water intrusion. See Figure X.
<i>Depth Sounder</i>					X	The depth sounder may reach or misread a depth that is thick with lakebed/river muck. This instrument is power hungry when in use. D03 FLNT AIS Buoy does not have a depth sounder. Remove the Depth Sounder for winterization and store at the Domain/Storage Facility.
<i>PSQ1 (On Radiation Boom, MET Mast)</i>	X			X		Return to CVAL per Domain/Site Sensor Refresh Schedule.
<i>NR01 (On Radiation Boom, MET Mast)</i>	X			X		Return to CVAL per Domain/Site Sensor Refresh Schedule.
<i>RM Young Wind (On Met Mast)</i>	X			X		Return to CVAL per Domain/Site Sensor Refresh Schedule. Remove propeller for shipping/handling.
<i>HMP-155 (on MET Mast)</i>	X			X		Return to CVAL per Domain/Site Sensor Refresh Schedule. The Radiation Shield and mounting infrastructure remains at Domain/Storage Facility. Ship sensor with yellow protective cap over the filter. Employ ESD



Title: NEON Preventive Maintenance Procedure: AIS Buoy		Date: 03/08/2022
NEON Doc. #: NEON.DOC.004613	Author: M. Cavileer, G. Simonds, R. Willingham	Revision: C

INSTRUMENT	LOCATION		TIMEFRAME			COMMENTS
	CVAL	FIELD	BIWEEKLY	ANNUAL	NA	
						Protocols for shipping/handling. Reference AD [18].
CR1000 Data Logger (In Profile Canister)	X			X		Return to CVAL per Domain/Site Sensor Refresh Schedule. This canister also contains desiccant. Keep the green ground wire at the Domain!
CR1000 Data Logger (In MET Canister)	X			X		Return to CVAL per Domain/Site Sensor Refresh Schedule. This canister also contains the Compass and desiccant.
Aquatic Portal Precipitation (Precip) DIN Rail: AIS Buoy Subsystem Components					X	Reference AD [17].

Note: Maintain the AIS Buoy sensor sets asset tags in the AIS Buoy battery box or closest onshore device post (e.g., the Aquatics Portal). Use option one or option two, do not split of up tags between the two options. **Do not send a sensor to CVAL without its asset tag.**

After installation of the sensors, verify sensor data state of health (Data Product) in the [SAS report](#) the next day (this report updates every 24 hours). Validate sensor data stream(s) and LO data is good (in green).

PRO TIP: Reference [AD \[12\]](#) for Test Case: NEON Data Streams for a list of operational data streams to expect post-Sensor Refresh.

6.2.1 Profiler Multisonde Removal and Replacement

This procedure provides guidance on removing and replacing the Multisonde for field calibrations/validations. Conduct the following procedures to remove and replace the Multisonde from the AIS Buoy profiling winch assembly.

1. Unlatch and slide off the T-Frame cover where the Profiler Canister resides. **The handles for the fiberglass T-Frame cover are not for lifting purposes; they guide the housing on and off the track.**
 - a. Note: If the system is currently using the Multisonde to conduct profile measurements, wait for it to complete the sequence and place the system in PARK.
2. Connect a laptop to the Controller Assembly using the diagnostic cable. Attach the buoy serial cable to the RS-232 diagnostic port on the profiler (lower) canister to a laptop using a USB to serial adapter. **Figure 47** displays the RS-232 diagnostic port in green.

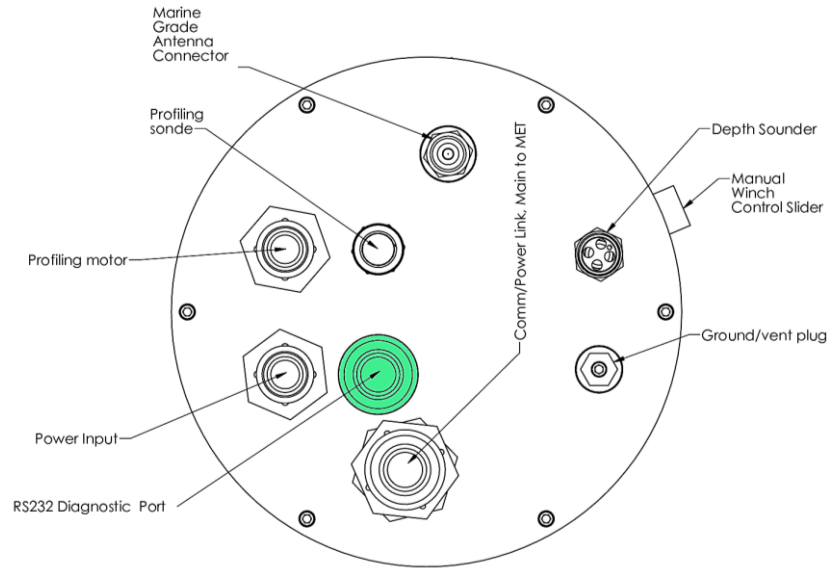

Figure 47. RS-232 Diagnostic Port on Profile Canister (Lower Canister) in Green

3. Start LoggerNet™ and connect to the canister.
4. From the **Connect Screen**, use the “**Ports and Flags**” function to track activity. Note: At this point, Flag 2 should be OFF (low).
5. Turn **Flag [1]** on (high) then **Flag [2]** on (high) by clicking on the green dot/light icon. This stops the AIS Buoy from profiling and places the Profiler system into Setup Mode, keeping it in idle (PARK) mode for the duration of the procedure. **Figure 48** is an example of when **Flag [2]** is on (high) (this may take a minute to display).
 - a. If the AIS Buoy is not profiling, skip **Flag [1]** and click **Flag [2]** on (high) directly; however, there is no harm in clicking **Flag [1]**, then **Flag [2]** every time. (If it is not profiling, clicking Flag [1] will not result in anything.)

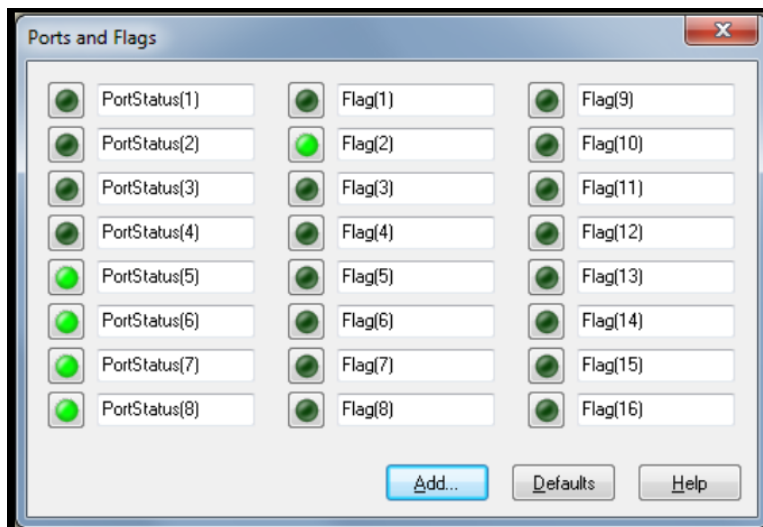

Figure 48. Flag 2 (High)



6. Use the magnetic switch to initiate manual function of the winch in PARK mode to add two feet of slack on the winch cable to enable lifting the Multisonde onto the AIS Buoy floating deck. This prevents dropping the Multisonde and EXO Link into the lake.
 - a. A magnetic wand attaches to a string inside the T-Frame next to the battery enclosures, hanging off the profiler canister (lower canister). On the left side of the profiler is a small oblong slot. Waving the magnetic wand across the window activates the winch (see **Figure 49**).
 - i. To lower the winch, slide the magnetic wand to the left along the slot.
 - ii. To raise the winch, slide the magnetic wand along the window to the right.



Figure 49. Magnetic Switch to Activate the Winch

 **Note:** The magnet automatically puts the profiler into setup mode. Do not use it after setting up a profiling sequence.

- b. If the magnetic switch fails, manually adjust the winch – grab the winch spool and turn it.
7. Disconnect the Multisonde with EXO Link from the winch by disconnecting the carabineer connecting to the winch and EXO link (see **Figure 50**).

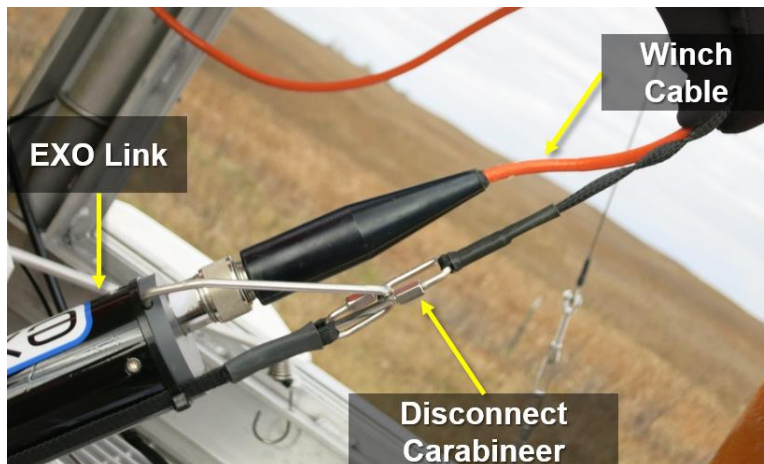

Figure 50. Disconnect Multisonde from the Lake Buoy Winch



i Note: In the event the Multisonde with EXO Link requires manual retrieval using the AIS Buoy winch system, avoid pulling the EXO-Link too far into the winch. The winch controller includes a current limiter, which should shut it off in the case of binding. The coupler between the motor and the transmission is also a weak link in the system and will break first to prevent damage to the winch system.

8. Replace/Reinstall D-Cell batteries. Inspect Multisonde battery compartment and condition of O-rings while conducting this task. Grease O-rings post-winterization/Sensor Refresh. Use **Figure 51** and the instruction below to complete this step. Reference *Table 1* for battery replacement recommendations, O-ring replacement kit and Krytox GPL 205 grease part numbers.



Figure 51. How to Replace Multisonde Internal D-Cell Batteries and Grease O-Rings (Source: [ER \[16\]](#))

9. Clean sensor ports and reinstall sensor probes using the YSI probe reinstallation tool (**Figure 52**).

a. If the port is dirty or wet, clean it with a clean, lint-free cloth or compressed air.



Figure 52. Multisonde Probe Tool and Krytox GPL 205 Lubricant Use (Source: [ER \[16\]](#))



- b. Apply a light coat of Krytox grease to the rubber mating surfaces of the connector (not the O-ring) and a small dab of Krytox grease on the threads of the locking nut post-winterization/Sensor Refresh (**Figure 52**).
- c. Taking care not to cross-thread the grooves, finger-tighten the locking nut clockwise. **Do not to twist the probe body when tightening and loosening the locking nut.** Excessive twisting of the probe can damage the connector. When the nut and O-ring are seated against the bulkhead, tighten the nut with probe tool 1/4 turn until snug. Once sensors or plugs are installed, reinstall the sensor guard to protect sensors from impact damage.
- d. *Reference AD [04] to conduct the appropriate field calibration and validation procedures.*

 **PRO TIP:** YSI recommends using two guards: one for field deployments and a second used exclusively for calibrations. Using a second guard will minimize calibration solution contamination (especially for turbidity). EXO calibration cups install over an installed sensor guard. This configuration reduces the amount of standards required for calibration and protects the sensors during calibration. ⁱⁱⁱ

10. After servicing the Multisonde, reconnect the Multisonde with the EXO Link to the winch via the same carabineer that was disconnected in Step 7.
11. Lower the instrument into the water connected to the winch cable. No need to make any manual adjustments to the winch.

 **Note:** The cable connection must thread through the steel bar and red (or orange) spool (see **Figure 53**, called a V-roller suspension assembly to protect the cable from snagging while profiling). Never return the Multisonde into the water under the Winch Assembly without ensuring the winch cable threads properly.

12. Exit set up mode by setting **Flag [2]** off (low). Click on the bright green dot to turn it dark green (off).
13. To start profiling immediately, set **Flag [5]** on (high).
14. Click “Disconnect” and disconnect the cable from the RS-232 diagnostic port.
15. Cap the diagnostic port.
16. Guide the T-frame cover over the tracks to close it and secure it via its latches.

IMPORTANT: A note on set up, the Multisonde requires its fourth parameter set to **Vertical Position** (meters) instead of Depth (meters) for Stream 4. This is only a requirement for Multisonde measuring the vertical profile of a fresh water lake from an AIS Buoy.



Figure 53. Thread the Winch Cable Properly to Return Multisonde to Water



6.2.2 D03 FLNT ONLY: Pump Profiler Multisonde Removal and Replacement

This procedure provides guidance on removing and replacing the Multisonde for field calibrations/validations. Conduct the following procedures to remove and replace the Multisonde from the AIS Buoy profiling pump assembly.

1. Unlatch and slide off the T-Frame cover where the Profiler Canister resides. **The handles for the fiberglass T-Frame cover are not for lifting purposes; they guide the housing on and off the track.**
2. For sensor refresh, power down the Multisonde sensor and pump subsystem by removing the power input cable from the canister (**Figure 54**).

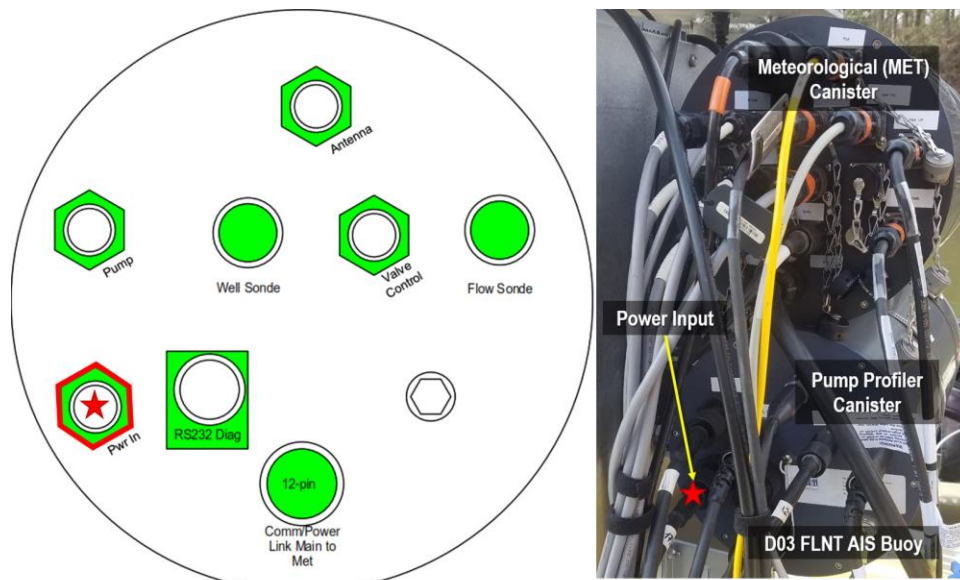

Figure 54. Pump Profiler Canister | Power Input Cable Location in Red with Star Symbol

3. Remove the **Flow Sonde** cable from the profiler canister and the sensor (since the canister and the sensor require annual calibration at HQ). The Multisonde is on the opposite side of the T-Frame.
4. Use a wrench to remove the Multisonde from the two clamps (**Figure 55**).



Figure 55. Use Wrench to Remove the Multisonde from the Two Clamps

5. Disconnect the two hoses connected to the flow cell (Figure 56). Push down on the silver area and it releases the hose.

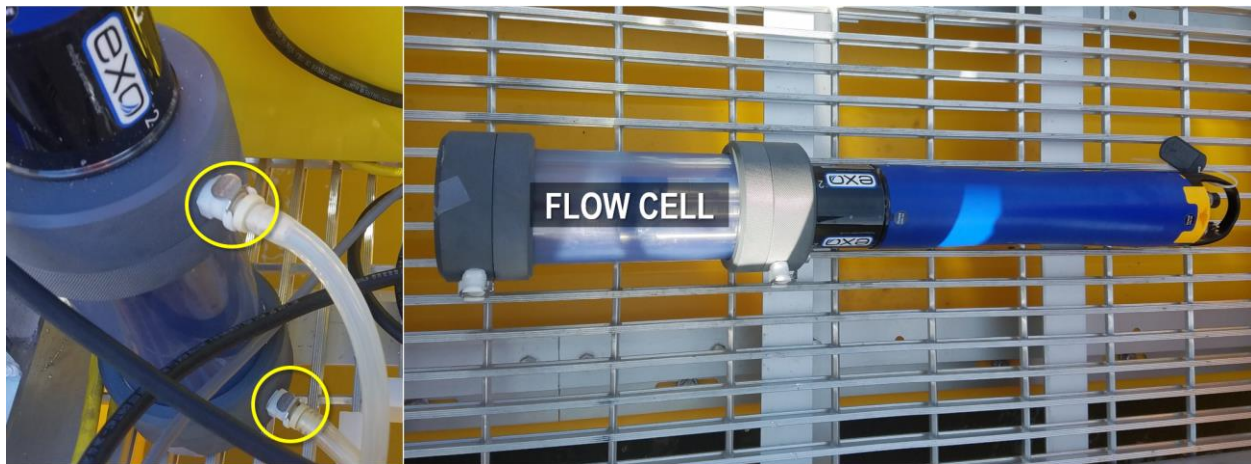

Figure 56. Remove Multisonde from Flow Cell

6. Unscrew the flow cell from the Multisonde (as you would with the protective brass guard).
7. Use the reverse order of these instructions to reconnect and reinstall the Multisonde.
 - a. Conduct Steps 8-9 in Section 6.2.1 Profiler Multisonde Removal and Replacement.

6.2.3 SUNA and uPAR Removal and Replacement for Dual PAR SUNA Mount

This procedure provides guidance on removing and replacing the SUNA and uPAR sensors for field calibrations/validations and/or general maintenance. Conduct the following procedures to remove and replace the SUNA and uPAR sensors from the AIS Buoy dual PAR SUNA Mount.

1. Wear a life vest and gloves, and have a second Technician with you to act as a spotter.



2. Disconnect the two guy-wires from the eyebolts. These guy-wires stabilize the mount to the AIS Buoy when submerged (see **Figure 21** in *Section 5.3.2*) locking carabineers.
3. The SUNA and uPAR sensors mount to a bracket that must manually lift from the water. This bracket requires a lifting technique to lift out of the water.

Dual PAR SUNA Mount Lifting Techniques:

Technique #1: Squat down and grasp the metal part of the arm right where it joins to the composite arm that sticks into the water. See **Figure 58** for start point reference. Apply a pulling force parallel to the composite arm –at first, pull straight up, but as the mount rises out of the water, pull more horizontal. Once the SUNA clears the water surface, have a spotter stand to the side to lend a hand when the mount becomes its heaviest. ***It is important, especially once the sensors are out of the water, to sink down and use your legs; making sure you engage core/leg muscles, instead of your back/arm muscles is key.*** (Source: Torey Ploeger)

Technique #2: Straddle the metal arm (feet close to the edge of the buoy) and grab the bracket with both hands to lift the mount up. See **Figure 58** for start point reference. Lean back using your weight to lift the mount above water. As the SUNA breaches the water, the mount reaches its heaviest weight. It gradually becomes lighter the higher the mount lifts. (Source: Geoff Simonds)

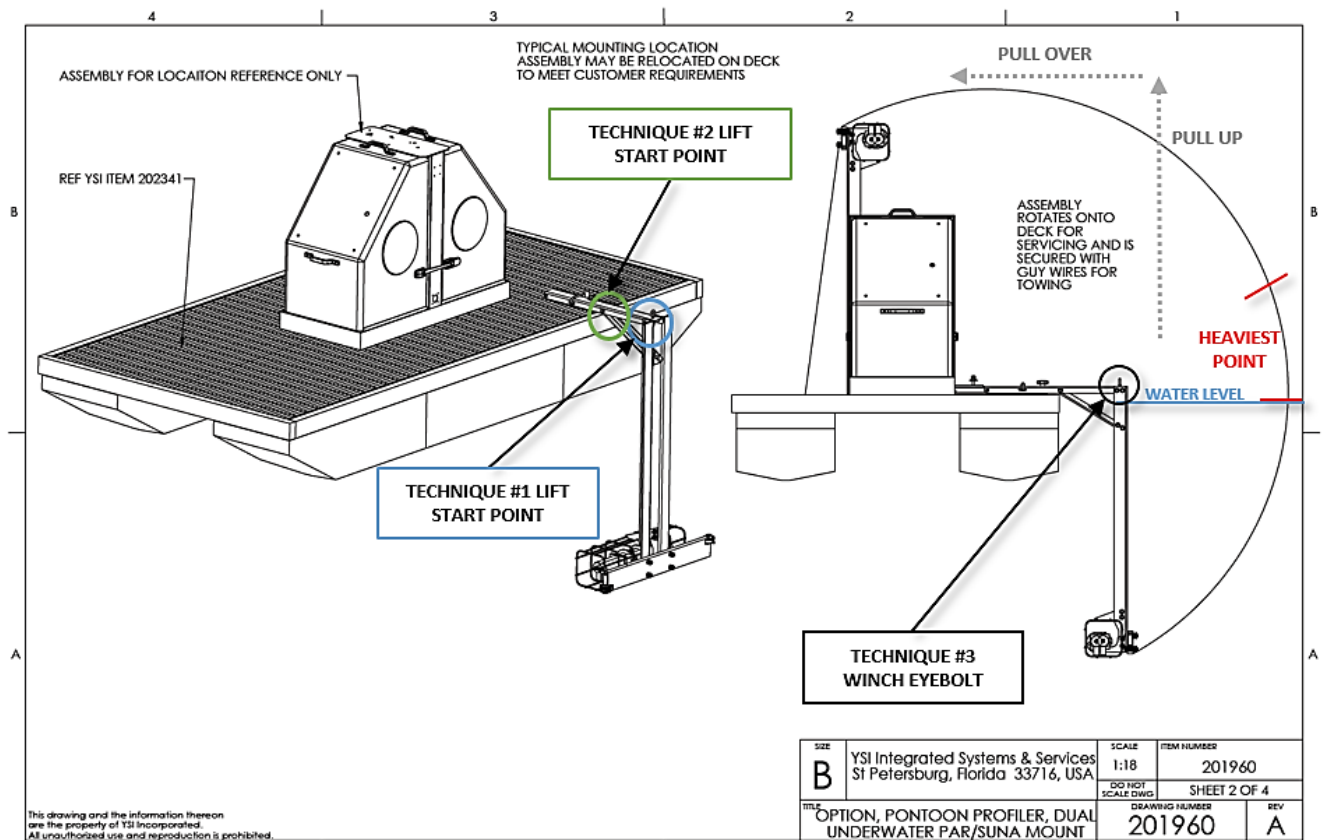

Figure 58. Dual PAR SUNA Mount Lifting Guidance

Technique #3: This technique employs a NEON custom component to assist in raising the mount over the heaviest point. This technique employs a portable winch, which connects to the winch bracket between the winch bracket and the eyebolt near the 90-degree joint of the arm (Figure 57). The winch pulls the mount out of the water to over the center of the buoy where a Technician must guide it down to the bracket in the floating deck.

Table 6 provides the procedure to remove/reinstall the SUNA and uPAR sensors.

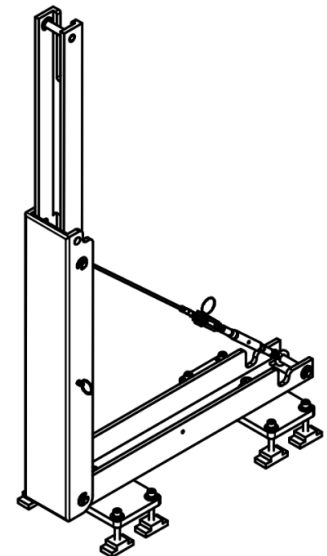

Figure 57. Buoy Dual PAR/SUNA Winch



Table 6. AIS Buoy SUNA & uPAR Removal/Reinstallation Procedure for Dual PAR/SUNA Mount

STEP 1 | The power may remain ON to clean the uPAR sensors, as long as an **AIS Data Quality** ticket is submitted with the timeframe and a brief description of the maintenance scope work. Otherwise, power down the AIS Buoy in accordance with AD [07] to act as a “flag” for data quality.

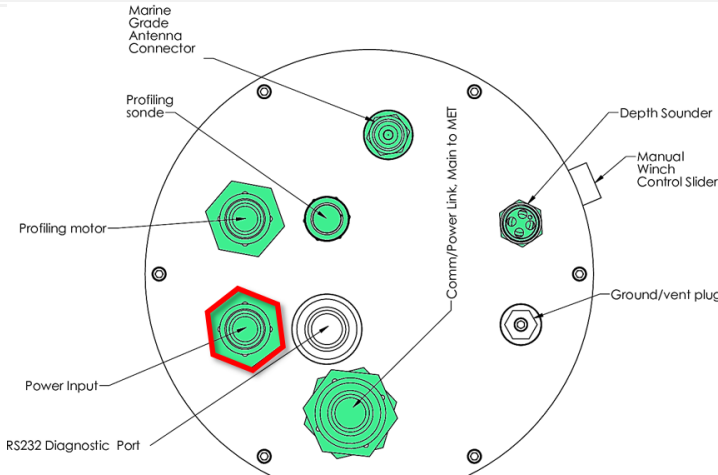

Figure 59. Profile Canister Port Mapping (Source: [AD \[13\]](#))

For annual Sensor Refresh, power down the buoy by disconnecting the bolts from the battery or unplug the Power Input cord from the profiler canister. (Power Input port is in red in Figure 59.)

Disconnect the sensors power cord from the MET Canister in accordance with Figure 16. MET Canister Port Mapping on page 22 or AD [13].

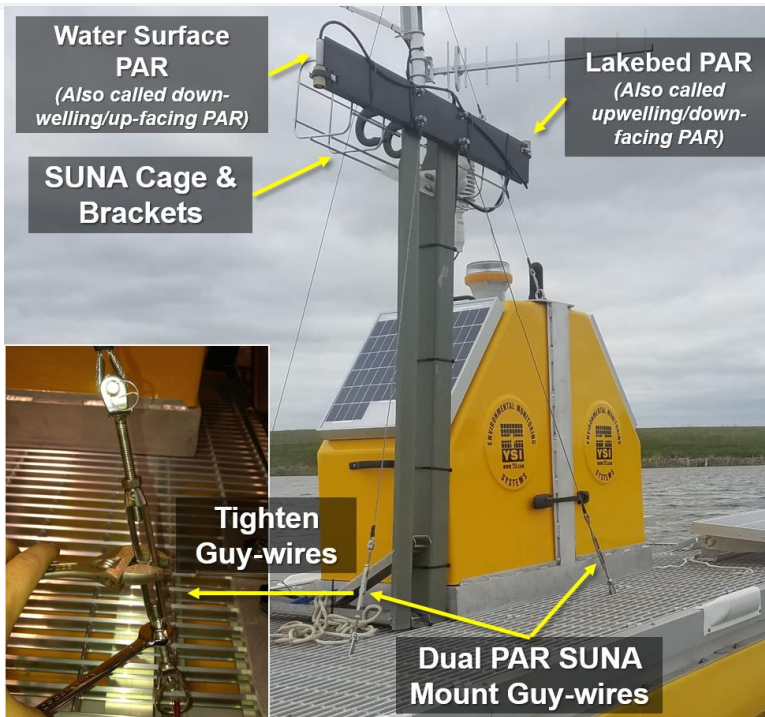

Figure 60. Raise the Dual PAR/SUNA Mount on the AIS Buoy

STEP 2 | Disconnect the two locking carabineers from the eyebolts on the side of the buoy stabilizing the mount underwater. Lift the mount to seat on the deck per Figure 60. Secure the mount to the deck using the guy-wire turnbuckles.

PRO TIP: Figure 60 is also an example of how the AIS Buoy should look when towing it on/offshore.

For D03 FLNT AIS Buoy, please reference the next section for additional instructions to address the variations in the AIS Buoy model.

STEP 3 | Pop the SUNA out of the cage from the three clamps using a small amount of force (Figure 61). Use a firm grip, hold onto the cage with one hand and push on the SUNA with the other hand (Picture 1 and 2 in Figure 61). This frees it from the two black clamps in the cage. Slide the SUNA out either from



below or above the two clamps (Picture 3-7 in Figure 61). Reach in a pull the SUNA out while supporting it with your hands (Picture 8 in Figure 61).

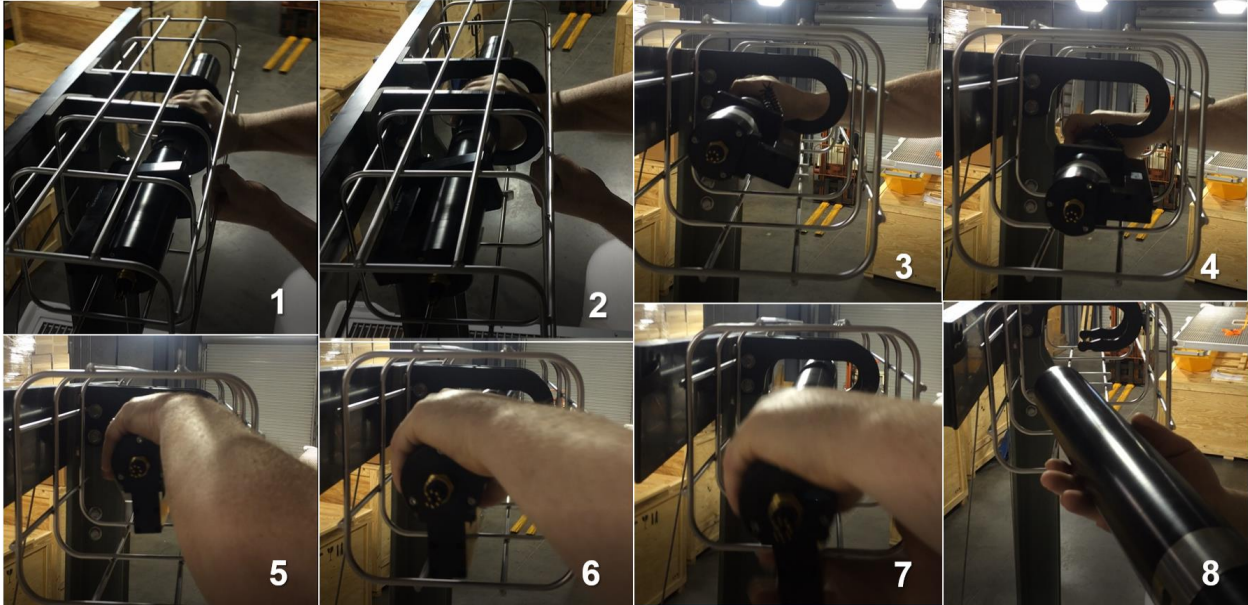

Figure 61. Remove SUNA from Dual PAR SUNA Mount Cage Clamps (Source: YSI Mechanical Engineer, Allen Hunter)

STEP 4 | To reinstall, slide the SUNA into the cage until the wiper is almost flush with the first black clamp (Picture 1-4 in Figure 62). Reach in-between the cage and pull and the SUNA toward you until it locks into place (Picture 5 in Figure 62). Reference AD [06] to conduct field calibrations and validations for the SUNA.

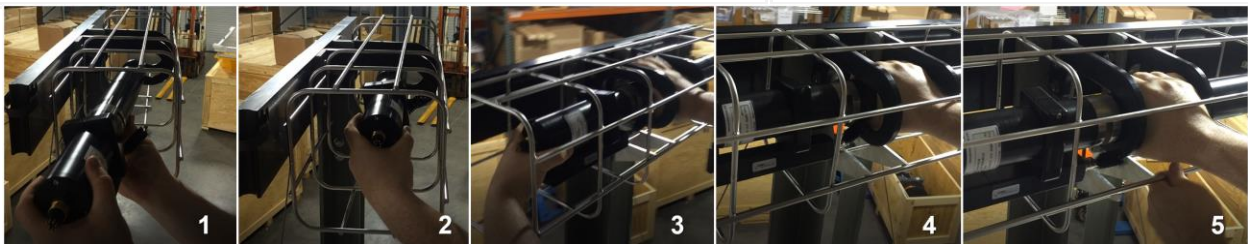



Figure 62. Reinstall SUNA from Dual PAR SUNA Mount Cage Clamps (Source: YSI Mechanical Engineer, Allen Hunter)

PRO TIP: See Section 10 APPENDIX C: Connecting to the SUNA on the Buoy on page 85 to connect to the SUNA on the AIS Buoy to check configuration and reset the SUNA clock. This process is a more effective and easier means of connecting to the SUNA than through the Grape, and recommended for use at both SUNA In-Stream (S-2) and AIS Buoy locations. However, in the event it is not safe to connect to the SUNA on the buoy, connect to the SUNA via the Merlot Grape at the MET Station onshore.



Figure 63. Use Screwdriver or Nut Driver to Remove uPAR Sensor from Mount

STEP 5 | Use a flathead screwdriver to remove the uPAR sensor from the Dual PAR/SUNA Mount hose clamp (Figure 63). Place black plastic caps at the optical end of the sensor.

 **PRO TIP:** For sites removing the uPAR sensors for winterization of the AIS Buoy, use electrical tape to differentiate between the two to aid reinstallation.

 **Note:** Handle the AIS Buoy PAR sensors with care; as a rule, do not use a dry brush on any of the optical sensors on the buoy (two uPAR sensors, PSQ1 and NR01).



Figure 64. Replace with "New" Sensor

STEP 6 | Place a new "refreshed" sensor in the Dual PAR/SUNA mount hose clamp (Figure 64).

For winterization, reinstall the uPAR bracket hardware (i.e., thread screw back in pipe clamp) without the sensor.



Figure 65. Secure Sensor in Mount

STEP 7 | Use a screwdriver or Nut Driver to secure the “refreshed” uPAR sensor on the Dual PAR/SUNA Mount (Figure 65).

Note: Maintain the AIS Buoy sensor sets asset tags in the AIS Buoy battery box or closest onshore device post (e.g., the Aquatics Portal). Use option one or option two, do not split up tags between the two options. Do not send a sensor to CVAL without its asset tag.

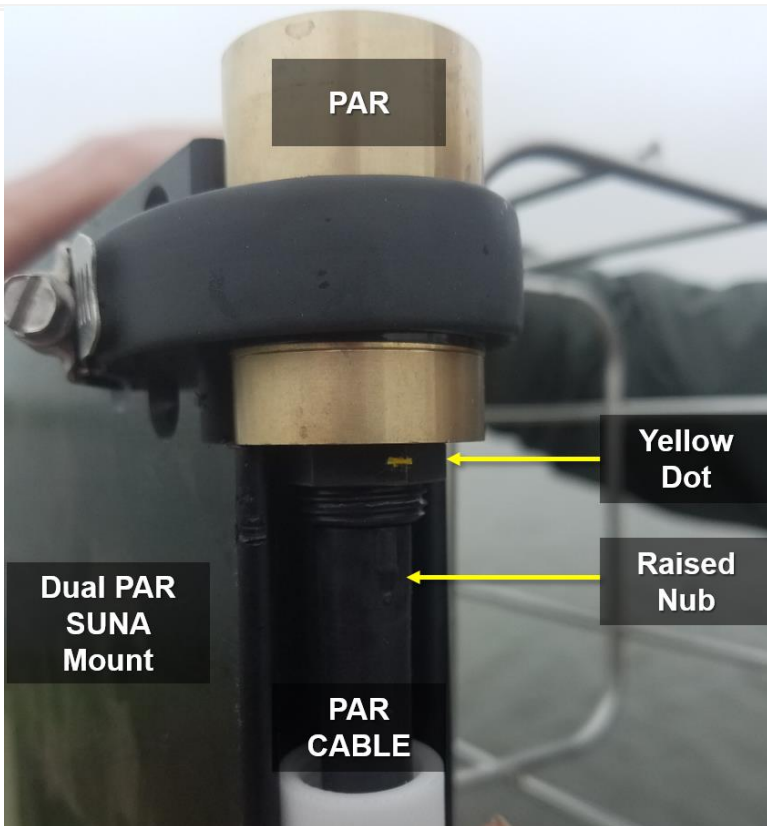

Figure 66. Align uPAR Sensor and Cable

STEP 8 | In the event the uPAR is not connected to its cable, use Figure 66 as a guide.

The yellow dot and raised nub must align to connect the cable to the sensor. If the dots do not align, this may result in a negative reading on the readout device due to the change in polarity of the conductors.

Note: The sensor connector may need periodic lubrication with a silicone grease (e.g. Dow Corning 111, available from LICOR under product number 210-01958-1) before installing it in the mating connector of the underwater cable.

STEP 6 | Reconnect sensor power cables to the MET Canister in accordance with Figure 16. MET Canister Port Mapping on page 22 or AD [13].



STEP 9 | Disconnect the guy-wires from the floating deck via their locking carabineers. Slowly lower the mount towards the water with the help of a spotter. ***As soon as the mount hits the water, it significantly reduces in weight and requires a lot less effort to lower.*** However, before reaching that point, the mount reaches its heaviest point, which may feel like it is going to pull you into the water. The mount, at its heaviest, is not far from the water (it should not be too far above the water, see Figure 58 above), so it is OK to let go of the mount if you feel you are losing control or if it is actually pulling you overboard.

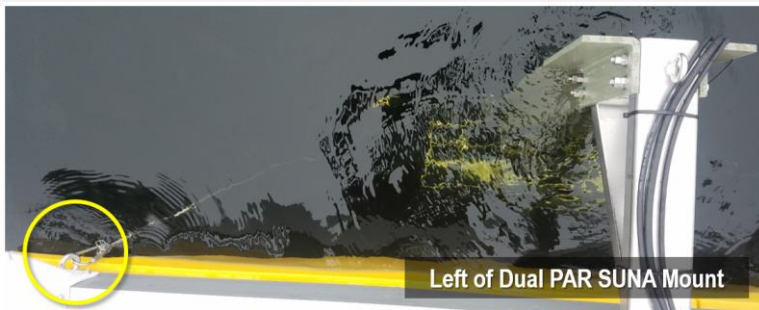

Figure 67. Underwater Eyebolts for Dual PAR SUNA Mount

STEP 10 | Re-attach the guy-wires via the locking carabineers to each eyebolt underwater (Figure 67).

STEP 11 | Verify sensor function on post reinstallation.

6.2.4 uPAR Removal and Replacement for Retractable uPAR Mounting System

This procedure provides guidance on removing and replacing the two uPAR sensors from a retractable PAR mounting system (Figure 68) for general maintenance or Sensor Refresh. This mounting system design only exists for D03 FLNT AIS Buoy at the time of publishing Version B of this document.

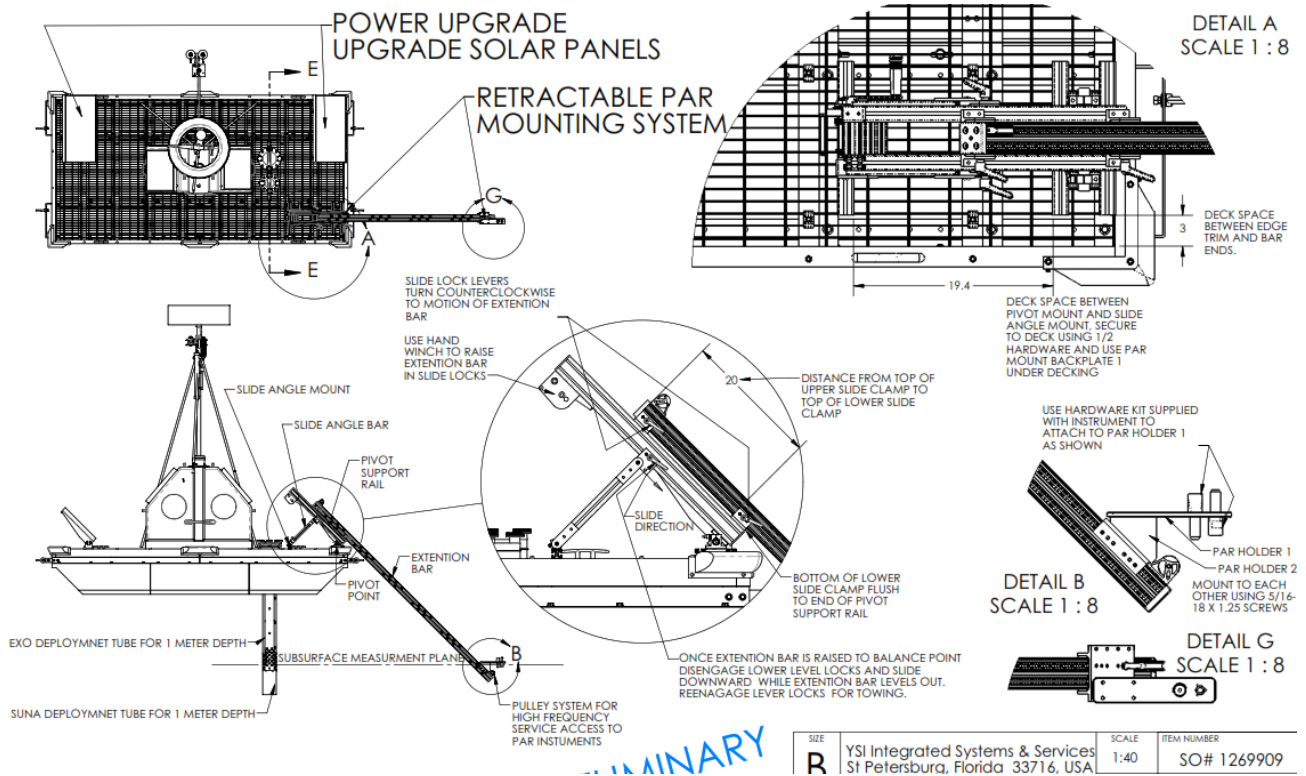

Figure 68. Retractable PAR Mounting System | FLNT River Buoy (Source: YSI Integrated Systems & Services)^{iv}

Use Table 7 for guidance on removing/replacing the uPAR sensors for this mounting system.

Table 7. AIS Buoy uPAR Removal/Reinstallation Procedure for Retractable PAR Mounting System

STEP 1 | The power may remain ON to clean the uPAR sensors, as long as an **AIS Data Quality** ticket is submitted with the timeframe and a brief description of the maintenance scope work. Otherwise, power down the AIS Buoy in accordance with AD [07] to act as a “flag” for data quality.

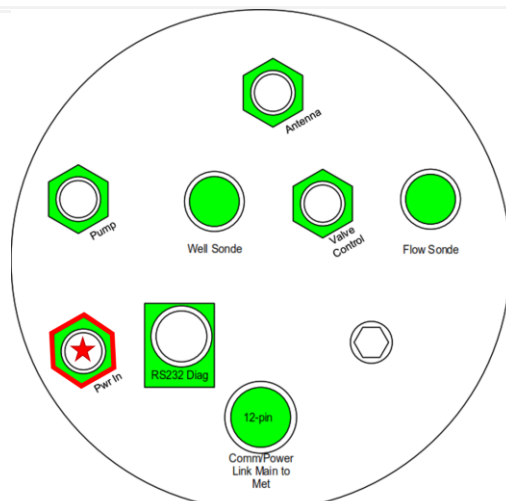

Figure 69. Pump Profiler Canister Port Mapping (Source: AD [13])

For annual Sensor Refresh, Power down the buoy by disconnecting the bolts from the battery or unplug the Power Input cord from the profiler canister. (Power Input port is in red with a red star in Figure 69.)

Disconnect the sensors power cord from the MET Canister in accordance with Figure 16. MET Canister Port Mapping in AD [13].



Figure 70. Release Two Slide Locks to Bring Extension Bar uPAR Mount Above Water

STEP 2 | Release the two slide locks securing the extension bar with PAR mount underwater (in yellow in Figure 70).

 **PRO TIP:** For just cleaning the PAR sensors, pull on the cable to bring the PAR mount above or below water.



Figure 71. uPAR Mount Winch

STEP 3 | Crank the winch (Figure 71) to lower and raise the extension bar with uPAR mount above or below water.

Use a dry brush and river water to scrub off debris/bio-fouling/animal excrement in the mount tracks, etc.



Figure 72. Lock Slide Locks to Secure Sensors Above Water

STEP 4 | Lock the same slide locks to secure the sensors above water (Figure 72).

Remove each uPAR from the mount by removing three #6-32 screws. (LICOR provides the hardware for the uPAR. 9901-220 Underwater Parts Kit, QTY 2 – 1 for each uPAR.)

STEP 5 | Conduct this process in reverse to reinstall new uPAR sensors onto the AIS Buoy for D03 FLNT.



6.2.5 D03 FLINT ONLY: Multisonde and SUNA Sensor Removal and Replacement for Fixed Underwater Tube Mounts

This section specifically applies to D03 FLNT AIS Buoy removal and replacement of the fixed underwater tube mounts for the SUNA and Multisonde (**Figure 73**) in **Table 8**.

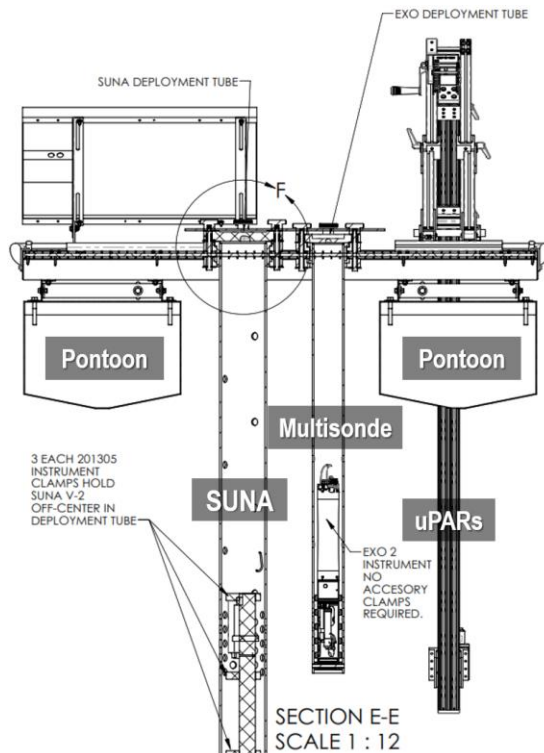

Figure 73. Fixed Submerged Sensors on D03 FLNT AIS Buoy: Multisonde & SUNA Tube Mounts

Table 8. AIS Buoy Multisonde & SUNA Removal/Reinstallation Procedure for D03 FLNT Fixed Tube Mounts

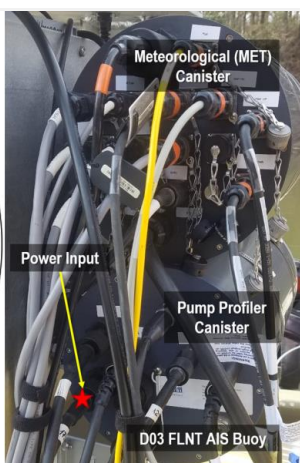
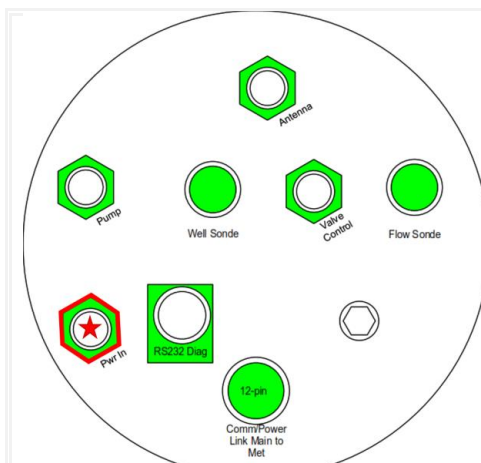

Figure 74. Pump Profiler Canister Port Mapping (Source: [AD \[13\]](#))

STEP 1 | For annual Sensor Refresh, Power down the buoy by disconnecting the bolts from the battery or unplug the Power Input cord from the pump profiler canister (Figure 74).

Disconnect the sensors power cord from the MET Canister in accordance with [AD \[13\]](#).

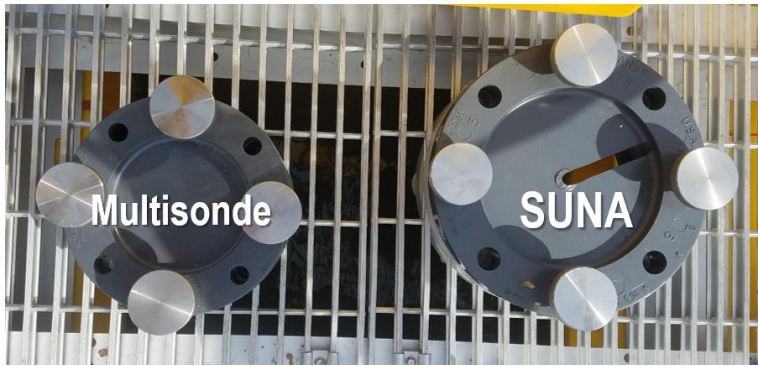

Figure 75. Multisonde & SUNA Tube Mount Caps with Stainless Steel Knobs

STEP 2 | Location of the **Well Sonde** Multisonde and SUNA sensors (Figure 75). 1/2-13 X 5.5 inch bolts secure flange rings to the deck and fender washers cover the oversized bolt holes.



Figure 76. Remove Four Stainless Steel Knobs to Remove Tube

STEP 3 | Remove the four stainless steel knobs on the cap to access (Figure 76).



Figure 77. Lift Cap to Access Sensor in Tube

STEP 4 | Lift cap to access the sensor (Figure 77). Remove the Multisonde.

Pull the Multisonde up from the cable with locking carbiner.



Figure 78. Remove Fixed Sensor Tube from Water

STEP 5 | Lift the tube up by gripping the flange (Figure 78).

PRO TIP: if it gets stuck from being pushed downstream while pulling it up use a boat hook/paddle to torque it back upstream.

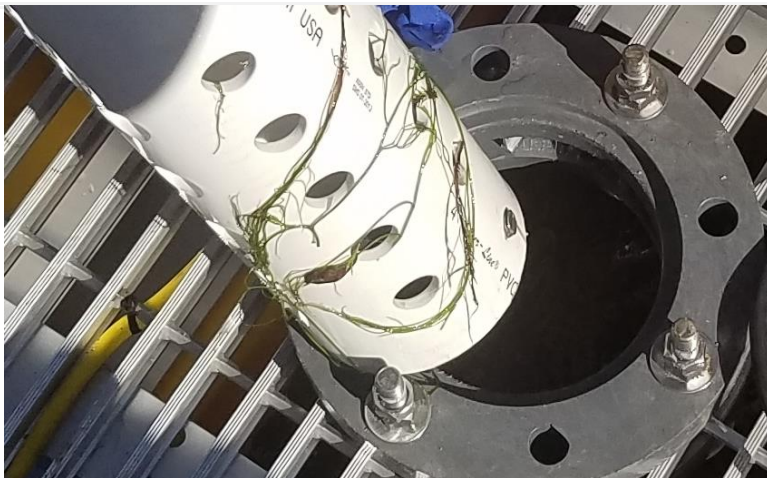

Figure 79. Fixed Sensor Tube Collecting Debris from River

STEP 6 | Clean biofouling/debris from the PVC tube with a drybrush and river water. Remove large pieces of river debris and place them back into the water.

Figure 79 is an example of river debris accumulating on the fixed sensor tubes in D03 FLNT.



Figure 80. Align Cable with Notch where Cap/Lid mates with bottom Flange

STEP 7 | When reinstalling the cap, ensure the cable aligns with the slit/slot for it to travel to the canister (Figure 80).

A notch exists where the lid mates to the bottom flange. Ensure the cable goes into the chase.



Figure 81. SUNA Fixed Tube

STEP 8 | Removing the SUNA is the same process as the Multisonde, but pull up the fixed PVC tube for the SUNA slowly so it drains water for easier lifting/removal (Figure 81).

PRO TIP: Clean the bio-fouling from the sensor biweekly or at least once a month to ensure the build it does not become very difficult or impossible when the SUNA requires decontamination (Source: [NEON-12946](#)).

Note: FOPS must cease field calibrations for the SUNA. Continue performing biweekly cleanings. See [NEON-12977](#) for more information.



Figure 82. SUNA Wiper Placement

STEP 9 | Ensure the wiper motor aligns within the area identified in yellow in Figure 82.



6.2.6 Profiler and MET Canister Removal and Replacement

The CR1000 data loggers in the Profiler and MET PVC canister enclosures require annual calibration via CVAL. Employ ESD protocols as a precaution. To Remove/replace the Met and Profiler Canisters, conduct the following procedure.

1. Unlatch and slide off the fiberglass T-Frame cover where the PVC canisters reside (the canisters face the stern of the AIS Buoy). Reference **Figure 83**.

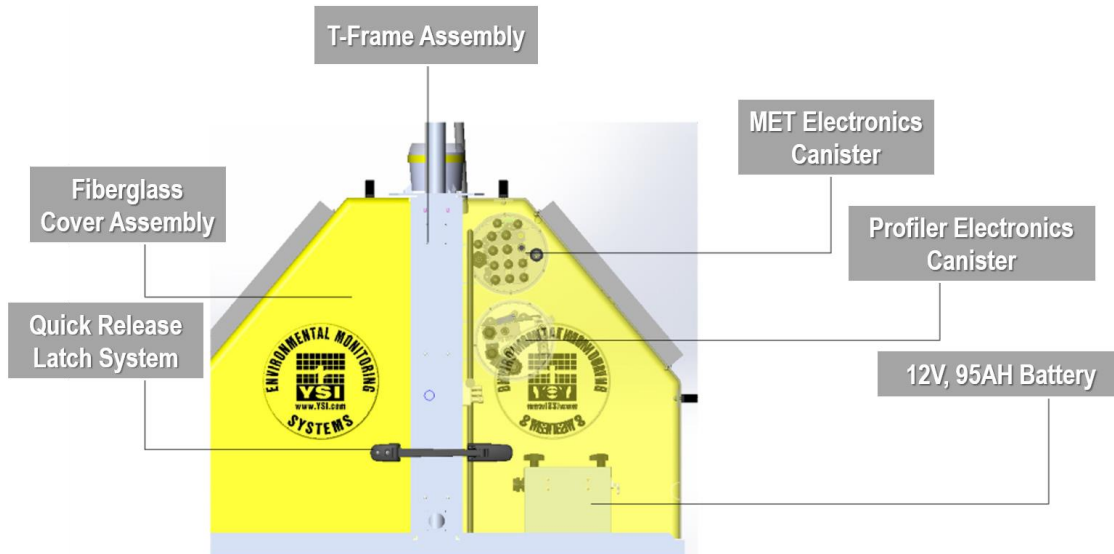

Figure 83. T-Frame/Cover Exterior and Interior Components

2. Power down the AIS Buoy by disconnecting the Power Input cable from the battery box.
3. Disconnect all the connections on the canisters. Do not disconnect the **“Comm Power Link Main to Met”** connector on the Met Canister. This cable is hardwired to the Met canister and does not disconnect. Technicians disconnect this connector from the Profile (Winch or Pump) canister ONLY.

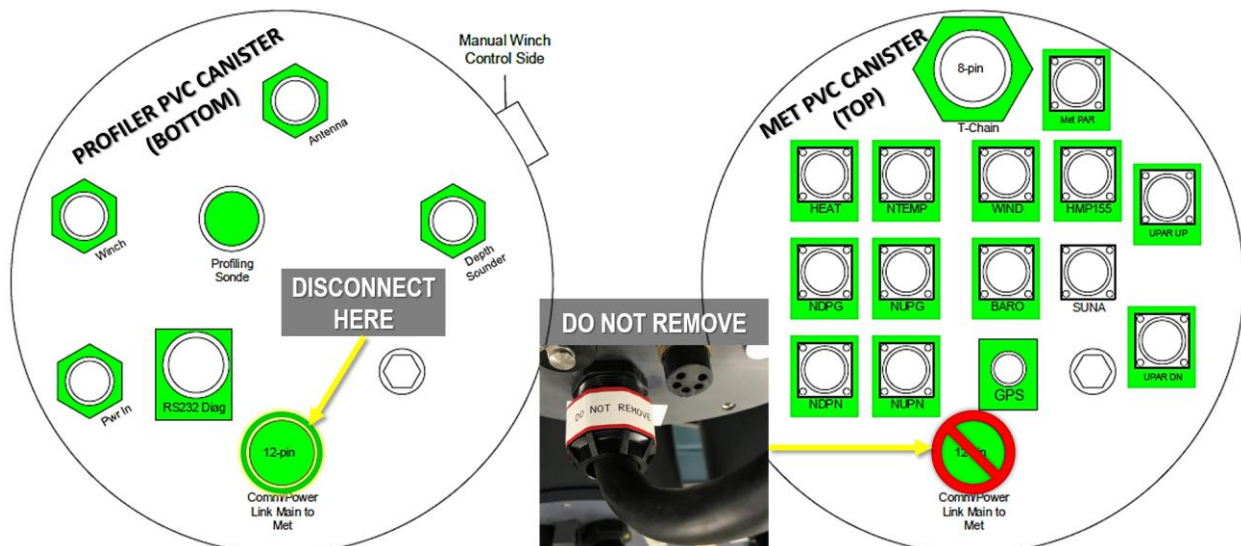



Figure 84. Do not disconnect the “Comm Power Link Main to Met” Connector on the Met Canister

4. Each canister secures to the T-Frame via two large clamps. **Figure 85** displays the location of each canister and their hose clamps.
5. Use a flathead screwdriver to disconnect the four hose clamps and maneuver the canisters free from their grip.
6. Cap each connector. Do not pack the green ground wire. Keep that at the Domain.

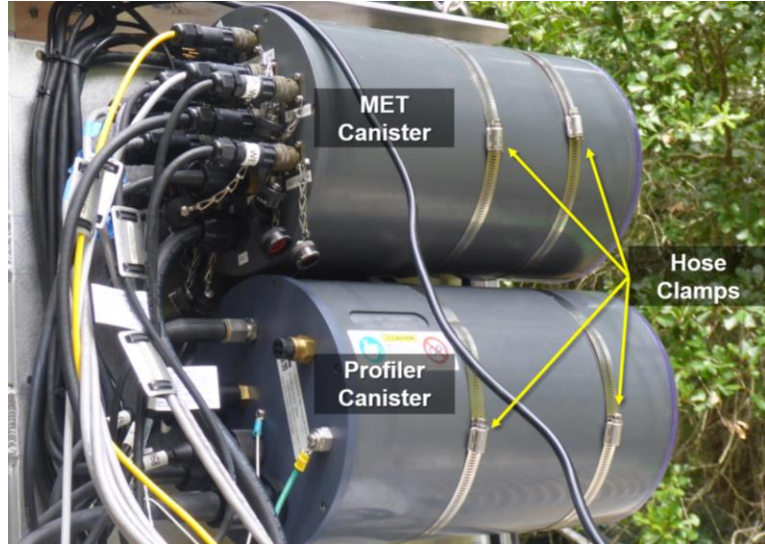

Figure 85. PVC Canister Enclosures for MET and Winch or Pump Profiler

7. Package the canisters in a pelican case(s) provided by CVAL as part of your Domain/Sites annual sensor refresh. If you do not have a pelican case(s), please contact CVAL two weeks prior to removing the AIS Buoy for seasonal storage or canisters sensor refresh to request shipping materials.
8. Use bubble wrap to fill the gaps/pack the canisters into the container tight.
9. Use the reverse order of the removal instructions for replacement procedures with exception of the next step. Complete this next step every time the canisters undergo adjustments in their placement, Sensor Refresh, or replacement/installation after corrective action or winter storage.
10. When replacing/moving the canisters when the AIS Buoy is operational, always capture the physical and logical (LoggerNet) offset³ for the digital compass in the MET canister. The offset corrects the RM Young Wind (2D Wind) data. Collect the following measurements and use the equations in the text box to record the offsets to provide AIS Science for data quality.

$$\textit{Heading Offset} = \textit{Heading}_{\textit{LoggerNet}} - \textit{Heading}_{\textit{physical}}$$

$$\textit{Roll Offset} = \textit{Roll}_{\textit{LoggerNet}} - \textit{Roll}_{\textit{physical}}$$

- a. Use a digital compass to measure the **Heading**. Use the MET software to logically capture this value (instructions below).

³ NEON.AIS.4.1742 The buoy shall include a digital compass for horizontal wind direction data correction relative to true north.
NEON.AIS.4.1745 The buoy shall include an accelerometer to flag radiation data when the buoy is off-level.



- i. Take the compass and set it on the edge of the starboard side of the floating deck centerline. Capture this measurement in the boat next to the AIS Buoy. (Note: The side with the winch may throw off the compass measurements.)

- b. Use a digital level and digital compass to physically capture the **Pitch** and **Roll**. Use the MET software to logically capture these values (instructions below).

- i. Take a digital level and measure the PITCH by placing it on the top of the floating deck along the centerline (at the bow, to measure from bow to stern). Positive PITCH is bow above stern. Capture this measurement in the boat next to the AIS Buoy (your movement can influence the measurement). See **Figure 86** for reference.

- ii. Take a digital compass and measure the ROLL from port to starboard. Positive ROLL is port above starboard. See **Figure 86** for reference.

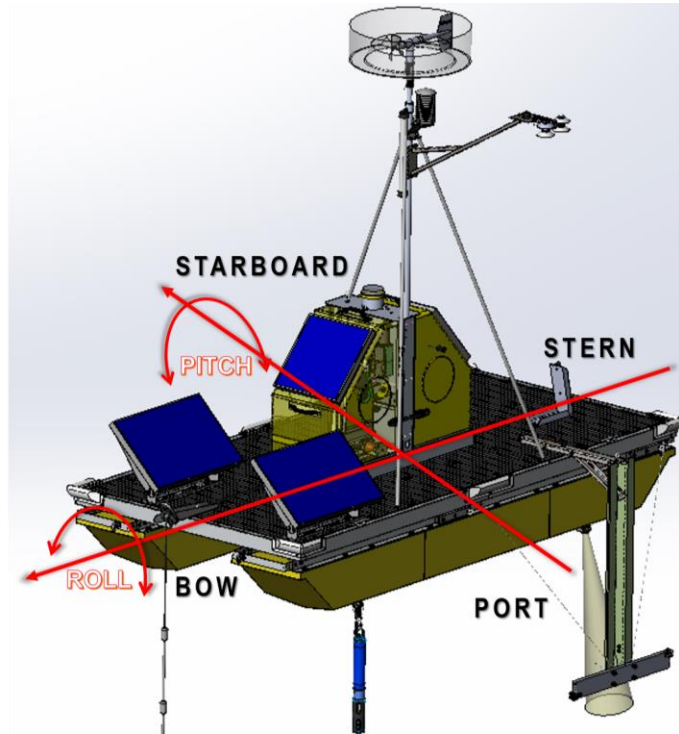

Figure 86. AIS Buoy Pitch and Roll Diagram

- c. To capture these measurements logically, connect a laptop to the Controller Assembly using the diagnostic cable. Attach the buoy serial cable to the RS-232 diagnostic port on the profiler (lower) canister to a laptop using a USB to serial adapter.
- d. Start LoggerNet™ and connect to the canister.
- e. Click **“Connect”**.
- f. Click **“Num Display”** (see **Figure 87**) to open the Data View.

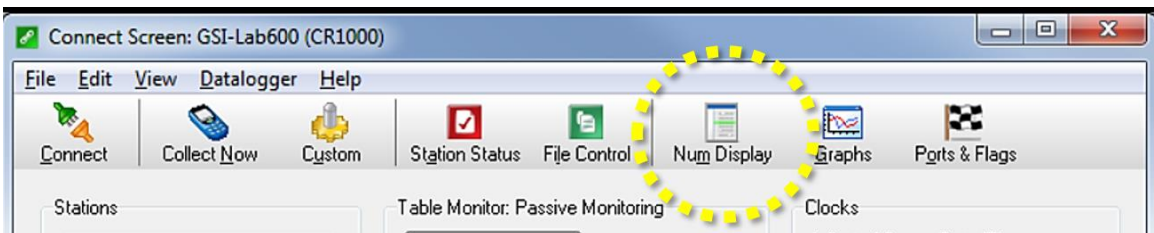

Figure 87. Click "Num Display" Icon



Title: NEON Preventive Maintenance Procedure: AIS Buoy		Date: 03/08/2022
NEON Doc. #: NEON.DOC.004613	Author: M. Cavileer, G. Simonds, R. Willingham	Revision: C

- g. If Data View does not display any parameters, see *Section 8 APPENDIX A: Checking for Humidity in the Profile/MET Canisters, Step 5* to load in a pre-existing configuration to view MET data (text files).
 - i. To add your own parameter, select a box and click “Add”.
 - ii. Select a parameter from one of the many available Tables; the **Public Table** holds current data.
- h. Record the values for **HEADING**, **PITCH** and **ROLL** to go along with the physical measurements made with the compass and level. See **Figure 88** below.

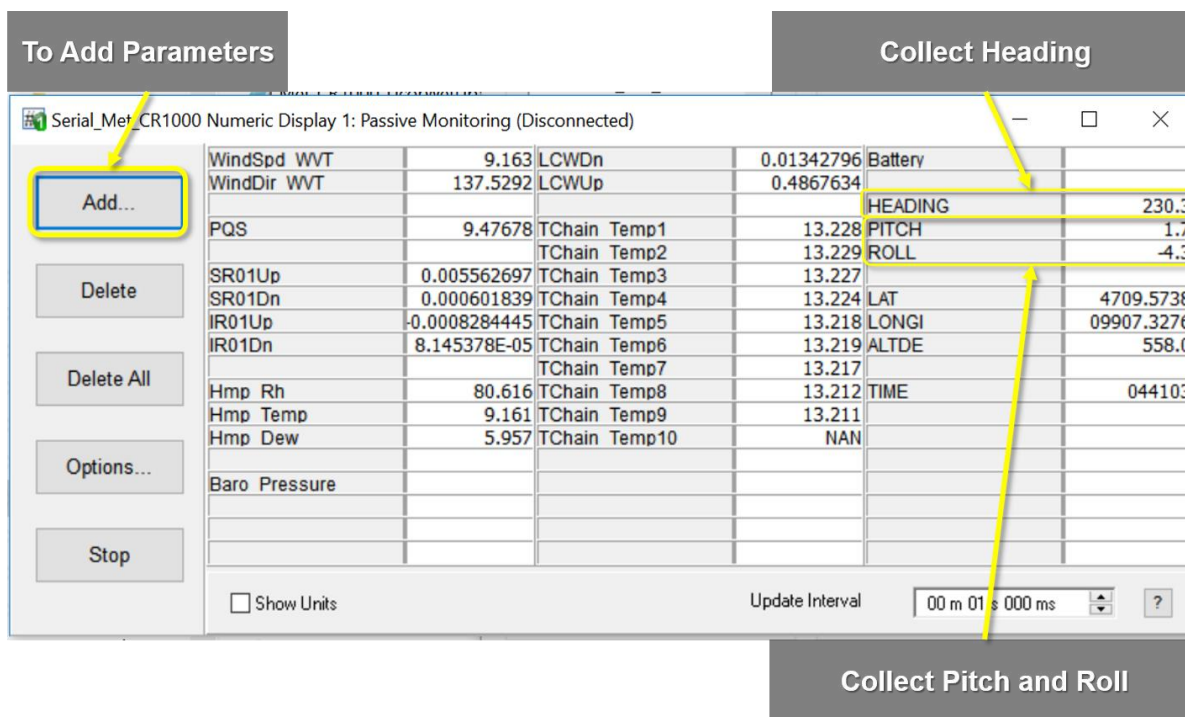

Figure 88. Collect Heading, Pitch and Roll for Offsets

11. After collecting the values, click “X” to exit the Numeric Display window.
12. Click “Disconnect” and disconnect the cable from the RS-232 diagnostic port.
13. Cap the diagnostic port.
14. Guide the T-frame cover over the tracks to close it and secure it via its latches.
15. Submit/save/send the offset information to an AIS Science approved location or POC.

6.3 Cleaning & Packaging of Returned Sensor

Field Operations staff decontaminate, package, and ship sensors back to the CVAL at the NEON project HQ (Battelle Ecology) for annual Sensor Refresh (swap)/calibration requirements. (Please note: if a sensor is defective, submit a trouble ticket and affix a red tag with the trouble ticket number on it. See *Section 7* for additional instruction). Asset tags must accompany each sensor returning to CVAL and reflect CFGLOC changes in NEON’s project Asset Management and Logistic Tracking System. Use **Table 9**



Title: NEON Preventive Maintenance Procedure: AIS Buoy		Date: 03/08/2022
NEON Doc. #: NEON.DOC.004613	Author: M. Cavileer, G. Simonds, R. Willingham	Revision: C

to reference packaging requirements for most of the AIS Buoy sensor and subsystems requiring annual calibration and validation at HQ.

Table 9. AIS Buoy Sensor Packaging Requirements

STEP 1 | Conduct decontamination on each sensor in accordance with [AD \[08\]](#).

STEP 2 | Package dry sensors according to the specific guidelines Section 6 of each sensor and/or subsystem in the preventive maintenance document. Ship sensors in containers (e.g., pelican cases or similar) with pertinent protective hardware (e.g., caps/ESD bags/bubble wrap). Secure any moving parts and loose cables that may incur damage or damage contents. If Domains are missing shipping containers or protective hardware, submit an issue ticket to request additional supplies from CVAL. Below is a visual summary of the AIS Buoy sensors that have additional packing requirements per Chapter 6 of their preventive maintenance document.

 *Note: For sites conducting Sensor Refresh during the winterization of the AIS Buoy: When CVAL returns the AIS Buoy sensors “refreshed”, FOPS must store and maintain the packing/shipping containers for the next Sensor Refresh and winterization timeframe.*



Figure 89. SUNA in a Pelican Case

Submersible Ultraviolet Nitrate Analyzer (SUNA) | **0329950100** Sensor, Buoy, SUNA Nitrate with Integrated Wiper, Titanium Housing

Post-decontamination, pack the sensor dry with its asset tag in a pelican case (Figure 89) provided by CVAL.



Figure 90. Multisonde Probes/Sensors

Multisonde | **HB07530100** Assembly, Kit, Multisonde with Sensors, FDOM
0320170001 Sensor, Conductivity/Temp
0320170004 Sensor, DO (Optical)
0320170004 Sensor, Turbidity, 0320170005 Sensor, Total Algae 0320170006 Sensor, fDOM, 0320170015 Sensor, pH/ORP

Post-decontamination, pack each probe individually dry with exception of the pH probe (Figure 90). For the pH probe, use a container provided by the manufacturer with pH 4 or 7 or return it to CVAL in a plastic bag with a wet towel and some water if you do not



have this container for it (no spare containers are available).

PRO TIP: [YSI Solution Expiration Dates.](#)

Note: [SDS pH 4](#), [SDS pH 7](#), [SDS pH 10](#).

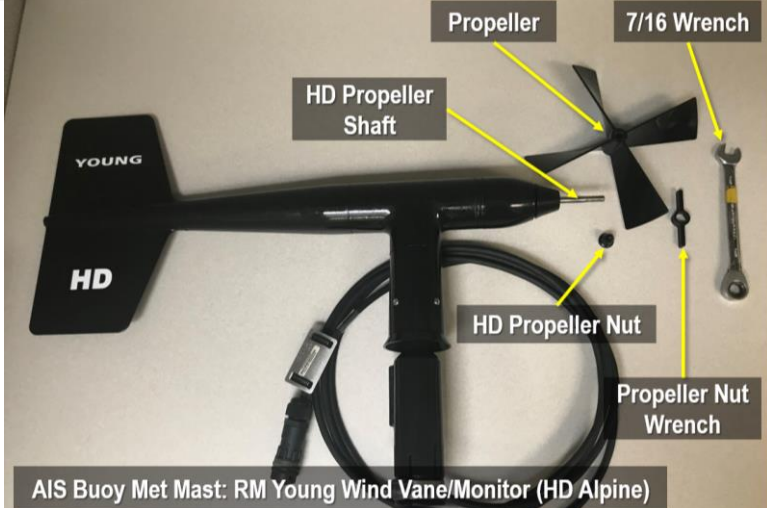

AIS Buoy Met Mast: RM Young Wind Vane/Monitor (HD Alpine)

Figure 91. RM Young Wind Vane Propeller Parts/Equipment for Removal

RM Young Wind Vane | **0348380000**
Sensor, Buoy, 2D Wind, RM Young 05108

The RM Young Wind Vane has an oversized HD propeller shaft, high pitch propeller and locking HD propeller nut (Figure 91).

Use a propeller nut wrench or 7/16 wrench to remove the propeller from the wind vane (Figure 91 and Figure 92). Place the propeller nut back onto the propeller shaft after removing the propeller. This ensures the nut is not lost in packing materials.

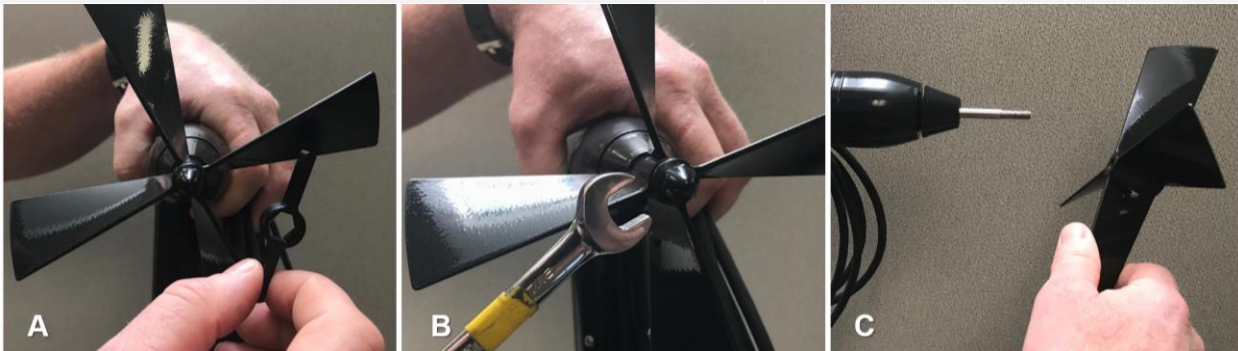

Figure 92. How to Remove the Propeller from the RM Young Wind Vane



Figure 93. Vaisala HMP-155 Sensor with Yellow Protective Cap

HMP-155 | **0348410000** Sensor, Buoy, Humidity, HMP155

Cap the HMP-155 filter with a yellow protective cap (Figure 93). Cap and coil the sensor cable in ESD packaging. Leave mounting components at the Domain (Figure 93).

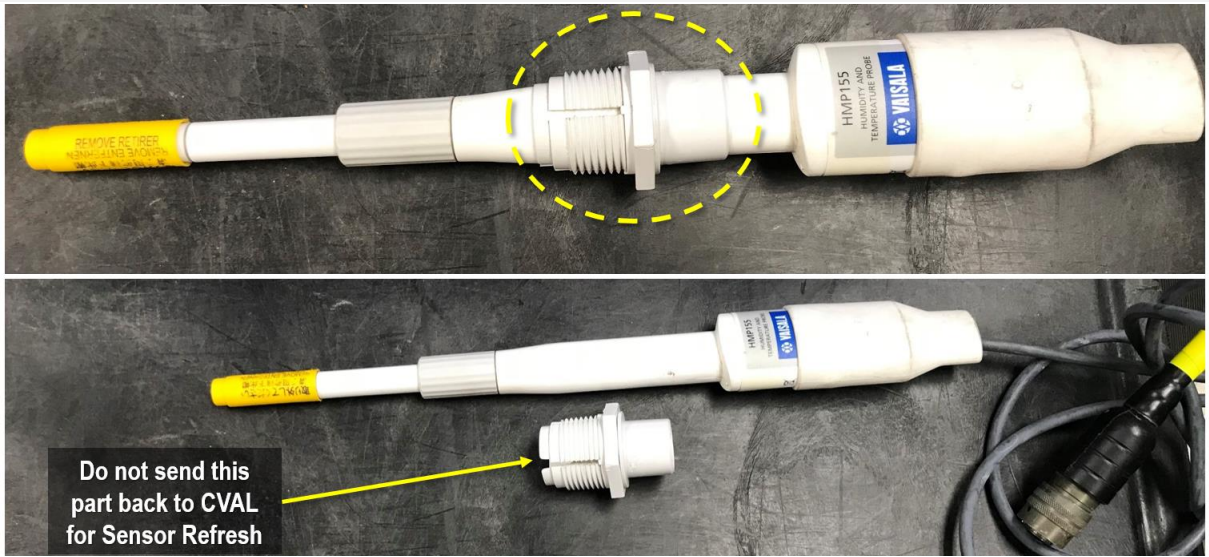

Figure 94. Vaisala HMP-155 Sensor with Yellow Protective Cap & Radiation Shield Mounting Component – Do Not Send to CVAL



Figure 95. Vaisala Barometric Pressure Sensor - Requires ESD Packaging

Barometric Pressure sensor | **0348400000** Sensor, Buoy, Barometric Pressure (Figure 95)



Figure 96. PQS1/PAR Sensor with Black Cap over Diffuser – Req. ESD

PAR Sensor | **0348420000** Sensor, Buoy, PAR, PQS-1 (Figure 96)



Figure 97. uPAR Sensor with Black Cap over Diffuser – Req. ESD

uPAR | **0348390000** Sensor, Buoy, Underwater PAR (Figure 97)

Figure 97 is applicable for both Upwelling and Downwelling uPAR sensors.



Figure 98. NR01 with Black Caps over Diffuser – Req. ESD

NR01 | **0349250000** Sensor, Buoy, Net Radiation, NR01 (Figure 98 and Figure 99)



Figure 99. Cap Cables



Figure 100. T-Chain with Waterproof Plug Post-Decontamination

T-Chain | Sensor, Buoy, Temperature Chain (Figure 100):

- **0351720301** D03CA1 SUGG
- **0351720302** D03CA2 BARC
- **0351720311** D03RA1 FLNT
- **0351720501** D05CA1 CRAM
- **0351720502** D05RA1 LIRO
- **0351720811** D08RA1 BLWA
- **0351720812** D08RA2 TOMB
- **0351720901** D09CA1 PRPO
- **0351720902** D09RA1 PRLA
- **0351721801** D18RA1 TOOK



Figure 101. MET Canister and Profiler Canister (NOTE: DISREGARD GREEN GROUND WIRE – KEEP GROUND WIRE AT DOMAIN)

Profiler & MET Canister | CR1000 Data loggers (Figure 101)

Cap and coil canisters and place in an ESD bag and pelican case for shipping/handling. Keep the green ground wire at the Domain.

PRO TIP: Please be aware the radio configuration is site-specific. If sites find issues with data transferring to the Aquatic Portal when reinstalling the canisters, a different radio configuration may be the root cause. Use AD [12] to reconfigure the radios.

Please remove all arachnids/insects and any biofouling from buoy instruments prior to packing and shipping. Conduct decontamination on all sensors returning to HQ per [AD \[08\]](#).

For any Non-CVAL initiated sensor returns, please notify CVAL of the return.

For Sensor Refresh, package sensor items via packaging from CVAL HQ with packing list or per guidance via the Issue Management System and return to the NEON project HQ using the following address:

BATTELLE ECOLOGY, **ATTN: CVAL**
1685 38TH STREET, SUITE 100
BOULDER, CO 80301

Only include sensors/subsystems for refresh. Additional equipment must ship separately as they may require attention from other NEON HQ departments. Sensor refresh shipments go direct to CVAL. If sensors are shipping to HQ to address a trouble ticket, per guidance via the Issue Management System, return to the NEON project HQ using the following address:

BATTELLE ECOLOGY, **ATTN: REPAIR LAB**
1685 38TH STREET, SUITE 100
BOULDER, CO 80301

6.4 Sensor Refresh Record Management of Assets

In addition to the physical movement of devices, the sensor refresh process requires dedicated and accurate record management of asset movement and location.



Title: NEON Preventive Maintenance Procedure: AIS Buoy		Date: 03/08/2022
NEON Doc. #: NEON.DOC.004613	Author: M. Cavileer, G. Simonds, R. Willingham	Revision: C

6.4.1 NEON Asset Management and Logistic Tracking System Requirements

Technicians must update the instrumentation records via the NEON’s project Asset Management and Logistic Tracking System (MAXIMO). NEON HQ must maintain accurate record keeping on the location, date, and time offline of an instrument to ensure NEON HQ, Computer Infrastructure, Data Products, and CVAL are aware to apply the correct algorithms, calibrations, and processing factors. Reference RD [12] for additional information on Sensor Refresh administrative procedures. Ensure the CFG location reflects the current site of the sensor. All devices leaving a CFGLOC must move to SITE first, then TRANSIT/DxxSUPPORT.

 **Note: In general, to minimize errors for CI, all devices leaving a CFGLOC must move to SITE first, then TRANSIT/DxxSUPPORT.**

After installation of the sensors, verify sensor data state of health (Data Product) in the [SAS report](#) the next day (this report updates every 24 hours). Validate sensor data stream(s) and LO data is good (in green). Reference [AD \[12\]](#) for Test Case: NEON Data Streams for a list of operational data streams to expect post-Sensor Refresh.

6.4.2 Remote Connection Program Information Requirements

This procedure primarily supports the use of a local connection to the AIS Buoy (directly to the Buoy from your laptop). If there is ever a need to access LoggerNet™ (Profiler and MET Software) remotely (from the Domain or HQ), ENG must shut down the RTU program (software that collects and transmits the data from the AIS Buoy to HQ). The RTU program uses the same port we would use to connect remotely to communicate with LoggerNet™. Submit a ticket via the NEON Issue Management/Reporting System to coordinate this action with attention to the Software Engineers in the NEON HQ, Engineering Department.



Title: NEON Preventive Maintenance Procedure: AIS Buoy		Date: 03/08/2022
NEON Doc. #: NEON.DOC.004613	Author: M. Cavileer, G. Simonds, R. Willingham	Revision: C

7 ISSUE REPORTING OUTPUTS

FOPS must report issues encountered while conducting preventive maintenance in the NEON project Issue Management/Reporting System. To ensure a quick response and remedy to an issue, please include as much information and detail, as possible. This includes, but is not limited, to the following:

- Domain and Site name
- Date and Time
- Technician Full Name
- Issue Narrative (detailed narrative of the issue, specific location of issue on aquatic infrastructure, relevant 2nd/3rd order effects to infrastructure, possible cause [e.g., weather event, obstruction, human activity])
- Multiple Photographs (to capture vantage points/perspectives for remote diagnostic)
- Provide Part Number/Manufacturer Information, EPROM ID, Asset Tags, IP/MAC Address, etc.
- Provide Diagnostic Information (from firmware, if applicable), such as error codes, values, etc. Provide screenshots.

7.1 Preventive Maintenance Documentation

Maintain a permanent record of site preventive maintenance work. The degree of detail depending on the operating conditions. In any event, it is a valuable reference for subsequent maintenance work and for operation of the AIS Buoy. Include the occurrence of preventive maintenance, the condition of equipment and any corrective actions or events requiring issue reporting. **Table 10** is a template of the minimum standard. Technicians are welcome to expand upon this template.

Table 10: AIS Buoy Metadata Output Checklist

Issue Reporting Datasheet		
Datasheet field	Entry	
NEON Site Code		
Maintenance Date		
Maintenance Technician		
Preventive Maintenance	Issue Noted	Issue Summary
AIS Buoy Infrastructure – Condition Check	<input type="checkbox"/>	
Winch Assembly – Condition Check	<input type="checkbox"/>	
Mooring System – Condition Check	<input type="checkbox"/>	
Buoy Instrumentation – Condition Check	<input type="checkbox"/>	
Cables & Connectors - Condition Check	<input type="checkbox"/>	
Other Specific Checks/Inspections or Item to Note	<input type="checkbox"/>	
D03 FLNT: Peristaltic Pump System Inspection/Condition Check	<input type="checkbox"/>	



Title: NEON Preventive Maintenance Procedure: AIS Buoy		Date: 03/08/2022
NEON Doc. #: NEON.DOC.004613	Author: M. Cavileer, G. Simonds, R. Willingham	Revision: C

Issue Reporting Datasheet		
D03 FLNT: Fixed Underwater Sensor Tubes Condition Check	<input type="checkbox"/>	
Environmental Information	<input type="checkbox"/>	
Notes		

For AIS Buoy corrective actions, ensure proper tracking of the asset via the NEON issue management and tracking system (e.g., JIRA or ServiceNow) to establish a chain of custody of the asset between Engineering Repair Laboratory and CVAL.

1. Ship all defective equipment/assets with a red “Rejected” tag. **Figure 102** displays the minimum information requirements for each tag.



Figure 102. Red Rejected Tag for Defective Assets (MX104219)



8 APPENDIX A: CHECKING FOR HUMIDITY IN THE PROFILE/MET CANISTERS

1. Connect a laptop to the Controller Assembly using the diagnostic cable. Attach the buoy serial cable to the RS-232 diagnostic port on the profiler (lower) canister and to a laptop (using a USB to serial adapter). **Figure 47** displays the RS-232 diagnostic port in green.
2. Start LoggerNet™ and connect to the canister. Click **“Connect”**.
3. Click on the **“Num Display”** in **Figure 103**.

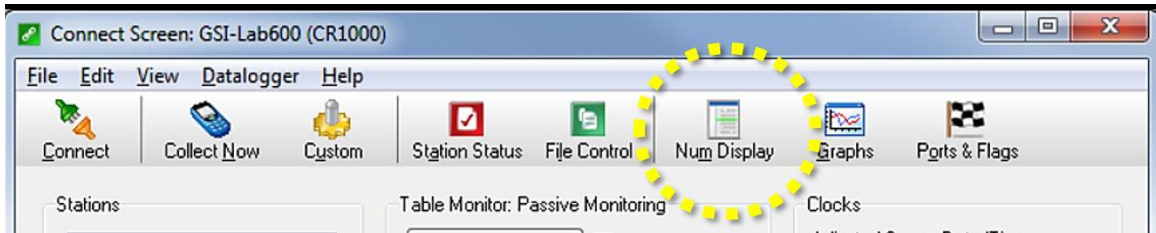

Figure 103. Click Num Display to Load the Configuration Files

4. Click **“Load”**.
5. Use the following text files to load into software (double click on Profiler Display and Met Display files below⁴):



Profiler_Display1.ndc



Met_Display1.ndc

6. The values are **“RH_Avg”**.

Per YSI, the data should display a downward trend once the desiccant is sealed within the canisters. Over time, a leak may present itself in the data in the shape of a rising curve. This may also mean the desiccant requires a refresh or replacement (if no leak is present).

⁴ If Technicians are unable to access these text files, or would like to inquire if a new version is available or any known issues with these text files, please reach out to one of the Authors on this document.



Title: NEON Preventive Maintenance Procedure: AIS Buoy		Date: 03/08/2022
NEON Doc. #: NEON.DOC.004613	Author: M. Cavileer, G. Simonds, R. Willingham	Revision: C

9 APPENDIX B: AIS BUOY INSTRUMENT OPERATING/STORAGE TEMPERATURES

Table 11 is a summary of environmental parameters for specific equipment on the AIS Buoy.

Table 11. AIS Buoy Equipment Environmental Parameters*

INSTRUMENT	OPERATING TEMPERATURE	STORAGE TEMPERATURE	OTHER INFORMATION
M650H BEACON	-45 to 124 °F (-43 to 51 °C)	-45 to 176 °F (-43 to 80 °C)	Technical Support Email: customerservice@carmanah.com Toll Free: 1.877.722.8877 (US & Canada)
GARMIN GPS16X-HVS GPS	-30° to +80°C operational	-40° to +80°C storage	
T-CHAIN			Requires no less than 9 VDC and no greater than 20 VDC
KIPP & ZONEN PAR, PQS-1	-40 to 80 °C	-30° to +70° C	
DIGITAL COMPASS, HMR3300	-20°C to +70°C	-55°C to +125°C	Inside PVC Canister.
RM Young Heavy Duty Wind Monitor-HD-Alpine (2D Wind) MODEL 05108-45	-50 to 60°C		Sensor weight: 1.0 kg (2.2 lbs.) Shipping weight: 2.3 kg (5 lbs.)
UNDERWATER PAR BAROMETRIC PRESSURE		-40 to +60C	Firmware Version 1.13, requires calibration
NET RADIATION, NR01		-40° to +80° C	
SDM-SIO1 SERIAL INPUT/OUT MODULE FOR CAMPBELL DATA LOGGERS (IN CANISTER WITH CR1000S)	-25°C - +50°C		Humidity: 0% - 95% (non-condensing)
EXO2 MULTISONDE	- 5 to +50°C	-20 to +80°C	Weight w/ battery 7.90 lb.
AIS BUOY ANTENNA (ON T-FRAME)	-40° C to 85°C		The cable with the connector for the Antenna has an operating range of - 40°F to 165°F and Storage Temperature -65°F to 175°F
MASTERFLEX L/S COMPACT 12-VDC DRIVE; 540 RPM PUMP DRIVE (D03 FLNT ONLY)	0° to 40°C	-20° to 60°C	Humidity (non-condensing): 10% to 90%, Chemical Resistance: Exposed material is painted CRS, aluminum and plastic Weight: 4.1 kg (9 pounds)

*This table lists information that was available at the time of writing this document. It does not include all the equipment on the AIS Buoy.



10 APPENDIX C: CONNECTING TO THE SUNA ON THE BUOY

This procedure provides instructions for AIS Technicians to connect to the SUNA V2 Nitrate Analyzer on the AIS Buoy. ***Please read this procedure prior to conducting it in the field; disconnecting from the SUNA requires disconnecting from the software FIRST before unplugging the cable from the SUNA. NEVER UNPLUG THE SUNA WITHOUT DISCONNECTING FROM SUNACOM SOFTWARE FIRST!***

1. At the Domain Office, download the following SUNA V2 Software, [SUNACom Version 3.0.11/Seabird UCI](#) and an [FTDI Driver](#) (if your USB does not have an FTDI Chip) onto a laptop accompanying you in the field. If you use a loaner laptop, please download the FTDI Driver with the SUNACom software.
2. Collect the following materials to complete this procedure in the field: SUNA V2 Cable (Connects to Laptop via USB, the SUNA V2 sensor, and power connection), fully charged Laptop with SUNA V2 Software, gloves to lift dual PAR SUNA mount out of the water, and knee pads to kneel on the Lake Buoy floating deck (as necessary).
3. Connect the SUNA V2 Cable USB into your laptop, the Amphenol power connection into the Radio box where the SUNA V2 derives its power on the Lake Buoy, and the sensor pin connection to the SUNA V2 instrument. The SUNA may remain in the cage for this process on the dual PAR SUNA mount.
 - a. There are no issues directly unplugging/plugging into the power connection (this is not like handling a Grape).

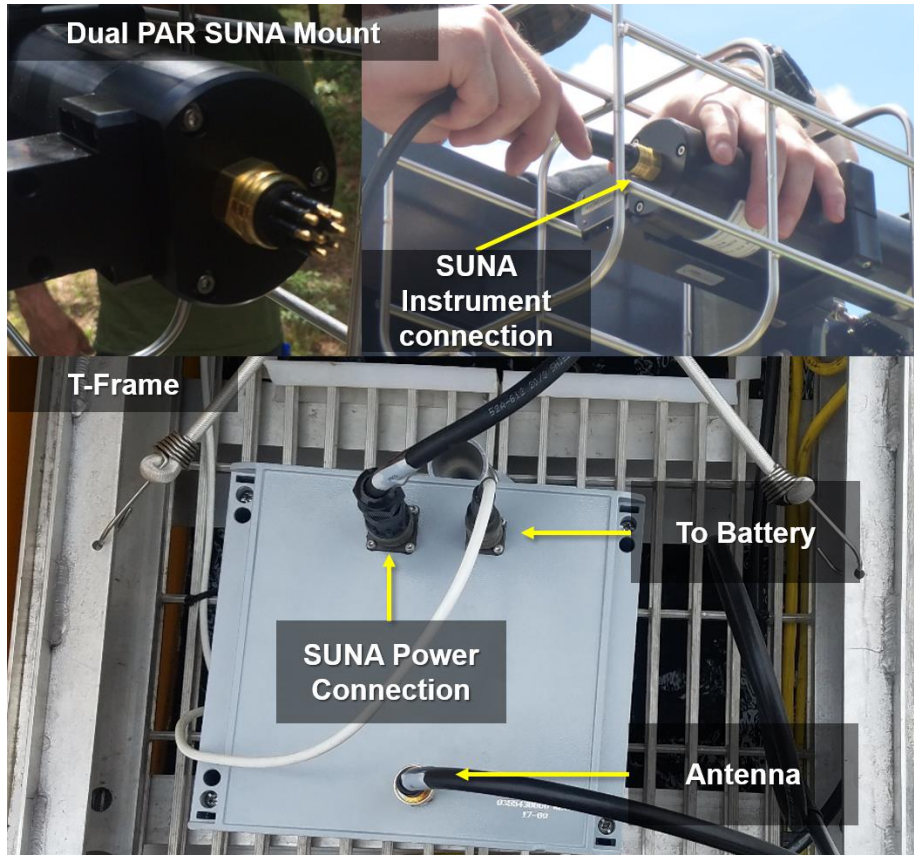

Figure 104. SUNA Instrument and Power Connections on the AIS Buoy

4. Open the **SUNAc**om/UCI software on your laptop.
5. Select the **“Connect”** icon on the left hand side of the window (see **Figure 105** and **Figure 106**).

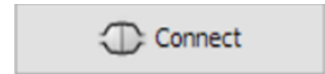

Figure 105. "Connect" Icon

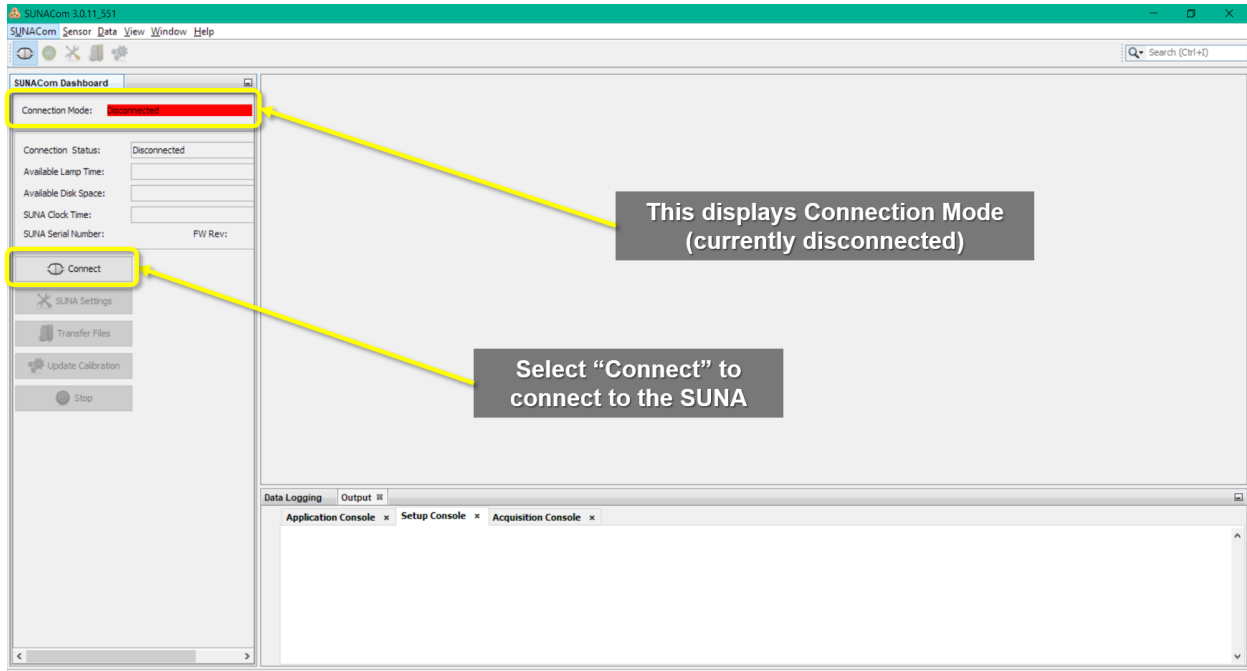

Figure 106. Select the "Connect" Icon (Connection Mode: Disconnected)

6. In the Connect pop-up window, select the Baud Rate from the drop down options (see **Figure 107**).
 - a. Select a Baud Rate of **"115200"** for a SUNA on a Lake Buoy.
 - b. Select a Baud Rate of **"57600"** for the SUNA at an S-2.
 - c. Select **"COM27"** for both Baud Rates and click **"Connect"**.

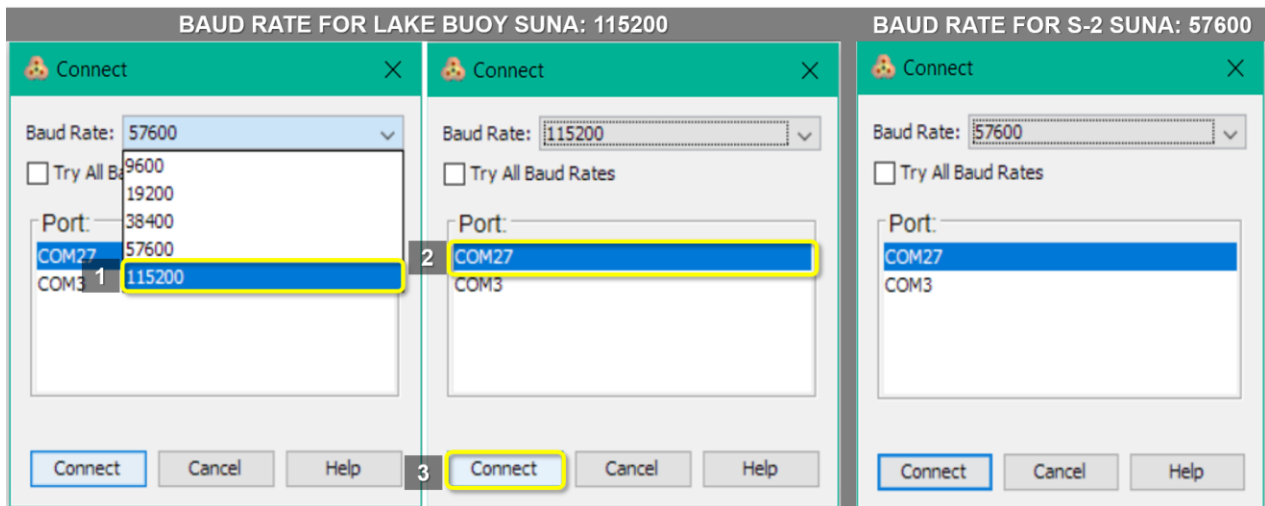

Figure 107. SUNA Baud Rate for AIS Buoy and In-Stream (S-2)

7. The **Connection Mode** under the **SUNACom Dashboard** tab in the upper left hand corner of the window changes to yellow and the **"Setup Console"** tab starts displaying characters (see **Figure 108**).

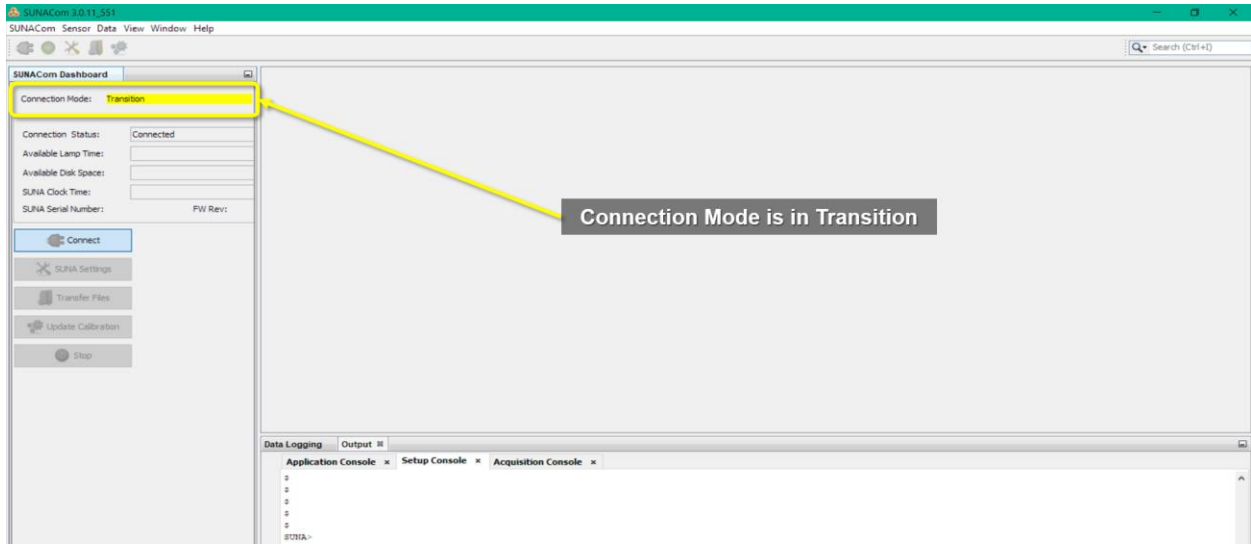

Figure 108. Connection to SUNA is in Transition

8. The connection is successful with the “Setup Console” tab displays “SUNA>” and connection data is continuously scrolling up, and the **Connection Mode** is green (see Figure 109).

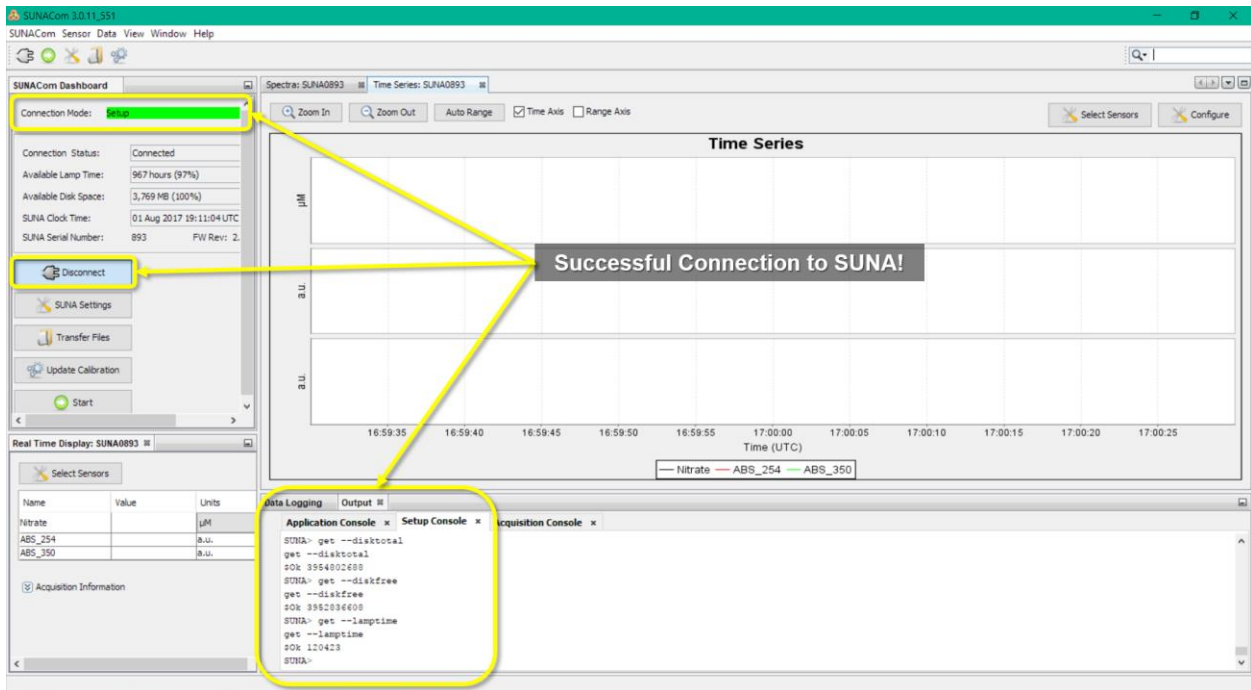

Figure 109. Successfully Connected to the SUNA

9. In the upper right hand corner, select the “Sensor” dropdown (see Figure 110).
 - a. Select “Advanced”.
 - b. Select “Command Terminal”

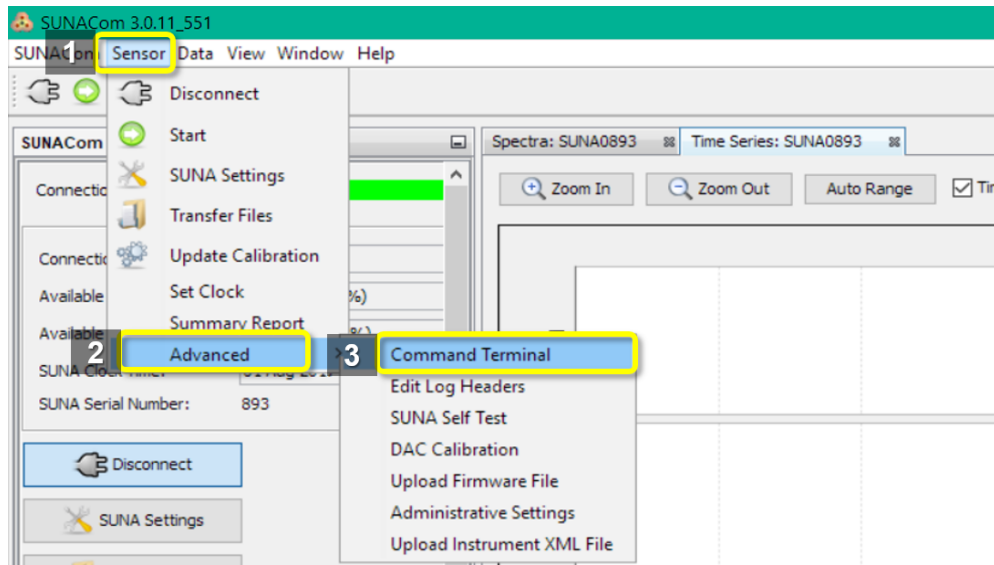

Figure 110. Select "Sensor>Advanced>Command Terminal" from Dropdown

10. This opens a "Command Terminal" window. Select "get --cfg" and click "Submit". This loads your SUNA configuration settings (see Figure 111).

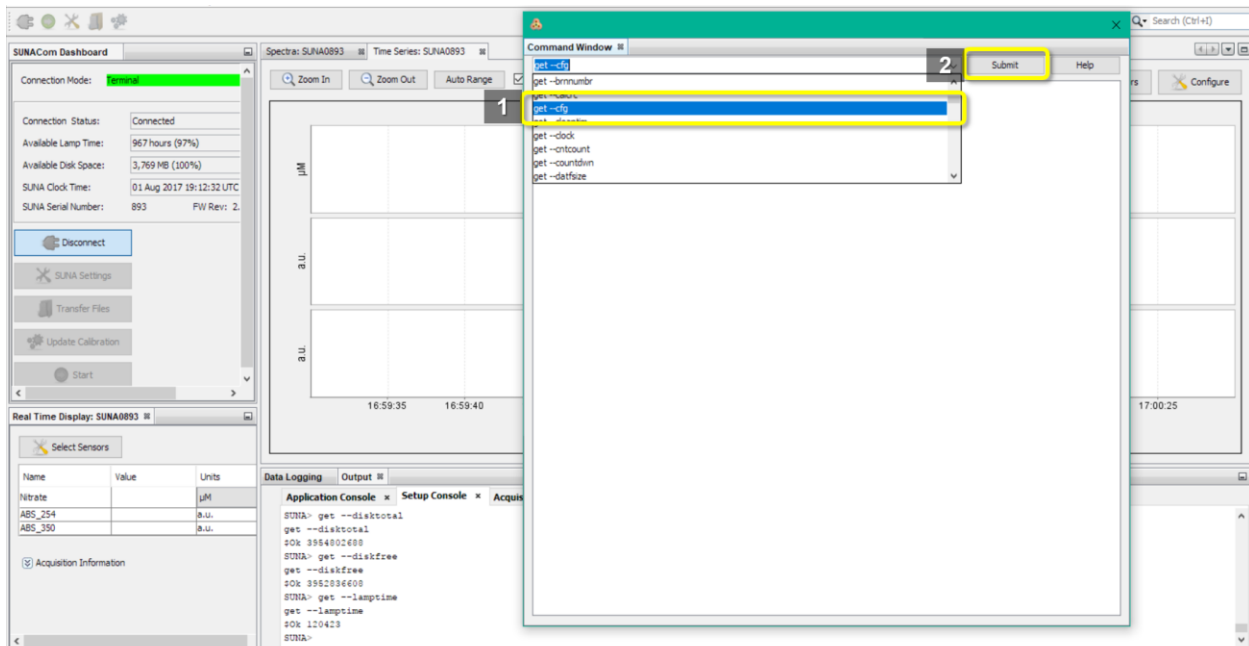

Figure 111. Command Terminal Window "get -- cfg"

11. Compare/cross-reference the SUNA configuration list in AD [05], the C3 for the AIS Buoy (Table 25).

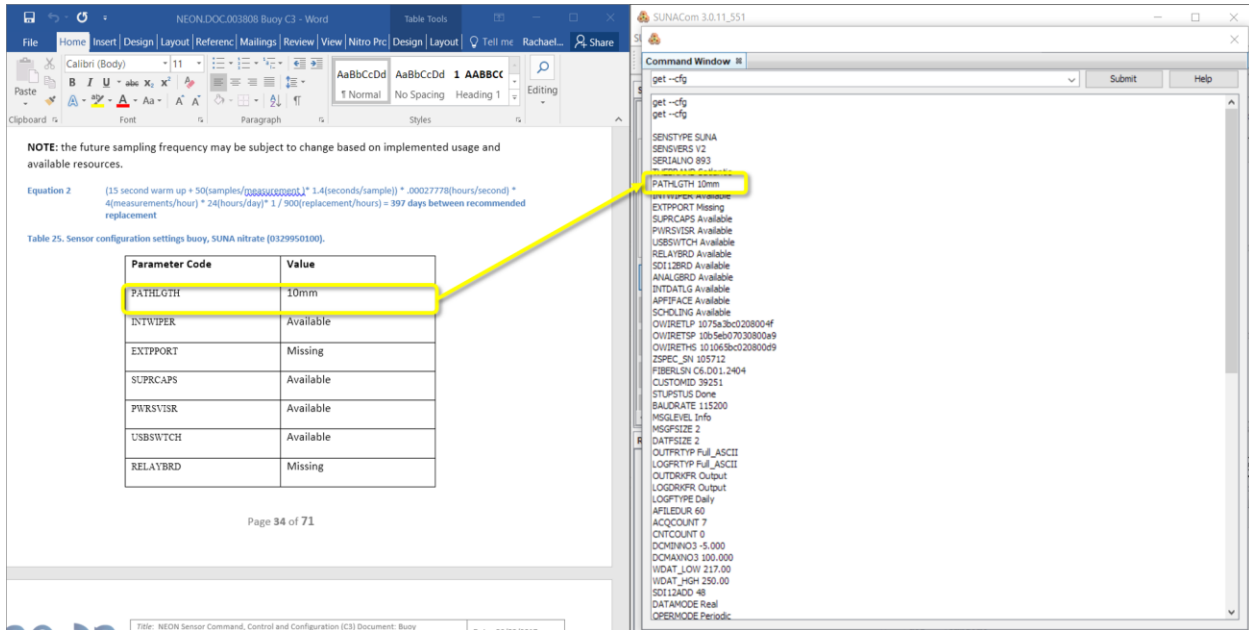

Figure 112. Verify SUNA Configuration Settings are Correct using the C3

12. In the event the SUNA configuration settings do not match, correct it in the **Command Window**.
 - a. For example, if **"TEMPCOMP"** does not match the C3, select the dropdown in the **Command Window** and find the **Parameter Code** (see **Figure 113**).
 - b. Select the **Parameter Code** **"tempcomp [value]"**.
 - c. Modify the **Parameter Code** directly in the **Command Window** dropdown field. Delete the area with the brackets and replace it with the **Value** from Table 25 **"tempcomp off"**. If the brackets remain, the software does not apply the change and throws an error.
 - d. Click **"Submit"**.

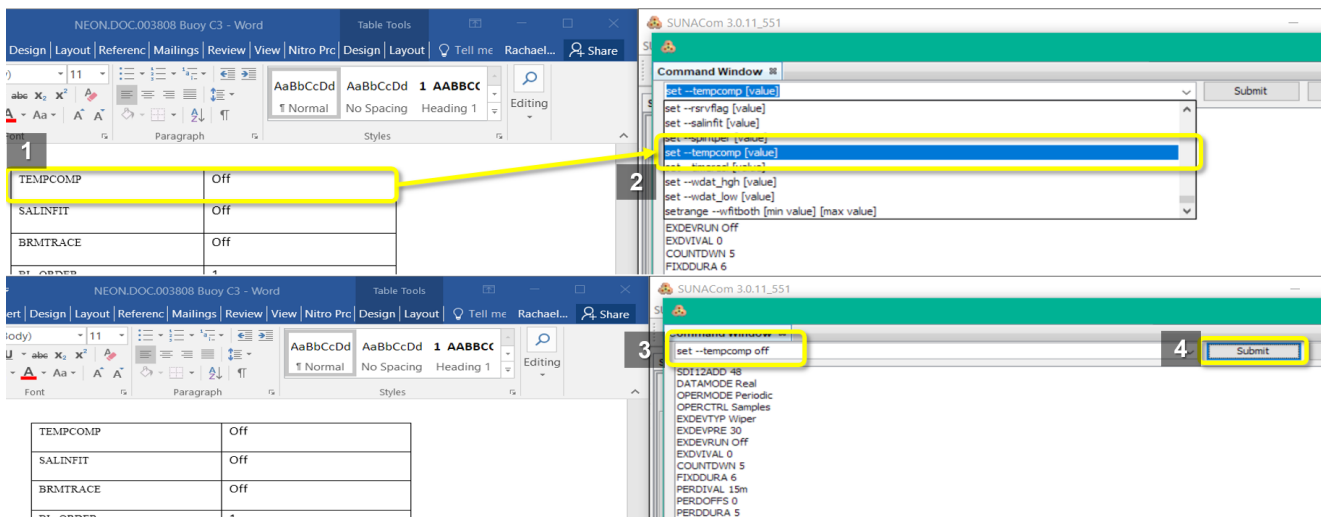

Figure 113. Change "tempcomp [value]" to "tempcomp off" Example

13. The changes display at the bottom of the screen as a confirmation (see **Figure 114**).

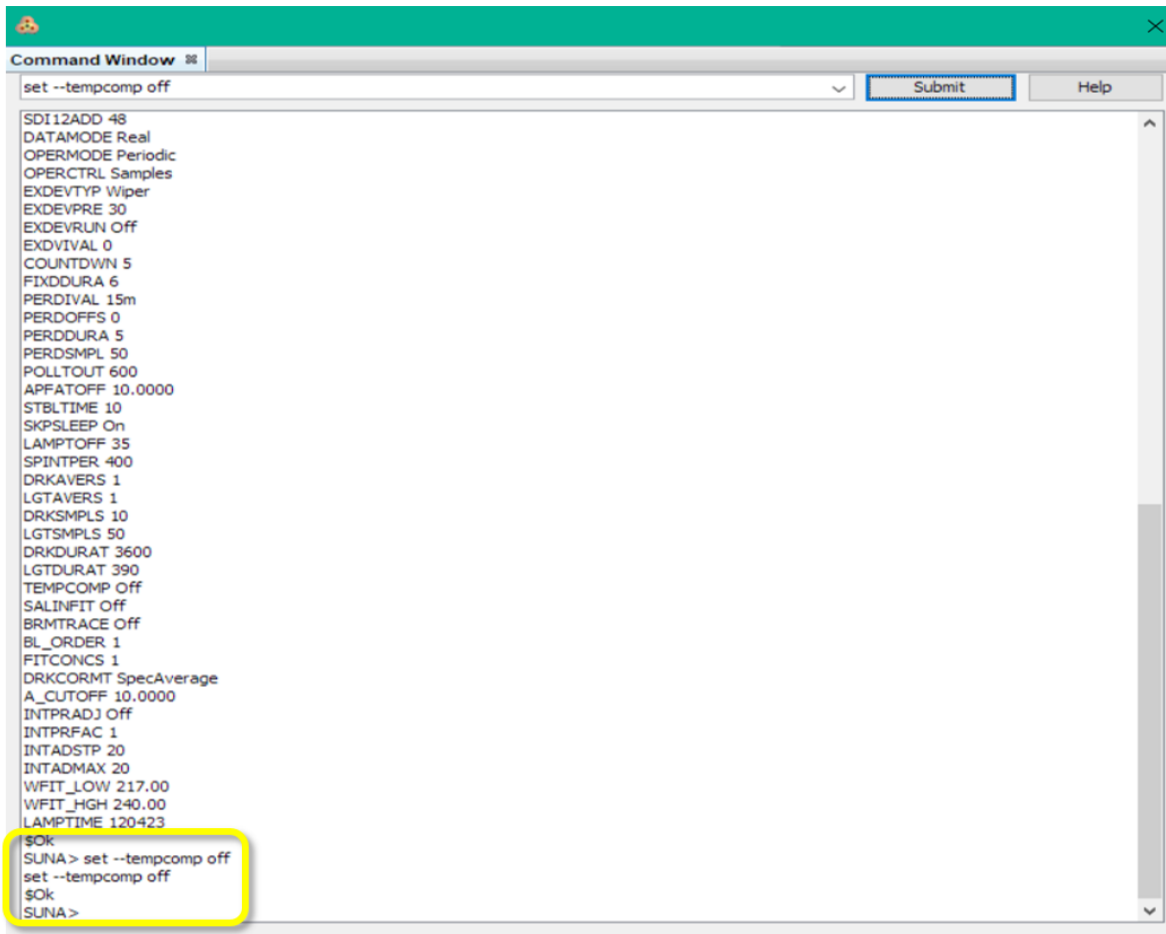

Figure 114. "tempcomp off" Changes Confirmed

14. Some parameters may not appear on the list. Add custom parameters in the **Command Window** by using "**Set – CustomID**", where "CustomID" represents the parameter. For example, type in the Command Window "**Set – EPROMID**" to add EPROM ID as a parameter or add, "**Set – STBLTIME 10**" to add **STBLTIME**, if it is not available on the list of parameters and click "**Submit**".
15. Reload the SUNA configuration by selecting "**-- get cfg**" and click "**Submit**" to see the changes in the SUNA configuration file.
16. To disconnect from the SUNA configuration via the **Command Window**, click the "**X**" in the upper right hand corner of the **Command Window**.
17. To disconnect from the SUNA instrument, click "**Disconnect**" under the **SUNACom Dashboard** section of the main program window (see **Figure 115** and **Figure 116**).

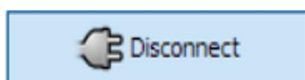

Figure 115. Click "Disconnect" Icon

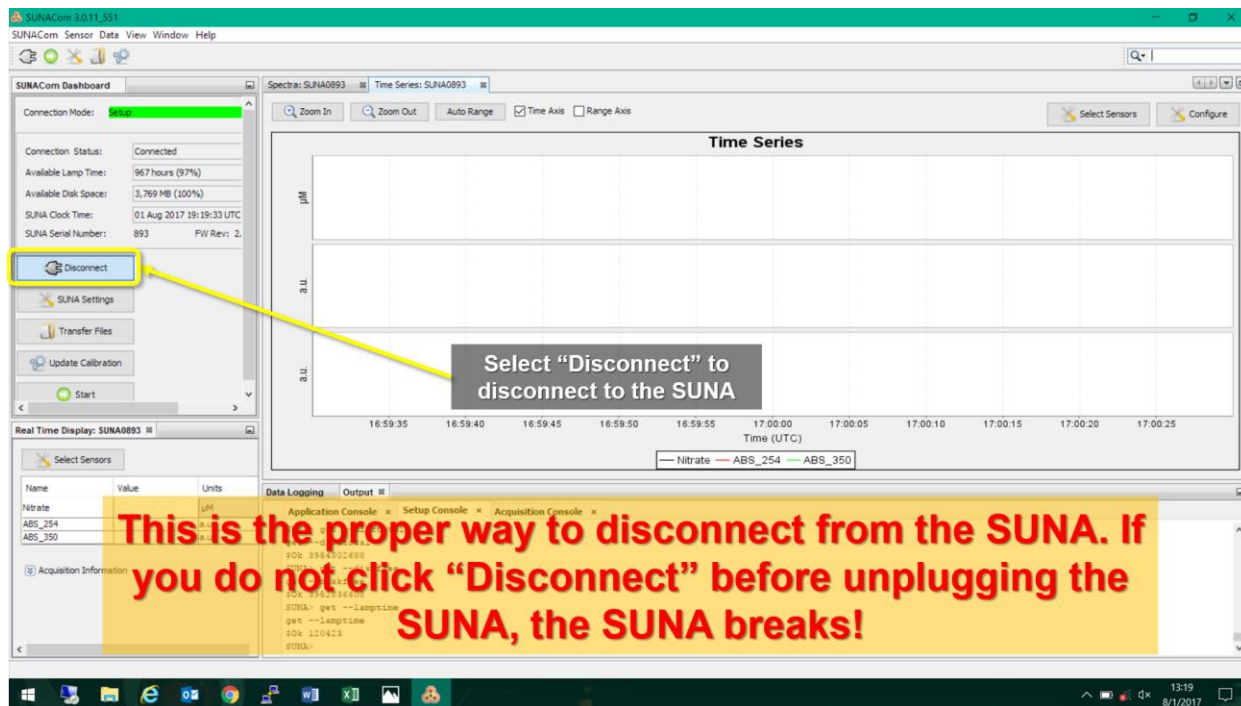

Figure 116. Click "Disconnect" to Properly Disconnect from the SUNA

- 18. When the SUNAcom software displays the Connection Mode as red, you can safely unplug the cable from the SUNA instrument (see Figure 117).

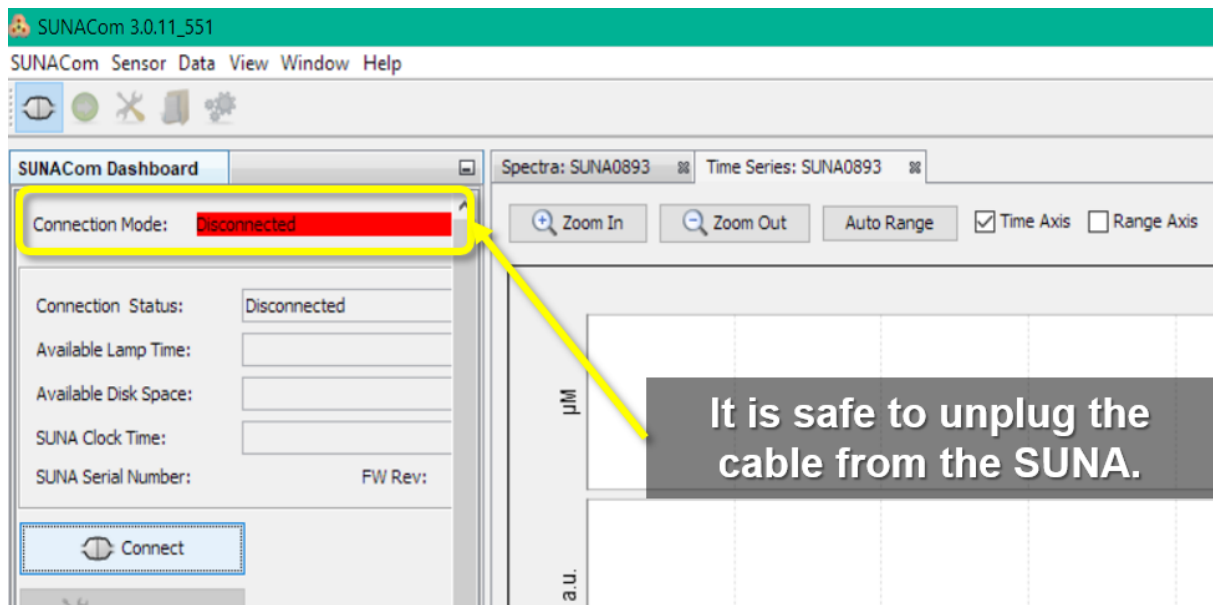

Figure 117. Safe to Unplug Cable from SUNA



11 APPENDIX D: SETTING THE SUNA INTERNAL CLOCK

The SUNA internal clock drifts over time, especially the longer the instrument has been in the field. It must be within +/- 30 seconds Universal Time Coordinated (UTC) for the Location Controller (LC) to collect data from the SUNA via radio link. This procedure provides instructions for AIS Technicians to correct for drift by synchronizing the SUNA internal clock to within +/- 30 seconds UTC. ***Please read this procedure prior to conducting it in the field; disconnecting from the SUNA requires disconnecting from the software FIRST before unplugging the cable from the SUNA. NEVER UNPLUG THE SUNA WITHOUT DISCONNECTING FROM SUNACOM FIRST!***

1. Select the “Sensor” dropdown and select “Set Clock”.

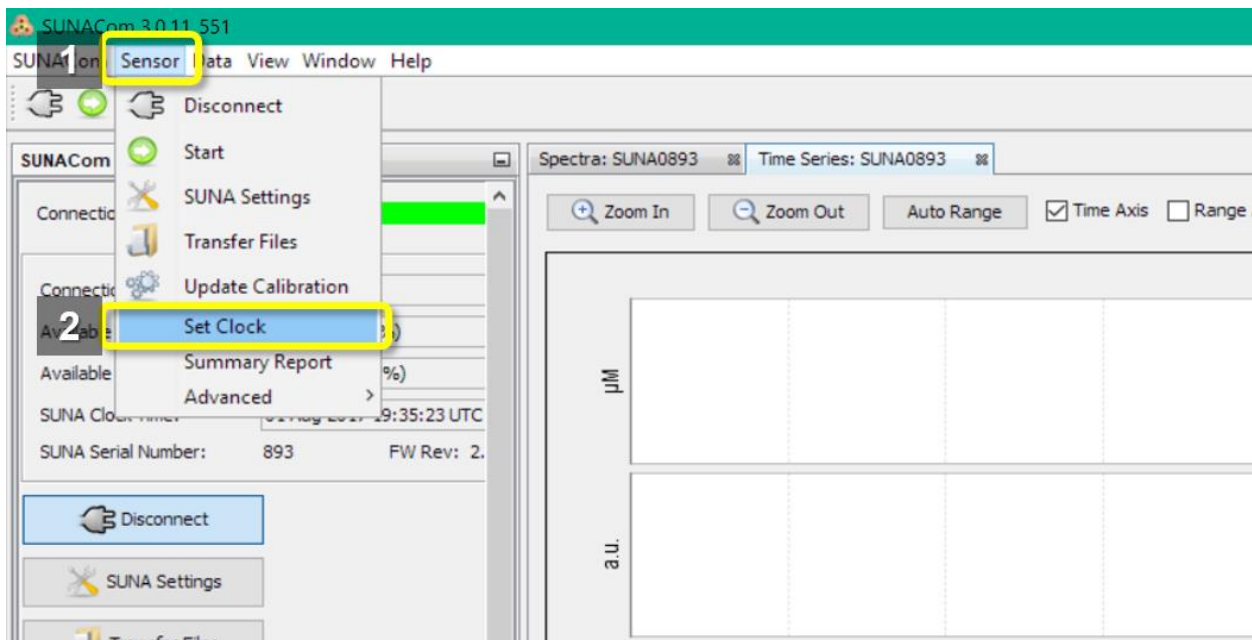

Figure 118. Select "Sensor" and "Set Clock"

2. A **Set Clock** window opens. Click “Sync Time” (the SUNAcom software automatically converts your computer time to UTC). See **Figure 119**.

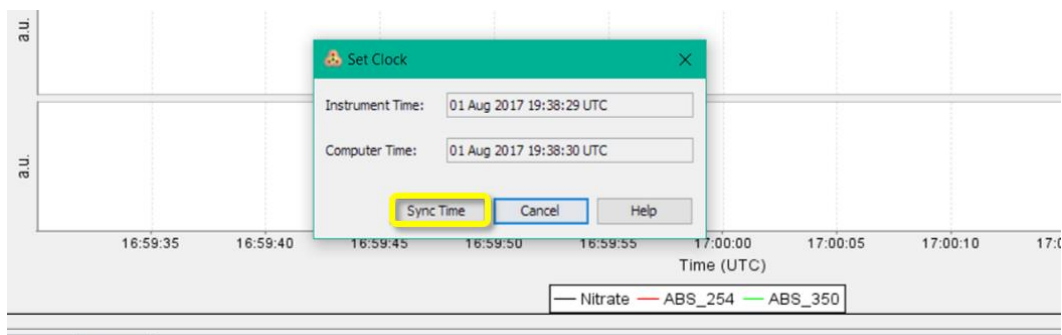

Figure 119. Click "Sync Time" to Synchronize SUNA Internal Clock



Title: NEON Preventive Maintenance Procedure: AIS Buoy		Date: 03/08/2022
NEON Doc. #: NEON.DOC.004613	Author: M. Cavileer, G. Simonds, R. Willingham	Revision: C

12 DOMAIN 03 FLNT: FLINT RIVER PREDICTION RESOURCES FOR MAINTENANCE AND/OR ANTICIPATE POTENTIAL FLOODS/DROUGHTS

PREPARED BY	ORGANIZATION	DATE
Nick Harrison	AIS SCI	02/26/2018

This section aims to support D03 FOPS in forecasting river levels at FLNT and/or to maintain expectations for site visits. At the end of this section a list of resources are available for reference.

AIS Science compiled stage crest data (Table 12, Figure 120) and conducted a flood frequency analysis (Table 13, Figure 121) using annual peak flow data measured at the USGS Flint River station at Newton (Station 02353000, located approximately 15 miles upstream of D03 FLNT AIS site). Discharge at a gage height of 33.00 ft. (~10.00 meters) is estimated to equal approximately 59,000 cubic feet per second (cfs) at the USGS station. A flow event of this magnitude is associated with a return interval of 10-25 years, as indicated by the flood frequency analysis. In other words, we can expect that there is about a 4-10% chance that the 33.00 ft. mark on the USGS gage will be overtopped in a single given year. Over time, a relationship will develop between streamflow measurements at the USGS gage and at D03 FLNT that will improve our ability to predict streamflow within the NEON monitoring reach.

Table 12. Stage Crest Data

Date	Crest (ft.)	Date	Crest (ft.)
1/24/2017	18.07	3/11/1971	30.3
4/8/2016	20.3	4/4/1970	28.8
1/3/2016	32.54	3/9/1966	34.9
2/3/2010	24.96	1/2/1965	25.1
4/5/2009	32.05	4/15/1964	30.2
3/12/1998	36.44	3/4/1961	27.7
7/13/1994	45.25	4/8/1960	30.9
3/7/1991	24.32	5/10/1953	25.7
3/25/1990	28.81	3/28/1944	31.7
3/16/1980	24.5	3/27/1943	29.6
3/3/1979	25.3	3/20/1942	26.8
2/2/1978	26.6	3/7/1939	25.7
3/22/1975	28.9	4/15/1938	25.6
3/11/1971	30.3	1/21/1925	41.3

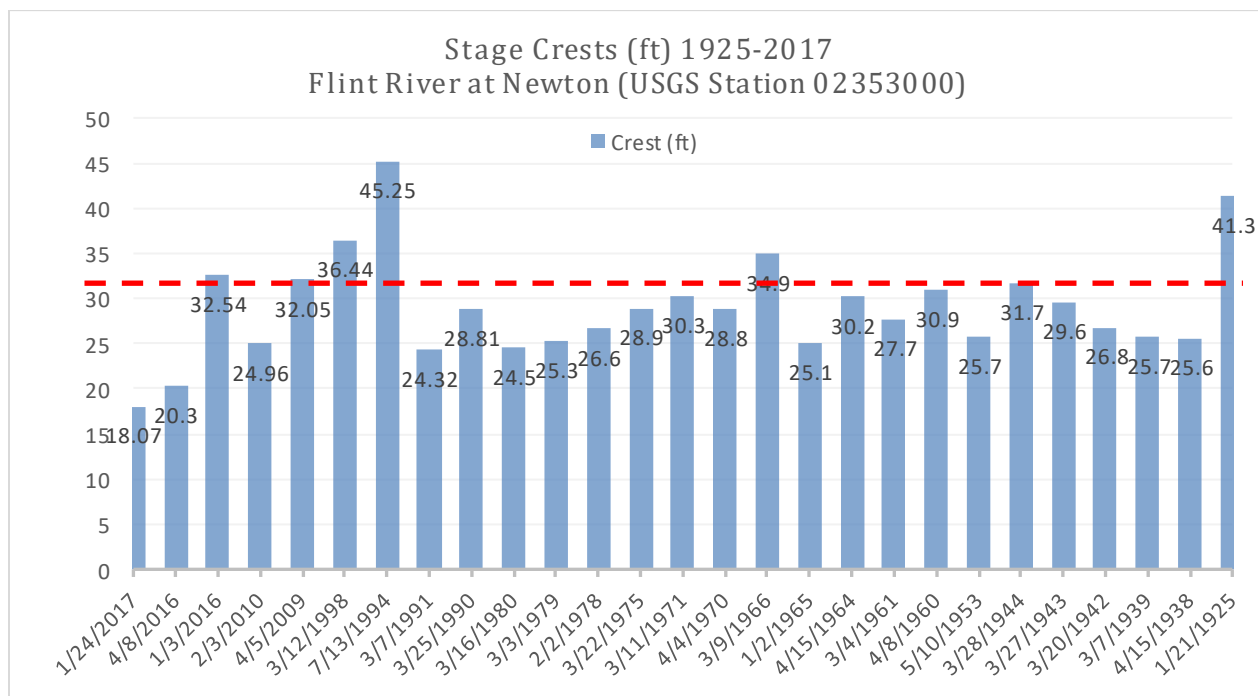

Figure 120. Stage Crest Data (ft.) 1925-2017 USGS Station #02353000 FLNT at Newton (Red Line is Gage Height of 33.00 ft.)



Table 13. Exceedance probability table for stream discharge at USGS Station #02353000, Flint River at Newton. Green rows highlight exceedance probability values associated with a stage level of >33.00 feet.

Exceedance Probability	Return Interval (Years)	BULL.17B Estimate (cfs)	Systematic Record (cfs)	95% Lower (cfs)	95% Lower (cfs)
0.995	1.0	6870	6741	5420	8286
0.990	1.0	7952	7836	6399	9451
0.950	1.1	11750	11680	9939	13460
0.900	1.1	14390	14360	12460	16220
0.800	1.3	18290	18320	16220	20310
0.667	1.5	22780	22850	20520	25100
0.500	2.0	28530	28630	25910	31430
0.429	2.3	31270	31370	28410	34540
0.200	5.0	43630	43660	39270	49230
0.100	10.0	54050	53920	48000	62290
0.040	25.0	67540	67050	58920	79850
0.020	50.0	77750	76890	66980	93540
0.010	100.0	88060	86740	74990	107700
0.005	200.0	98520	96660	82980	122300
0.002	500.0	112600	109900	93610	142300

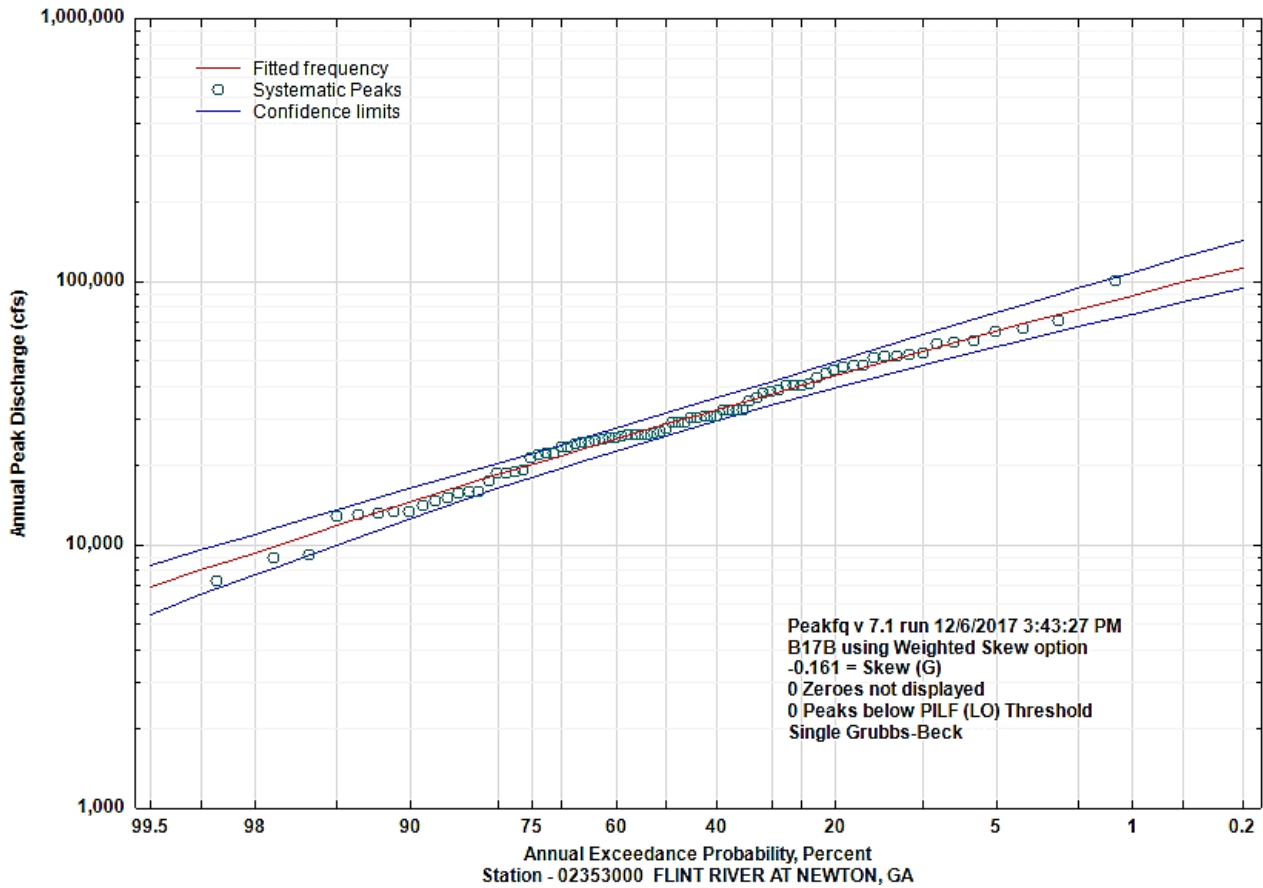

Figure 121. Annual exceedance probability (%) vs. peak discharge (cfs), at USGS Station #02353000, Flint River at Newton. Graph generated using PeakFQ software (USGS).



Title: NEON Preventive Maintenance Procedure: AIS Buoy		Date: 03/08/2022
NEON Doc. #: NEON.DOC.004613	Author: M. Cavileer, G. Simonds, R. Willingham	Revision: C

12.1 Flood Prediction Resources for D03 FLNT

The National Oceanic and Atmospheric Administrations (NOAA) and the National Weather Service (NWS) provide forecast model results that D03 FOPS may utilize in order to gauge the likelihood that water level will exceed 33.00 feet at the USGS station upstream of D03 FLNT. Data provided in the following links are also useful to forecast river conditions prior to biweekly maintenance activities.

The Flint River at Newton weekly exceedance probability for stage levels:

http://water.weather.gov/ahps2/probability_information.php?wfo=tae&qage=newq1

The above link provides the most relevant information to determine whether to pull the AIS Buoy. During flood season, at the beginning of each week, check the probability associated with a stage exceedance of 33.00 feet using the stage forecast model for the USGS station. If the probability of a stage exceedance of 33.00 feet (10.00m) is greater than 50%, notify AIS Science immediately. Science staff will monitor the forecast and advise FOPS on how to proceed. ***Reference the Domain 03 Safety (EHS) Plan and/or consult with the NEON Safety Office directly about entering the water when the probability of a 10m stage level is greater than 50%.***

USGS Gaging Station on the Flint River at Newton:

https://waterdata.usgs.gov/nwis/uv?site_no=02353000

The above link provides real-time hydrology data measured at the USGS station at Newton. Use this resource to estimate current conditions upstream of D03 FLNT. As continuous stage data is measured at D03 FLNT over time, a relationship will be established between the two stations that will improve flood forecasting and decision-making at the Domain level.

Southeast River Forecast Center: <http://www.weather.gov/serfc/>

The above link provides an overall assessment of stage measured across the southeastern United States. FOPs may find this information useful in order to assess and compare regional river conditions.



Title: NEON Preventive Maintenance Procedure: AIS Buoy		Date: 03/08/2022
NEON Doc. #: NEON.DOC.004613	Author: M. Cavileer, G. Simonds, R. Willingham	Revision: C

13 SOURCES

Cole-Palmer Instrument Company, LLC. About Peristaltic Pumps. <https://www.coleparmer.com/tech-article/about-peristaltic-pumps>. August 31, 2017.

Hunter, Allen (YSI). NEON Mechanical Training Presentation PPT. May 2017.

Hunter, Allen (YSI). NEON Mooring Preventive Maintenance Recommendations Phone Discussion with Madeline Cavileer. June 29, 2017.

Harrison, Nick (BEI Research Scientist, Hydrologist). Estimating stage events > 10M at D03 FLNT. December 6, 2017.

Hunter, Allen (YSI). RE: Question for Buoy Storage Email. August 02, 2017.

Kelly, Kenneth (YSI). RE: RH% Threshold in Data Logger Canisters Email. September 25, 2017.

R.M. Young Company. *Maintenance*. Wind Monitor-HD Alpine Model 05108-45 Instructions, Rev. A030513 (PN: 05108-45-90), Pages 2-3.

Scott, Matt and Megan Zopfi. PRPO Buoy Deployment Instructional Document. Feb 02, 2017.

Schroeder, Matt. FOPS and AIS Toolkit Spreadsheet via [SharePoint](#). August 7, 2017.

Simonds, Geoff and Corey Huffman. AIS Integration Photos of D03 FLNT Buoy. N:\Common\SYS\Install Docs Work in Progress 20170619\AIS_Install_Docs\Incoming_Drafts\D03-FLNT

Simonds, Geoff. AIS Post I&V Impact Report D18RA1 TOOK. July 20, 2017.
<file:///N:\Common\IPT\00%20Archive-Released%20Designs\1.%20See%20Agile-AIS-Underwater%20PAR\A-Drawings\UPAR%20CDR%20Slides.pptx>

YSI Incorporated. About the Vertical Profiler Frequently Asked Questions.
<https://www.ysi.com/File%20Library/Documents/FAQs/Vertical-Profiler-FAQs.pdf>

YSI Incorporated. Care, Maintenance, and Storage of YSI 6-Series Probes and Sondes.
<https://www.ysi.com/File%20Library/Documents/Technical%20Notes/T601-Care-Maintenance-and-Storage-of-YSI-6-Series-Probes-and-Sondes.pdf>

YSI Incorporated. *Section 1.3 Getting Started*. Vertical Profiler System (CR1000) Manual, Version 3. December 19, 2011.

YSI Incorporated. *Section 6.4 Maintenance – Servicing Other System Components*. Vertical Profiler System (CR1000) Manual, Version 3. December 19, 2011.

YSI Incorporated. Boat and AIS Buoy Tie-off Graphic. March 15, 2018.



Title: NEON Preventive Maintenance Procedure: AIS Buoy		Date: 03/08/2022
NEON Doc. #: NEON.DOC.004613	Author: M. Cavileer, G. Simonds, R. Willingham	Revision: C

Zopfi, Megan. AIS Winterization: Seasonal Removal of Buoy, Groundwater Well Hibernation. October 04, 2017. [file:///N:\Common\InternalReview\AIS\AIS%20Winterization%20Training%20at%20Toolik\AIS Winterization Training Toolik AK 20170928.docx](file:///N:\Common\InternalReview\AIS\AIS%20Winterization%20Training%20at%20Toolik\AIS%20Winterization%20Training%20Toolik%20AK%2020170928.docx)

ⁱⁱ Cole-Palmer Instrument Company, LLC. MasterFlex Pump Drive Instruction Manual, Model 07533, <https://pim-resources.coleparmer.com/instruction-manual/a-1299-0519.pdf>, Page 4.

ⁱⁱⁱ YSI, 2.3 Install/Remove Guard or Cal. Cup, <https://www.ysi.com/File%20Library/Documents/Manuals/EXO-User-Manual-Web.pdf> Page 24.

^{iv} The YSI project manager verified the D03 FLINT River Buoy design by Allen Hunter, YSI's Mechanical Engineer, is the FINAL design; it is not a preliminary design even though the design has a blue "preliminary" stamp across the front.