

<i>Title:</i> NEON Command, Control, and Configuration: Eddy-covariance Turbulent Exchange Subsystem		<i>Date:</i> 05/26/2016
<i>NEON Doc. #:</i> NEON.DOC.000456	<i>Author:</i> D. Durden, S. Metzger, J. Taylor, H. Loescher	<i>Revision:</i> A

# NEON SENSOR COMMAND, CONTROL AND CONFIGURATION (C3) DOCUMENT: EDDY-COVARIANCE TURBULENT EXCHANGE SUBSYSTEM

PREPARED BY	ORGANIZATION	DATE
David Durden	FIU	2016-04-24
Stefan Metzger	FIU	2015-08-05
Jeff Taylor	FIU	2012-04-14
Hank Loescher	FIU	2012-04-01

APPROVALS	ORGANIZATION	APPROVAL DATE
Andrea Thorpe	SCI	05/25/2016
Vlad Aleksiev	PSE	05/24/2016

RELEASED BY	ORGANIZATION	RELEASE DATE
Judy Salazar	CM	05/26/2016

See configuration management system for approval history.

© 2016 NEON Inc. All rights reserved.

The National Ecological Observatory Network is a project solely funded by the National Science Foundation and managed under cooperative agreement by NEON, Inc. Any opinions, findings, and conclusions or recommendations expressed in this material are those of the author(s) and do not necessarily reflect the views of the National Science Foundation.

<i>Title:</i> NEON Command, Control, and Configuration: Eddy-covariance Turbulent Exchange Subsystem		<i>Date:</i> 0/26/2016
<i>NEON Doc. #:</i> NEON.DOC.000456	<i>Author:</i> D. Durden, S. Metzger, J. Taylor, H. Loescher	<i>Revision:</i> A

## Change Record

REVISION	DATE	ECO #	DESCRIPTION OF CHANGE
A	05/26/2016	ECO-03881	Initial release

### TABLE OF CONTENTS

<b>1</b>	<b>DESCRIPTION.....</b>	<b>5</b>
1.1	Purpose .....	5
1.2	Scope.....	5
<b>2</b>	<b>RELATED DOCUMENTS AND ACRONYMS .....</b>	<b>3</b>
2.1	Applicable documents.....	3
2.2	Reference documents.....	3
<b>3</b>	<b>ASSEMBLY, CSAT AND ELECTRONICS BOX INTRODUCTION (CD00370010 &amp; CD06450000).....</b>	<b>5</b>
3.1	Introduction .....	5
3.2	Overview of sensor configuration.....	6
3.3	Command and control .....	7
3.3.1	Error handling .....	7
3.3.2	Sensor switched heating controls specification.....	7
<b>4</b>	<b>ATTITUDE AND MOTION REFERENCE SYSTEM (CD00370100).....</b>	<b>12</b>

Title: NEON Command, Control, and Configuration: Eddy-covariance Turbulent Exchange Subsystem		Date: 0/26/2016
NEON Doc. #: NEON.DOC.000456	Author: D. Durden, S. Metzger, J. Taylor, H. Loescher	Revision: A

- 4.1 Introduction ..... 12
- 4.2 Overview of sensor configuration..... 13
- 4.3 Command and control ..... 14
- 5 H<sub>2</sub>O AND CO<sub>2</sub> CONCENTRATION MEASUREMENT (CD00380100, CD06640003, CD06640004, CD06450000, & CA07190000) ..... 14**
- 5.1 Introduction ..... 14
- 5.2 Overview of sensor configuration..... 16
- 5.3 Command and control ..... 17
  - 5.3.1 Error handling ..... 22
  - 5.3.2 Sampling mode controls specification ..... 22
  - 5.3.3 Field validation controls specification..... 22
  - 5.3.4 Leak test controls specification..... 24
  - 5.3.5 Intake tube continuous heating controls specification..... 26
  - 5.3.6 Rain cap switched heating controls specification ..... 27
  - 5.3.7 Water trap controls specification ..... 27
- 6 VACUUM PUMP (CD07150000) ..... 29**
- 6.1 Introduction ..... 29
- 6.2 Overview of sensor configuration..... 29
- 6.3 Command and control ..... 29
  - 6.3.1 Error handling ..... 29
  - 6.3.2 Controls specification..... 29
- 7 MASS FLOW CONTROLLERS (CA11460000 & 0341500000)..... 30**
- 7.1 Introduction ..... 30
- 7.2 Overview of sensor configuration..... 30
- 7.3 Command and control ..... 31
  - 7.3.1 Error handling ..... 31
  - 7.3.2 Controls specification..... 31
- 8 GAS CYLINDER PRESSURE SENSORS (CA07160000 & CA07170000) ..... 31**
- 8.1 Introduction ..... 31
- 8.2 Overview of sensor configuration..... 31

<i>Title:</i> NEON Command, Control, and Configuration: Eddy-covariance Turbulent Exchange Subsystem		<i>Date:</i> 0/26/2016
<i>NEON Doc. #:</i> NEON.DOC.000456	<i>Author:</i> D. Durden, S. Metzger, J. Taylor, H. Loescher	<i>Revision:</i> A

8.3	Command and control .....	32
8.3.1	Error handling .....	32
8.3.2	Gas cylinder pressure sensor controls specification.....	32
<b>9</b>	<b>APPENDIX.....</b>	<b>33</b>
9.1	List of Level 0 data product.....	33
9.2	Validation and verification Tests – attitude and motion reference system .....	53
9.3	Acronyms .....	53
9.4	Functions.....	54
9.5	Parameters.....	54
9.6	Subscripts.....	55
9.7	Variables.....	55
<b>10</b>	<b>BIBLIOGRAPHY .....</b>	<b>57</b>
<b>11</b>	<b>CHANGELOG.....</b>	<b>57</b>

Title: NEON Command, Control, and Configuration: Eddy-covariance Turbulent Exchange Subsystem		Date: 0/26/2016
NEON Doc. #: NEON.DOC.000456	Author: D. Durden, S. Metzger, J. Taylor, H. Loescher	Revision: A

## LIST OF TABLES AND FIGURES

Table 1. Current design of sensors and other infrastructure used in the EC-TES, including DGD Agile part number, DGD Agile description, NEON part number and firmware version.....	5
Table 2. List of L0 DPs that are acquired from the SONIC and its heater. Please note that the heater flag and its associated L0 DP are communicated and received from DGD CD06450000 (see Sect. 3.3.2). .....	5
Table 3. SONIC default configuration settings.....	6
Table 4. <b>Truth table to control SONIC heater for ice buildup.</b> .....	8
Table 5. List of L0 DPs that are acquired from the attitude and motion reference sensor. ....	12
Table 6. Default configuration settings for the MTi-300-AHRS attitude and motion reference sensor.....	14
Table 7. List of L0 DPs that are produced by the LI-7200. ....	15
Table 8. Infrared gas analyzer default configuration settings. Because these are sensor settings, tolerances are not available.....	17
Table 9. List of L0 DPs related to LI-7200 operation modes and switched rain cap heating.....	17
Table 10. List of settings and corresponding status during the three principal modes of LI-7200 operation.....	20
Table 11. Configuration of the sampling mode. ....	22
Table 12. Configuration of the field validation. ....	24
Table 13. Configuration of the leak testing.....	25
Table 14. Configuration of the continuous intake tube heating.....	26
Table 15. Truth table to control the switched rain cap heater.....	27
Table 16. Truth table to control the water trap.....	28
Table 17. Configuration of the vacuum pump. ....	29
Table 18. Truth table to control the vacuum pump.....	29
Table 19. Sampling and validation mass flow controller configuration settings. ....	30
Table 20. Default sensor configuration settings for the gas cylinder pressure sensor.....	32
Table 21. Truth table for gas cylinder pressure. ....	32
Table 21. Validation and verification configuration settings for the Xsens MTi-300-AHRS. ....	53
Figure 1. The ‘double rotation’, first around the vertical axis $z_m$ (left), then around the new transverse axis $y$ (right). The attack angle $\alpha$ and the azimuth angle $\Psi$ are shown. The transformation for the x-axis progresses from $x_m$ over the intermediate step $x_i$ to $x$ in streamline coordinates (modified after Foken, 2008). ....	9
Figure 2. The CSAT3 native coordinate system (modified after Campbell Scientific, 2011). ....	10
Figure 3. Gas handling of the IRGA field validation system. The red and green dashed frames show the operational parts during sampling and validation mode, respectively. ....	23
Figure 4. Gas handling of the IRGA field validation system. The green, orange and black dashed frames show the system components during a series of automated leak tests, and the green dashed frame shows the system components during a manual leak test.....	26

Title: NEON Command, Control, and Configuration: Eddy-covariance Turbulent Exchange Subsystem		Date: 0/26/2016
NEON Doc. #: NEON.DOC.000456	Author: D. Durden, S. Metzger, J. Taylor, H. Loescher	Revision: A

Figure 5. Flow chart for water trap command and control. .... 29

## 1 DESCRIPTION

NEON will measure the exchange of momentum, energy and trace gases between the earth’s surface and the atmosphere. To accomplish this, NEON will operate an eddy-covariance turbulent exchange subsystem (EC-TES, a summary of all notation is provided in Sect. 9), which collectively embodies a suite of sensors.

### 1.1 Purpose

This document describes the command, control, and configuration (C<sup>3</sup>) details for operating the EC-TES. It includes a detailed discussion of all necessary requirements for operational control parameters, conditions/constraints, set points, and any necessary error handling. All Level 0 (L0) data products (DPs) generated by the sensors of the EC-TES are identified.

### 1.2 Scope

This C<sup>3</sup> document is embedded in a series of existing and upcoming NEON documents, which collectively describe the acquisition, processing and quality control of data from the EC-TES (AD[01] provides an overview). As such, the scope of this C<sup>3</sup> document is to specify all necessary command, control and configuration that enable acquiring high-quality L0 DPs from EC-TES sensors. In succeeding documents these L0 DPs are further processed into higher-level DPs. It is the current design that the sensors in Table 1 will be used in the EC-TES (AD[02]).

A complete set of the Level 0 data products generated in this document can be found in the appendix.

The Eddy-Covariance Turbulent Exchange Subsystem assembly will consist of the following Data Generating Device’s (DGDs) based on Data Generating Device DGD List and Hierarchies doc (AD [05]):

**Table 1.** Current design of sensors and other infrastructure used in the EC-TES, including DGD Agile part number, DGD Agile description, NEON part number and firmware version.

DGD Agile PN	DGD Agile Description	Sensor	NEON PN	Firmware version
CD00370010	Assembly, CSAT and Electronics Box	Campbell Scientific CSAT3 3-D Sonic Anemometer with V3 embedded code Manufacture part number: 28877	0300010000 (unheated). Heated version is TBD.	3.0
CD00370100	Assembly, Accelerometer and	Xsens attitude and motion reference system.	0346850000	N/A

Title: NEON Command, Control, and Configuration: Eddy-covariance Turbulent Exchange Subsystem		Date: 0/26/2016
NEON Doc. #: NEON.DOC.000456	Author: D. Durden, S. Metzger, J. Taylor, H. Loescher	Revision: A

DGD Agile PN	DGD Agile Description	Sensor	NEON PN	Firmware version
	Cable	Model number: MTi-300-2A5G4		
CD00380100	Assembly, ECTE Sensor Head and Analyzer	LI-COR LI-7200 infrared gas analyzer (includes LI-7200 sensor head and LI-7550 analyzer)	0303030003 (LI-7550 interface box) 0303030004 (LI-7210 Sensor head)	7.3.1
CD06640003	Harness, Grape Digital Out, 5 Solenoid Control	N/A	CD06640003	N/A
CD06640004	Harness, Grape Digital Out, 5 Solenoid Control, 3 Foot	N/A	CD06640004	N/A
CD06450000	Harness, Grape Digital Out, Relay Control, environmental enclosure	N/A	CD06450000	N/A
CA07190000	Assembly, Transducer 0-30 PSI and Cable	Omega Engineering 0-30 psi Absolute Pressure Transducer (PT) 30 psi absolute pressure range, DIN connection style. Model number PX319-030AI.	NEON P/N: 0335460000	N/A
CD07150000	Assembly, 24VDC Pump and Control	GAST Pump, Rotary Vane Vacuum, 24V DC Brushless, 7.2 Amp, 3000 RPM, 0.13 HP, 0.10 KW, 9 Lbs Gast Part No.: 2032-101-G644	0334770000	N/A
CA11460000	Controller, Mass Flow, Whisper Series Flow 0-20 SLPM w/ Display, ID EEPROM, configured with Serial Output Default Frequency: 20Hz	Alicat Controller, Mass Flow, Whisper Series Flow 0-20 SLPM w/ Display. Model: MCRW-20 SLPM-DS-NEON	0341480000	N/A
0341500000	Controller, Mass Flow, 5 SLPM, ID Eeprom	Alicat Controller, Mass Flow, 5 SLPM. Model: MC-5 SLPM-NEON	0341500000	N/A
CA07160000	Assembly, Transducer 0-100 psi and Cable Large	Barksdale Transducer Series 425 with Standard DIN connector, Pressure range 0-	0327230000	N/A

Title: NEON Command, Control, and Configuration: Eddy-covariance Turbulent Exchange Subsystem		Date: 0/26/2016
NEON Doc. #: NEON.DOC.000456	Author: D. Durden, S. Metzger, J. Taylor, H. Loescher	Revision: A

DGD Agile PN	DGD Agile Description	Sensor	NEON PN	Firmware version
		100 psi, 1/4-18 NPT male connect. Model number: 425T5-04		
CA07170000	Assembly, Transducer 0-3000 psi and Cable Large	Barksdale Transducer Series 425 with Standard DIN connector, Pressure range 0-3000 psi, 1/4-18 NPT male connector, Gauge pressure. Model number: 425T5-13	0327240000	N/A
0353710000	Gas Cylinders, High Pressure, Internal Water Volume of 29.5 liters	N/A		

This C<sup>3</sup> document first introduces related documents and conventions (Sect. 2). Followed by the C<sup>3</sup> related to individual sensors of the EC-TES (Sects. 3–8). This document specifies the command, control, and configuration that are needed for operating these sensors and their associated heaters and infrastructure. It does not provide implementation details, except for cases where these stem directly from the sensor conditions as described here. Lastly, all notation used throughout the document is summarized in the appendix (Sect. 0)

## 2 RELATED DOCUMENTS AND ACRONYMS

### 2.1 Applicable documents

AD[01]	NEON.DOC.000573	FIU Plan for Airshed QA/QC Development
AD[02]	NEON.DOC.000291	NEON Configured Sensor List
AD[03]	NEON.DOC.005005	NEON Level 0 Data Products Catalog
AD[04]	NEON.DOC.005004	NEON Level 1–3 Data Products Catalog
AD[05]	NEON.DOC.000807	Eddy-covariance Turbulent Exchange Subsystem Level 0 Prime Data Products ATBD
AD[06]	NEON.DOC.XXXXXX	Eddy-covariance Turbulent Exchange Sensor Maintenance Plan
AD[07]	NEON.DOC.001104	Data Generating Device DGD List and Hierarchies
AD[08]	NEON.DOC.005003	NEON Scientific Data Products Catalog
AD[09]	NEON.DOC.000001	NEON Observatory Design (NOD) Requirements
AD[10]	NEON.DOC.003565	Hut Gas Cylinder Configuration

### 2.2 Reference documents

RD[01]	NEON.DOC.000008	NEON Acronym List
RD[02]	NEON.DOC.000008	NEON Glossary of Abbreviations



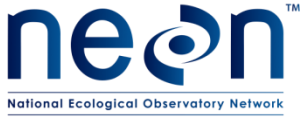

<i>Title:</i> NEON Command, Control, and Configuration: Eddy-covariance Turbulent Exchange Subsystem		<i>Date:</i> 0/26/2016
<i>NEON Doc. #:</i> NEON.DOC.000456	<i>Author:</i> D. Durden, S. Metzger, J. Taylor, H. Loescher	<i>Revision:</i> A

RD[03]	NEON.DOC.011071	FIU Site Specific Sensor Location Matrix
--------	-----------------	------------------------------------------

### 3 ASSEMBLY, CSAT AND ELECTRONICS BOX INTRODUCTION (CD00370010 & CD06450000)

#### 3.1 Introduction

During NEON’s scientific justification process, the Campbell Scientific CSAT3 3-D sonic anemometer (SONIC) and thermometer (Campbell Scientific, 2011) was chosen for fast 3-D wind and temperature measurements at all NEON sites (Table 1).

Here, the command and control procedures and sensor configuration are described to enable the collection of all L0 DPs from the CSAT3 (AD[03]), which are required for the calculation of NEONs L1-L4 DPs (AD[04]) as well as the problem tracking and resolution (PTR).

The CSAT3 shall acquire data at a frequency of 20 Hz. For each datum, the RS–232 output from the CSAT3 consists of five 16 bit words. Each word is related either to a wind component, the sonic temperature, diagnostic values, measurement ranges, or a counter (Table 2). These data are output from the sensor in a binary format. This binary raw data is then collected and interpreted by the Data Acquisition System (DAS), and transmitted to NEON headquarters for processing. The heated version of the CSAT3 is a separate DGD that produces the same data streams as the non-heated plus additional PRT temperature measurements outlined in Table 2. The heater status flag will be sent by DGD CD06450000.

**Table 2.** List of L0 DPs that are acquired from the SONIC and its heater. Please note that the heater flag and its associated L0 DP are communicated and received from DGD CD06450000 (see Sect. 3.3.2).

Data product	Data Format	Units	DP ID
<b>SONIC</b>			
Measured along-axis wind speed ( $u_m$ )	IEEE 754	$m s^{-1}$	NEON.DOM.SITE.DP0.00007.001.01927.HOR.VER.000
Measured cross-axis wind speed ( $v_m$ )	IEEE 754	$m s^{-1}$	NEON.DOM.SITE.DP0.00007.001.01928.HOR.VER.000
Measured vertical-axis wind speed ( $w_m$ )	IEEE 754	$m s^{-1}$	NEON.DOM.SITE.DP0.00007.001.01929.HOR.VER.000
Measured speed of sound in air ( $C_m$ )	IEEE 754	$m s^{-1}$	NEON.DOM.SITE.DP0.00007.001.01308.HOR.VER.000

Title: NEON Command, Control, and Configuration: Eddy-covariance Turbulent Exchange Subsystem		Date: 0/26/2016
NEON Doc. #: NEON.DOC.000456	Author: D. Durden, S. Metzger, J. Taylor, H. Loescher	Revision: A

Data product	Data Format	Units	DP ID
Sample count	IEEE 754	NA	NEON.DOM.SITE.DP0.00007.001.01930.HOR.VER.000
Diagnostic values	32 bit binary (16 leading zeroes followed by 16 bit binary)	NA	NEON.DOM.SITE.DP0.00007.001.01931.HOR.VER.000
<b>Additional stream for heated version</b>			
Temperature transducer zone (top array)	IEEE 754	°C	NEON.DOM.SITE.DP0.00007.001.01932.HOR.VER.000
Temperature transducer zone (bottom array)	IEEE 754	°C	NEON.DOM.SITE.DP0.00007.001.01935.HOR.VER.000
Temperature base block	IEEE 754	°C	NEON.DOM.SITE.DP0.00007.001.01936.HOR.VER.000
Temperature top arm	IEEE 754	°C	NEON.DOM.SITE.DP0.00007.001.01933.HOR.VER.000
Temperature bottom arm	IEEE 754	°C	NEON.DOM.SITE.DP0.00007.001.01934.HOR.VER.000
Heater status (on/off)	1 bit binary	NA	NEON.DOM.SITE.DP0.00008.001.02221.HOR.VER.000

### 3.2 Overview of sensor configuration

The CSAT3 shall be operated with firmware V3 at a data acquisition frequency of 20 Hz. Communication and data transfer with the CSAT3 shall be established using RS–232 serial communication. The RS–232 trigger will enable close synchronization with the H<sub>2</sub>O and CO<sub>2</sub> concentration measurements (Sect. 5). Table 3 summarizes the default sensor configuration settings.

**Table 3.** SONIC default configuration settings.

Parameter	Setting
-----------	---------

Title: NEON Command, Control, and Configuration: Eddy-covariance Turbulent Exchange Subsystem		Date: 0/26/2016
NEON Doc. #: NEON.DOC.000456	Author: D. Durden, S. Metzger, J. Taylor, H. Loescher	Revision: A

Firmware version	V3
Execution parameter	20 Hz, configuration code Ah (60 Hz to 20 Hz oversampling mode)
Serial communication	RS-232
Trigger source (to synchronize measurements)	PC trigger (RS-232 trigger from DAS)
Sampling mode	Three times oversample mode
Captured L0 DPs	Table 2

### 3.3 Command and control

#### 3.3.1 Error handling

Error messages from the CSAT3 are encoded as 32 bit binary ‘Diagnostic values’ L0 DP (NEON.DOM.SITE.DP0.00007.001.01931.HOR.VER.000). Nine individual error messages are decoded in AD[05] and will be published as L1 DPs. These error messages will then be used for automated QA/QC algorithms and PTR assessment. Simplistic error handling should be implemented if any errors are received as a result of lost trigger (“No Data Available”, and “Lost Trigger” errors). The DAS shall attempt to re-establish the trigger.

#### 3.3.2 Sensor switched heating controls specification

The climate at several NEON sites can potentially cause the buildup of hoar frost or rime ice on the body, arms, and transducers of the SONIC. Ice buildup on the anemometer transducers obstructs the signal path, while ice buildup on the anemometer body and arms distorts the wind field. These conditions lead to erroneous measurements by the SONIC. Minimizing the occurrence of these conditions can be achieved by selective sensor heating. There is a current design assumption that the sonic anemometer body and the transducer arms (but not the transducers itself) will have the ability to be heated. Based on this assumption we provide a general command and control structure to determine when the heating tube should be automatically switched on/off. The heating power shall be controlled through an operational feedback loop aiming at 40°C for the arithmetic mean of DP0.00007.001.01932 - DP0.00007.001.01936. The heater shall be turned off immediately if one of DP0.00007.001.01932 - DP0.00007.001.01936 exceeds 60°C, and a trouble ticket shall be sent to the PTR at NEON headquarters (HQ). All set points and below parameters shall be adjustable on a site-specific basis.

Only when there is ice buildup the heater shall be turned on. If the duration of sensor heating exceeds  $t_2=6$  h in a window (trailing average) of  $t_1=24$  h the heating shall be turned off and a trouble ticket shall be sent to PTR at NEON HQ. The status (on/off, L0 DP DP0.00008.001.02221), which is the signal the LC is sending to the grape to control the heaters, shall be continuously recorded. This status cannot guarantee that the heaters are activated, it only provides confirmation that the command and control sequence has been initiated by the LC. In the following two automatic decision processes are

Title: NEON Command, Control, and Configuration: Eddy-covariance Turbulent Exchange Subsystem		Date: 0/26/2016
NEON Doc. #: NEON.DOC.000456	Author: D. Durden, S. Metzger, J. Taylor, H. Loescher	Revision: A

constructed to switch on the heater when ice buildup is detected on (i) the transducers and (ii) the SONIC body and arms.

(i) To detect ice buildup on the transducers, the air temperature at tower top level from the HMP155 ( $T_{air}$ , LO DP DP0.00098.001.01358) and the CSAT3 diagnostic value (LO DP DP0.00007.001.01931), bit 12 ( $b_{12}$ , sonic signal amplitude too low) and bit 14 ( $b_{14}$ , poor signal lock) shall be used. Table 4 summarizes the conditions to switch the heater on/off, based on above DPs and shall be evaluated in the LC on-site.

Table 4. Truth table to control SONIC heater for ice buildup.

Control parameter(s)	Condition	Data acquisition system action	Output to CI
$\alpha, \Psi, \bar{\alpha}, \bar{\Psi}_i, b_{12}, b_{14}$	if( $b_{12}==0$ & $b_{14}==0$ & $\min(\bar{\alpha}(\min(\bar{\Psi}_i) < \Psi \leq \max(\bar{\Psi}_i))) \leq \alpha \leq \max(\bar{\alpha}(\min(\bar{\Psi}_i) < \Psi \leq \max(\bar{\Psi}_i)))$ )	Turn heater off	DP0.00007.001.01927- DP0.00007.001.01931
$T_{air}, b_{12}, b_{14}$	if( $T_{air}+T_{zero} \leq 2^\circ\text{C}$ & ( $b_{12}==1$   $b_{14}==1$ ))	Turn heater on	DP0.00007.001.01927- DP0.00007.001.01931
$T_{air}, \alpha, \Psi, \bar{\alpha}, \bar{\Psi}_i$	if( $T_{air}+T_{zero} \leq 2^\circ\text{C}$ & ( $\alpha < \min(\bar{\alpha}(\min(\bar{\Psi}_i) < \Psi \leq \max(\bar{\Psi}_i)))$   $\alpha > \max(\bar{\alpha}(\min(\bar{\Psi}_i) < \Psi \leq \max(\bar{\Psi}_i)))$ ))	Turn heater on	DP0.00007.001.01927- DP0.00007.001.01931
$t_1, t_2$	if( $t_2 > 0.25 t_1$ )	Turn heater off, send trouble ticket to PTR at HQ	DP0.00007.001.01927- DP0.00007.001.01931

(ii) To detect ice buildup on the SONIC body and arms, a method based on monitoring of the flow angles is used. The specific method that will be used in NEON operations is still in the development stage. Here a method that uses the attack angle  $\alpha$  and the azimuth angle (wind direction)  $\Psi$  is presented as a general guideline, and will be updated once the design of the EC-TES is finalized.

Under conditions close to the freezing point, the heater shall be turned on when measured  $\alpha$  (180 min trailing average, evaluated every 10 min) departs from the range of values  $\bar{\alpha}$  that are predefined for each wind sector  $\bar{\Psi}_i$  (Table 4). These predefined  $\bar{\alpha}, \bar{\Psi}_i$  are based on site-specific long-term averages. Thus they can only be provided once at least a full annual cycle of data is recorded, and are subject to change in time. Until then no predefined values can be supplied, and this part of the heater command

Title: NEON Command, Control, and Configuration: Eddy-covariance Turbulent Exchange Subsystem		Date: 0/26/2016
NEON Doc. #: NEON.DOC.000456	Author: D. Durden, S. Metzger, J. Taylor, H. Loescher	Revision: A

and control shall be disabled. Nevertheless, to facilitate implementation of the necessary algorithms during the construction phase, we provide the required on-site calculations below.

The attack angle  $\alpha$  and the azimuth angle  $\Psi$  define the transformation between the (assumed constant) SONIC coordinate system ( $x_m, y_m, z_m$ ) and the streamline coordinate system ( $x, y, z$ , Figure 1). The orientation of the streamlines is a function of the surrounding terrain, and, to a lesser degree, of the instrument installation. If the instrument installation is significantly modified, e.g. due to ice buildup on the SONIC body or arms, the streamlines are affected. This change is indicated by altered flow angles, in particular by  $\alpha$  due to the low magnitude of the average vertical wind. A threshold for a minimum wind speed may be necessary to prevent false flagging due low wind speeds.

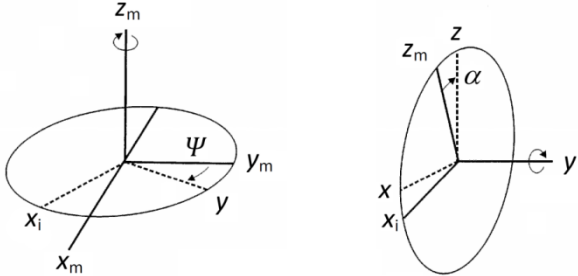

**Figure 1.** The ‘double rotation’, first around the vertical axis  $z_m$  (left), then around the new transverse axis  $y$  (right). The attack angle  $\alpha$  and the azimuth angle  $\Psi$  are shown. The transformation for the x-axis progresses from  $x_m$  over the intermediate step  $x_i$  to  $x$  in streamline coordinates (modified after Foken, 2008).

To calculate the angles  $\alpha, \Psi$ , the wind components in the CSAT3 coordinate system,  $u_m$  (LO DP DP0.00007.001.01927),  $v_m$  (LO DP DP0.00007.001.01928) and  $w_m$  (LO DP DP0.00007.001.01929) must be known. First the azimuth angle  $\Psi$  is calculated from 180 min trailing averages of along-axis  $\overline{u_m}$  and transverse axis  $\overline{v_m}$  wind components. The CSAT3 is defined in a right-hand coordinate system, with the  $x_m$ -axis pointing towards the instrument block (positive  $u_m$  when wind is blowing from the transducer arrays towards the instrument block), the  $y_m$ -axis pointing out of the plane (positive  $v_m$  when wind is blowing out of the plane), and the  $z_m$ -axis pointing upwards (positive  $w_m$  when wind is blowing upwards, Figure 2).

<i>Title:</i> NEON Command, Control, and Configuration: Eddy-covariance Turbulent Exchange Subsystem		<i>Date:</i> 0/26/2016
<i>NEON Doc. #:</i> NEON.DOC.000456	<i>Author:</i> D. Durden, S. Metzger, J. Taylor, H. Loescher	<i>Revision:</i> A

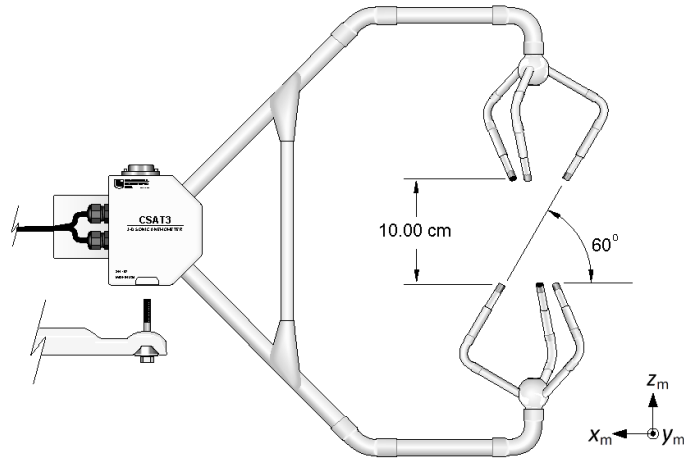

**Figure 2.** The CSAT3 native coordinate system (modified after Campbell Scientific, 2011).

Title: NEON Command, Control, and Configuration: Eddy-covariance Turbulent Exchange Subsystem		Date: 0/26/2016
NEON Doc. #: NEON.DOC.000456	Author: D. Durden, S. Metzger, J. Taylor, H. Loescher	Revision: A

The clockwise azimuth angle in the CSAT3 native coordinate system  $\Psi'''$  [rad] is derived by converting the horizontal wind vector  $(\overline{u}_m, \overline{v}_m)$  into its polar form (e.g., Mori, 1986);

$$\Psi_3 = 2\pi - \left( \tan^{-1} \left( \frac{\overline{v}_m}{\overline{u}_m} \right) + X \right), \quad (1)$$

with the quadrant of the tangent function;

$$X = \begin{cases} 0 & \text{if } \overline{u}_m \geq 0 \ \& \ \overline{v}_m \geq 0, \\ \pi & \text{if } \overline{u}_m \leq 0 \ \& \ \overline{v}_m \geq 0, \end{cases}$$

$$X = \begin{cases} \pi & \text{if } \overline{u}_m \leq 0 \ \& \ \overline{v}_m \leq 0, \\ 2\pi & \text{if } \overline{u}_m \geq 0 \ \& \ \overline{v}_m \leq 0. \end{cases} \quad (2)$$

Now the projection has to be changed from the CSAT3 native coordinate system to the earth coordinate system. This is achieved by adding the clockwise positive azimuth angle offset ( $\Psi_0$  [rad]) between true north (this value will be provided in the site specific as-built) and the sonic  $x_m$ -axis;

$$\Psi_2 = \Psi_3 + \Psi_0, \quad (3)$$

$$\Psi_1 = \begin{cases} \Psi_2 & \text{if } \Psi_2 < 2\pi, \\ \Psi_2 - 2\pi & \text{if } \Psi_2 \geq 2\pi. \end{cases}$$

Finally the resulting angle is converted from radians to decimal degree;

$$\Psi = \Psi_1 \frac{180}{\pi}. \quad (4)$$

Next the magnitude of the average horizontal wind vector in the  $x_m$ - $y_m$  plane of the CSAT3 coordinate system,  $\overline{uv}_m$ , is determined as;

$$\overline{uv}_m = \sqrt{\overline{u}_m^2 + \overline{v}_m^2}. \quad (5)$$

Lastly, the value of the attack angle  $\alpha$  is calculated;

$$\alpha = \tan^{-1} \frac{\overline{w}_m}{\overline{uv}_m}. \quad (6)$$



Title: NEON Command, Control, and Configuration: Eddy-covariance Turbulent Exchange Subsystem		Date: 0/26/2016
NEON Doc. #: NEON.DOC.000456	Author: D. Durden, S. Metzger, J. Taylor, H. Loescher	Revision: A

## 4 ATTITUDE AND MOTION REFERENCE SYSTEM (CD00370100)

### 4.1 Introduction

To correct boom/tower motions and changes in SONIC alignment during maintenance or sensor swaps, the Xsens MTi-300-AHRS attitude and motion reference sensor (Xsens Technologies, 2014) is deployed as part of the EC-TES (Table 1). The MTi-300-AHRS measures accelerations and rotation rates along 3 orthogonal axes, as well as the yaw angle. Using sensor fusion it internally derives pitch and roll angles, and outputs all variables to the data acquisition system (Table 5). Here, we describe the configuration, command and control related to the operation of this sensor.

**Table 5.** List of LO DPs that are acquired from the attitude and motion reference sensor.

Data product	Data Format	Units	DP ID
Measured along-axis inertial acceleration ( $acc_{x,m}$ )	IEEE 754	$m\ s^{-2}$ , positive forward	NEON.DOM.SITE.DP0.00010.001.02200.HOR.VER.000
Measured cross-axis inertial acceleration ( $acc_{y,m}$ )	IEEE 754	$m\ s^{-2}$ , positive left	NEON.DOM.SITE.DP0.00010.001.02201.HOR.VER.000
Measured vertical-axis inertial acceleration ( $acc_{z,m}$ )	IEEE 754	$m\ s^{-2}$ , positive up	NEON.DOM.SITE.DP0.00010.001.02202.HOR.VER.000
Along-axis free acceleration	IEEE 754	$m\ s^{-2}$ , positive forward	NEON.DOM.SITE.DP0.00010.001.02203.HOR.VER.000
Cross-axis free acceleration	IEEE 754	$m\ s^{-2}$ , positive left	NEON.DOM.SITE.DP0.00010.001.02204.HOR.VER.000
Vertical-axis free acceleration	IEEE 754	$m\ s^{-2}$ , positive up	NEON.DOM.SITE.DP0.00010.001.02205.HOR.VER.000
Pitch rate	IEEE 754	$rad\ s^{-1}$ , positive clockwise	NEON.DOM.SITE.DP0.00010.001.02206.HOR.VER.000
Roll rate	IEEE 754	$rad\ s^{-1}$ , positive	NEON.DOM.SITE.DP0.00010.001.02207.HOR.VER.000

Title: NEON Command, Control, and Configuration: Eddy-covariance Turbulent Exchange Subsystem		Date: 0/26/2016
NEON Doc. #: NEON.DOC.000456	Author: D. Durden, S. Metzger, J. Taylor, H. Loescher	Revision: A

		clockwise	
Yaw rate	IEEE 754	rad s <sup>-1</sup> , positive clockwise	NEON.DOM.SITE.DP0.00010.001.02208.HOR.VER.000
Measured pitch angle ( $\theta_m$ )	IEEE 754	Decimal degree	NEON.DOM.SITE.DP0.00010.001.02209.HOR.VER.000
Measured roll angle ( $\phi_m$ )	IEEE 754	Decimal degree	NEON.DOM.SITE.DP0.00010.001.02210.HOR.VER.000
Yaw angle	IEEE 754	Decimal degree against magnetic north	NEON.DOM.SITE.DP0.00010.001.02211.HOR.VER.000
Index	IEEE 754	NA	NEON.DOM.SITE.DP0.00010.001.01930.HOR.VER.000
Status word	32 bit binary	NA	NEON.DOM.SITE.DP0.00010.001.01930.HOR.VER.000

## 4.2 Overview of sensor configuration

To ensure similar time-frequency resolution with wind and concentration measurements, a data acquisition frequency of 40 Hz shall be chosen. However, during validation and verification testing the MTi-300-AHRS may be operated with a data acquisition frequency of 400 Hz (Sect. 9.1). The default configuration settings for the MTi-300-AHRS are summarized in Table 6.

Title: NEON Command, Control, and Configuration: Eddy-covariance Turbulent Exchange Subsystem		Date: 0/26/2016
NEON Doc. #: NEON.DOC.000456	Author: D. Durden, S. Metzger, J. Taylor, H. Loescher	Revision: A

**Table 6.** Default configuration settings for the MTi-300-AHRS attitude and motion reference sensor.

Parameter	Setting
Sensor/Body coordinate system	forward-left-up (sensor-default)
Sensor/Reference coordinate system	east-north-up (ENU, sensor default)
Sensor/Misalignment	no misalignment
Sensor/GPS lever arm	no displacement
Heading reference	-
Motion profile	low mag_dep
Data Output/Status	status word
Data Output/Inertial Data	rate of turn, acceleration, free acceleration
Data Output/Orientation	Euler Angles
output frequency	40 Hz
output configuration	trigger
protocol	MTI low-level
serial communication	RS-232
baudrate	115200
data bits	8
parity	none
stop bits	1
flow control	disabled
Captured L0 DPs	Table 5

### 4.3 Command and control

There is no command and control for the attitude and motion reference system.

## 5 H<sub>2</sub>O AND CO<sub>2</sub> CONCENTRATION MEASUREMENT (CD00380100, CD06640003, CD06640004, CD06450000, & CA07190000)

During NEON’s scientific justification process, the LI-COR LI-7200 infrared gas analyzer (IRGA, LI-COR Inc., 2013) was chosen for the fast (turbulent-scale) measurement of H<sub>2</sub>O and CO<sub>2</sub> concentrations at all NEON sites (Table 1). If additional fast-response gas analyzers will be added in the future, this document will be revised accordingly. All infrastructure required to perform sampling and validation is outlined in the subsequent sections.

### 5.1 Introduction

The fast H<sub>2</sub>O and CO<sub>2</sub> concentration measurement are collected through the combination of an optical sample cell in the LI-7200 sensor head, and a separate electronics box that performs the digital signal processing (LI-7550 analyzer). Here, the command and control procedures and the sensor configuration are described that enable the collection of all L0 DPs from the LI-7200 (AD[03]) which are required for

Title: NEON Command, Control, and Configuration: Eddy-covariance Turbulent Exchange Subsystem		Date: 0/26/2016
NEON Doc. #: NEON.DOC.000456	Author: D. Durden, S. Metzger, J. Taylor, H. Loescher	Revision: A

the calculation of NEONs higher level DPs (AD[04]) as well as the PTR of H<sub>2</sub>O dry mole fraction and CO<sub>2</sub> dry mole fraction.

The LI-7200 shall sample data at a frequency of 20 Hz. Table 7 summarizes the data that are output by the LI-7200 and shall be acquired as L0 DPs (AD[03]). Measurements of thermodynamic properties, H<sub>2</sub>O and CO<sub>2</sub> are output as floating point values (IEEE 754 format), whereas the LI-7200 diagnostic value is output as 16 bit binary.

**Table 7.** List of L0 DPs that are produced by the LI-7200.

DP	Data Format	Units	DP ID
<b>Thermodynamic</b>			
Cell temperature in (at sensor head inlet)	IEEE 754	°C	NEON.DOM.SITE.D P0.00016.001.0217 8.HOR.VER.000
Cell temperature out (at sensor head outlet)	IEEE 754	°C	NEON.DOM.SITE.D P0.00016.001.0217 9.HOR.VER.000
Block temperature	IEEE 754	°C	NEON.DOM.SITE.D P0.00016.001.0218 0.HOR.VER.000
Ambient pressure (LI-7550 box pressure)	IEEE 754	kPa	NEON.DOM.SITE.D P0.00016.001.0218 1.HOR.VER.000
Head pressure (differential pressure head-box)	IEEE 754	kPa	NEON.DOM.SITE.D P0.00016.001.0217 8.HOR.VER.000
<b>H<sub>2</sub>O</b>			
H <sub>2</sub> O sample power	IEEE 754	W	NEON.DOM.SITE.DP 0.00016.001.02182. HOR.VER.000
H <sub>2</sub> O reference power	IEEE 754	W	NEON.DOM.SITE.DP 0.00016.001.02183. HOR.VER.000
H <sub>2</sub> O raw absorptance	IEEE 754	Dimensionless ratio	NEON.DOM.SITE.DP 0.00016.001.02184. HOR.VER.000
H <sub>2</sub> O molar density	IEEE 754	mmol m <sup>-3</sup>	NEON.DOM.SITE.DP 0.00016.001.02185. HOR.VER.000
H <sub>2</sub> O mixing ratio (dry mole fraction)	IEEE 754	mmol mol <sup>-1</sup>	NEON.DOM.SITE.DP 0.00016.001.02186. HOR.VER.000

Title: NEON Command, Control, and Configuration: Eddy-covariance Turbulent Exchange Subsystem		Date: 0/26/2016
NEON Doc. #: NEON.DOC.000456	Author: D. Durden, S. Metzger, J. Taylor, H. Loescher	Revision: A

CO <sub>2</sub>			
CO <sub>2</sub> sample power	IEEE 754	W	NEON.DOM.SITE.DP 0.00016.001.02186. HOR.VER.000
CO <sub>2</sub> reference power	IEEE 754	W	NEON.DOM.SITE.DP 0.00016.001.02187. HOR.VER.000
CO <sub>2</sub> raw absorptance	IEEE 754	Dimensionless ratio	NEON.DOM.SITE.DP 0.00016.001.02188. HOR.VER.000
CO <sub>2</sub> molar density	IEEE 754	mmol m <sup>-3</sup>	NEON.DOM.SITE.DP 0.00016.001.02189. HOR.VER.000
CO <sub>2</sub> mixing ratio (dry mole fraction)	IEEE 754	μmol mol <sup>-1</sup>	NEON.DOM.SITE.DP 0.00016.001.02190. HOR.VER.000
Diagnostic values			
Sequence number	IEEE 754	NA	NEON.DOM.SITE.DP 0.00016.001.01930. HOR.VER.000
LI-7200 diagnostic value	16 bit binary	NA	NEON.DOM.SITE.DP 0.00016.001.01931. HOR.VER.000
LI-7200 diagnostic value 2 (sync clocks)	1 bit binary	NA	NEON.DOM.SITE.DP 0.00016.001.02192. HOR.VER.000
LI-7200 cooler voltage	IEEE 754	V	NEON.DOM.SITE.DP 0.00016.001.02193. HOR.VER.000
CO <sub>2</sub> signal strength	IEEE 754	%	NEON.DOM.SITE.DP 0.00016.001.02194. HOR.VER.000
H <sub>2</sub> O signal strength	IEEE 754	%	NEON.DOM.SITE.DP 0.00016.001.02195. HOR.VER.000

## 5.2 Overview of sensor configuration

The LI-7200 shall communicate with the location controller via Ethernet at a data acquisition frequency of 20 Hz. Ethernet PTP version 1 shall be used to synchronize the measurements to the location controller to within 10 ms accuracy and 1 ms precision (LI-COR Inc., 2013). Table 8 summarizes the default sensor configuration settings, which must also be captured for each sensor as metadata. If there

Title: NEON Command, Control, and Configuration: Eddy-covariance Turbulent Exchange Subsystem		Date: 0/26/2016
NEON Doc. #: NEON.DOC.000456	Author: D. Durden, S. Metzger, J. Taylor, H. Loescher	Revision: A

is a power failure (and maybe in other unforeseen circumstances), the LI-7200 shall be remotely reset to the default sensor configuration settings, either manually or automatically.

**Table 8.** Infrared gas analyzer default configuration settings. Because these are sensor settings, tolerances are not available.

Parameter	Setting
Data collection rate	20 Hz
Bandwidth setting	10 Hz
Firmware version	7.3.1*
SONIC input	Not used
Data communication	Ethernet
Captured LO DPs	Table 7
Update rate	20 Hz
Data labels	Off
Diagnostic text records	Off
Length of data files	3600 s
Clock sync (PTP)	Automatic
Chopper housing temperature	30°C
Delay step increment	12 steps == 210 ms
Temperature reference	Onboard sensor
Pressure reference	Onboard sensor

\*The version of LI-COR software on laptops used for maintenance shall be kept compatible with the LI-7200 firmware.

### 5.3 Command and control

The current design requires the EC-TES to be operated in three modes, (i) sampling of ambient air, (ii) field validation and (iii) leak testing. In the following we describe the command and control of these operation modes, as well as the continuous heating of the intake tube, the switched heating of the rain cap, validation tube heating, SONIC heating, and water trap operation. For these purposes solenoid valves, a vacuum pump (Sect. 6), flow controllers (Sect. 7), and gas pressure sensors (Sect. 8) are used. Their default settings, command and control is provided in respective sections. Regardless of the mode of operation, all DPs in Table 9 shall be recorded continuously, at 0.2 Hz and 1 Hz, respectively.

**Table 9.** List of LO DPs related to LI-7200 operation modes and switched rain cap heating.

DP	Data format	Units	DP ID
<b>General</b>			
Vacuum pump voltage	IEEE 754	volt	NEON.DOM.SITE .DP0.00116.001. 02351.HOR.VER.

Title: NEON Command, Control, and Configuration: Eddy-covariance Turbulent Exchange Subsystem		Date: 0/26/2016
NEON Doc. #: NEON.DOC.000456	Author: D. Durden, S. Metzger, J. Taylor, H. Loescher	Revision: A

			000
Sampling / validation solenoid status (on/off)	1 bit binary	NA	NEON.DOM.SITE .DP0.00008.001. 02199.HOR.VER. 000
<b>Sampling</b>			
Sampling mass flow rate set point (Alicat MCRW, Sect. 0)	IEEE 754	LPM	NEON.DOM.SITE .DP0.00012.001. 01952.HOR.VER. 000
Sampling mass flow rate (Alicat MCRW, Sect. 0)	IEEE 754	LPM	NEON.DOM.SITE .DP0.00012.001. 01951.HOR.VER. 000
Sampling volumetric flow rate (Alicat MCRW, Sect. 0)	IEEE 754	LPM	NEON.DOM.SITE .DP0.00012.001. 01950.HOR.VER. 000
Sampling gas pressure (Absolute) (Alicat MCRW, Sect. 0)	IEEE 754	kilopascal	NEON.DOM.SITE .DP0.00012.001. 01948.HOR.VER. 000
Sampling gas temperature (Alicat MCRW, Sect. 0)	IEEE 754	°C	NEON.DOM.SITE .DP0.00012.001. 01949.HOR.VER. 000
<b>Field validation</b>			
Validation mass flow rate set point (Alicat MCRW, Sect. 0)	IEEE 754	LPM	NEON.DOM.SITE .DP0.00015.001. 01952.HOR.VER. 000
Validation mass flow rate (Alicat MCRW, Sect. 0)	IEEE 754	LPM	NEON.DOM.SITE .DP0.00015.001. 01951.HOR.VER. 000
Validation volumetric flow rate (Alicat MCRW, Sect. 0)	IEEE 754	LPM	NEON.DOM.SITE .DP0.00015.001. 01950.HOR.VER. 000
Validation gas pressure (Absolute) (Alicat MCRW, Sect. 0)	IEEE 754	kPa	NEON.DOM.SITE .DP0.00015.001. 01948.HOR.VER. 000
Validation gas temperature (Alicat MCRW, Sect. 0)	IEEE 754	°C	NEON.DOM.SITE .DP0.00015.001.

Title: NEON Command, Control, and Configuration: Eddy-covariance Turbulent Exchange Subsystem		Date: 0/26/2016
NEON Doc. #: NEON.DOC.000456	Author: D. Durden, S. Metzger, J. Taylor, H. Loescher	Revision: A

			01949.HOR.VER.000
Validation gas 1–5 hut solenoid status (on / off)	1 bit binary	NA	NEON.DOM.SITE.DP0.00011.001.02212.HOR.VER.000 - NEON.DOM.SITE.DP0.00011.001.02216.HOR.VER.000
Validation gas 1–5 NEMA solenoid status enclosure (on / off)	1 bit binary	NA	NEON.DOM.SITE.DP0.00009.001.02212.HOR.VER.000 - NEON.DOM.SITE.DP0.00009.001.02216.HOR.VER.000
Validation gas 1–5 cylinder pressure (gage) (Omega PX-329-3KG5V, Sect. 8)	IEEE 754	kPa	NEON.DOM.SITE.DP0.00034.001.02196.HOR.VER.000 (separated by HOR 001-005)
Validation gas 1–5 delivery pressure (gage) (Omega PX-329-100G5V, Sect. 8)	IEEE 754	kPa	NEON.DOM.SITE.DP0.00035.001.02196.HOR.VER.000 (separated by HOR 001-005)
Validation gas path heater status (on/off)	1 bit binary	NA	NEON.DOM.SITE.DP0.00008.001.02224.HOR.VER.000
<b>DP</b>	<b>Data format</b>	<b>Units</b>	<b>DP ID</b>
<b>Heating</b>			
Continuous intake tube heater status (on/off)	1 bit binary	NA	NEON.DOM.SITE.DP0.00008.001.02222.HOR.VER.000
Switched rain cap heater status (on/off)	1 bit binary	NA	NEON.DOM.SITE.DP0.00008.001.02223.HOR.VER.000



Water trap			
Pressure (gage) water trap ( $p_{\text{trap}}$ )	IEEE 754	kPa	NEON.DOM.SITE .DPO.00036.001. 02196.HOR.VER. 000
Water trap inlet valve status (on/off)	1 bit binary	NA	NEON.DOM.SITE .DPO.00008.001. 02197.HOR.VER. 000
Water trap vent valve status (on/off)	1 bit binary	NA	NEON.DOM.SITE .DPO.00008.001. 02198.HOR.VER. 000

Table 10 provides an overview of settings and corresponding status during the three principal modes of LI-7200 operation.

**Table 10.** List of settings and corresponding status during the three principal modes of LI-7200 operation.

DP	DP ID	Sampling mode	Validation mode					Leak test mode			
			Gas 1	Gas 2	Gas 3	Gas 4	Gas 5	Test 1	Test 2	Test 3	Test 4
Sampling / validation solenoid status (on/off)	NEON.DOM.SITE.DPO.00008.001.02199.HOR.VER.000	0	1	1	1	1	1	0	0	1	0
Validation gas 1 status hut (on / off)	NEON.DOM.SITE.DPO.00011.001.02212.HOR.VER.000	0	1	0	0	0	0	0	0	0	0
Validation gas 2 status hut (on / off)	NEON.DOM.SITE.DPO.00011.001.02213.HOR.VER.000	0	0	1	0	0	0	0	0	0	0
Validation gas 3 status hut (on / off)	NEON.DOM.SITE.DPO.00011.001.02214.HOR.VER.000	0	0	0	1	0	0	0	0	0	0
Validation gas 4 status hut (on / off)	NEON.DOM.SITE.DPO.00011.001.02215.HOR.VER.000	0	0	0	0	1	0	0	0	0	0

Title: NEON Command, Control, and Configuration: Eddy-covariance Turbulent Exchange Subsystem		Date: 0/26/2016
NEON Doc. #: NEON.DOC.000456	Author: D. Durden, S. Metzger, J. Taylor, H. Loescher	Revision: A

Validation gas 5 status hut (on / off)	NEON.DOM.SIT E.DP0.00011.00 1.02216.HOR.V ER.000	0	0	0	0	0	1	0	0	0	0
Validation gas 1 status NEMA (on / off)	NEON.DOM.SIT E.DP0.00009.00 1.02212.HOR.V ER.000	0	1	0	0	0	0	0	0	0	0
Validation gas 2 status NEMA (on / off)	NEON.DOM.SIT E.DP0.00009.00 1.02213.HOR.V ER.000	0	0	1	0	0	0	0	0	0	0
Validation gas 3 status NEMA (on / off)	NEON.DOM.SIT E.DP0.00009.00 1.02214.HOR.V ER.000	0	0	0	1	0	0	0	0	0	0
Validation gas 4 status NEMA (on / off)	NEON.DOM.SIT E.DP0.00009.00 1.02215.HOR.V ER.000	0	0	0	0	1	0	0	0	0	0
Validation gas 5 status NEMA (on / off)	NEON.DOM.SIT E.DP0.00009.00 1.02216.HOR.V ER.000	0	0	0	0	0	1	0	0	0	0
Validation gas path heater status (on/off)	NEON.DOM.SIT E.DP0.00008.00 1.02224.HOR.V ER.000	0	0/1	0/1	0/1	0/1	0/1	0	0	0	0
Continuous intake tube heater status (on/off)	NEON.DOM.SIT E.DP0.00008.00 1.02222.HOR.V ER.000	0/1	0/1	0/1	0/1	0/1	0/1	0/1	0/1	0/1	0/1
Switched rain cap heater status (on/off)	NEON.DOM.SIT E.DP0.00008.00 1.02223.HOR.V ER.000	0/1	0	0	0	0	0	0	0	0	0

Title: NEON Command, Control, and Configuration: Eddy-covariance Turbulent Exchange Subsystem		Date: 0/26/2016
NEON Doc. #: NEON.DOC.000456	Author: D. Durden, S. Metzger, J. Taylor, H. Loescher	Revision: A

### 5.3.1 Error handling

Error messages from the LI-7200 are encoded as 16 bit binary diagnostic value L0 DP. Ten individual error messages will be subsequently decoded in the respective ATBD (AD[05]), and will be provided as a L1 DPs. These error messages will then be used for PTR as well as for automated QA/QC algorithms. No additional automatic/programmed queries are needed to determine any other error in function.

### 5.3.2 Sampling mode controls specification

The IRGA field validation system consists of an array of gas supplies, valves and sensors, which integrates all three modes of operation into one single design (Figure 3). During sampling the vacuum pump pulls air from the IRGA intake, which passes through the IRGA optical cell and subsequently by the water trap (Figure 3, red dashed frame). The settings and corresponding status of individual infrastructure parts are summarized in Table 10 and Table 11.

**Table 11.** Configuration of the sampling mode.

Parameter	Default Setting
Vacuum pump status	On
Sampling mass flow controller set point	12 SLPM

### 5.3.3 Field validation controls specification

Field validation is performed to periodically monitor and assess IRGA absorptance zero drift (H<sub>2</sub>O and CO<sub>2</sub>), as well as the IRGA zero coefficient (H<sub>2</sub>O and CO<sub>2</sub>) and span coefficient (CO<sub>2</sub>). To perform the field validation, gas cylinders containing zero-air gas as well as four known CO<sub>2</sub> concentrations are used. Related L0 DPs in Table 9 shall be recorded continuously. The field validation shall be performed automatically at predefined time intervals. In addition it shall be possible to trigger a validation cycle manually during site routine maintenance. During field validation the validation gas supply J3 shall be connected to the IRGA optical cell and vented through the IRGA intake (Figure 3, green frame). We anticipate the total volume in all of the gas handling in the field validation system to be  $\approx 1.5 \cdot 10^{-4} \text{ m}^3$  or 0.15 L (7.5 m of 0.0048 m ID tubing, optical cell, valves and manifolds). This volume shall be purged until the rate of change of absorptance of H<sub>2</sub>O and CO<sub>2</sub> (L0 DP NEON.DOM.SITE.DP0.00016.001.02184.HOR.VER.000, NEON.DOM.SITE.DP0.00016.001.02189.HOR.VER.000) falls below  $5 \cdot 10^{-5} \text{ s}^{-1}$  for a trailing 2 min average. We anticipate approximate equilibrium after  $\approx 35$  purges of the system volume, corresponding to  $\approx 3.5$  min flushing at a flow rate of  $\approx 1.5 \text{ L min}^{-1}$ . After equilibrium is reached, the supply of validation gas shall continue for another 1.5 min, during which period the data for the actual field validation is collected. The validation cycle for each validation gas lasts 5 min, including the times for purging and acquisition of valid field validation data. The cycle shall be carried out, in sequence, for zero gas, three

validation gases from lowest to highest concentration, and zero gas. The entire validation cycle lasts 25 min, and every 164.5 h a fifth gas standard (high-accuracy long time standard) shall be added to the end of the validation cycle, extending the overall duration to 30 min. The field validation is performed on a fixed-date basis, every 23.5 h with respect to Coordinated Universal Time, regardless of the system being subjected to downtime between field validations. A field validation starts either at the beginning of the hour (00:00.00) or the beginning of the half-hour (30:00.00). The combination of valve activations will be used to determine the leak test or validation cycle that is being performed in the L0 prime ATBD ([AD 05]).

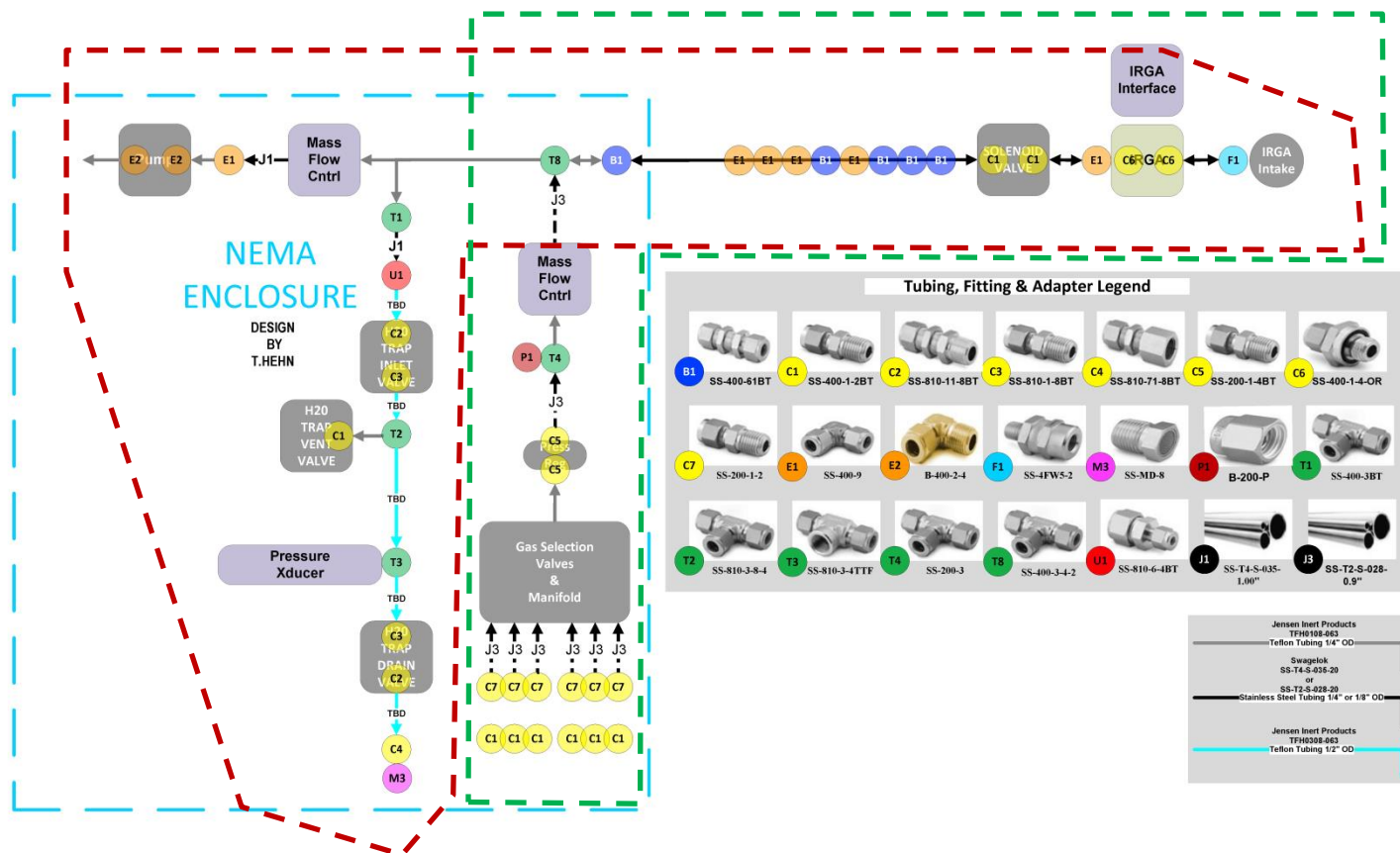

**Figure 3.** Gas handling of the IRGA field validation system. The red and green dashed frames show the operational parts during sampling and validation mode, respectively.

The sampling mode (Sect. 5.3.1) shall resume immediately after the last validation standard is measured. It is the current assumption that it will take substantially less than one minute for the gas plumbing to reach sampling steady-state, thus no more than 30 min of continuous data coverage is lost. The configuration for this validation cycle is summarized in Table 12 and the settings and corresponding status of individual infrastructure parts is summarized in Table 10.

Title: NEON Command, Control, and Configuration: Eddy-covariance Turbulent Exchange Subsystem		Date: 0/26/2016
NEON Doc. #: NEON.DOC.000456	Author: D. Durden, S. Metzger, J. Taylor, H. Loescher	Revision: A

**Table 12.** Configuration of the field validation.

Parameter	Default Setting
Validation recurrence	Every 23.5 h (routine validation) and 164.5 h (high-accuracy long term standard) with respect to Coordinated Universal Time, regardless of the system being subjected to downtime between field validations
Overall duration	25 min (routine validation), 30 min (including high-accuracy long term standard)
Vacuum pump status	Off
Validation gas standards	Zero gas and three gas standards for routine validation, one high-accuracy long term standard
Duration for each validation gas standard	5 min
Validation mass flow rate set point	1.5 LPM
Validation gas path heater	Control gas temperature such that IRGA head inlet temperature (LO DP NEON.DOM.SITE.DPO.00016.001.02178.HOR.VER.000) during field validation differs <3°C from the IRGA head outlet temperature (LO DP NEON.DOM.SITE.DPO.00016.001.02179.HOR.VER.000) from the preceding sampling mode. Both temperatures used for control are derived using a 60 s trailing average.

### 5.3.4 Leak test controls specification

Leak testing of the IRGA gas plumbing system can be performed through applying a vacuum to individual system components. Two principal modes of leak tests are available, (i) an automated leak test and (ii) a manual leak test.

During the automated leak test, air is plumbed identical to the sampling mode (Sect. 5.3.1), i.e. the vacuum pump pulls air from the IRGA intake, which passes through the IRGA optical cell and subsequently by the water trap. In this configuration, several solenoids are switched in a predefined sequence to isolate individual parts of the gas plumbing:

1. Vacuum pump to solenoid (Figure 4, red dashed frame);
2. Vacuum pump to solenoid, including water trap (Figure 4, orange dashed frame);
3. Vacuum pump to solenoid, including validation gas selection manifold (Figure 4, black dashed frame);

The settings and corresponding status of individual infrastructure parts is summarized in Table 10. Each time that a routine field validation is performed (i.e., every time that no high-accuracy long time

Title: NEON Command, Control, and Configuration: Eddy-covariance Turbulent Exchange Subsystem		Date: 0/26/2016
NEON Doc. #: NEON.DOC.000456	Author: D. Durden, S. Metzger, J. Taylor, H. Loescher	Revision: A

standard is used, Sect. 0), the automated leak test sequence 1.–3. shall be added to the end of the validation cycle. The automated leak test sequence 1.–3. shall take no longer than 5 min, extending the overall duration of field validation and automated leak test to 30 min. The sampling mode (Sect. 5.3.1) shall resume immediately after the automated leak test sequence is completed.

Every time after part of the IRGA gas plumbing system was disassembled (e.g., intake filter change), in addition to the automated leak test sequence 1.–3., a manual leak test is performed:

4. Vacuum pump to rain cap (Figure 4, green dashed frame).

The settings and corresponding status of individual infrastructure parts are summarized in Table 10 and Table 13.

**Table 13.** Configuration of the leak testing.

Parameter	Default Setting
Recurrence of automated leak test sequence (Test 1–3)	Every 23.5 h immediately following routine validation sequence, but not at 164.5 h (validation sequence including high-accuracy long time standard validation)
Recurrence of manual leak test sequence (Test 1–4)	Every time after part of the IRGA gas plumbing system was disassembled (e.g., intake filter change)
Overall duration	5 min (automated leak test), user-dependent (manual leak test)
Vacuum pump status	On
Sampling mass flow rate set point	12 SLPM
Test 1	Vacuum pump to solenoid (Figure 4, red dashed frame, Table 10)
Test 2	Vacuum pump to solenoid, including water trap (Figure 4, orange dashed frame, Table 10)
Test 3	Vacuum pump to solenoid, including validation gas selection manifold (Figure 4, black dashed frame, Table 10)
Test 4	Vacuum pump to rain cap (Figure 4, green dashed frame, Table 10)

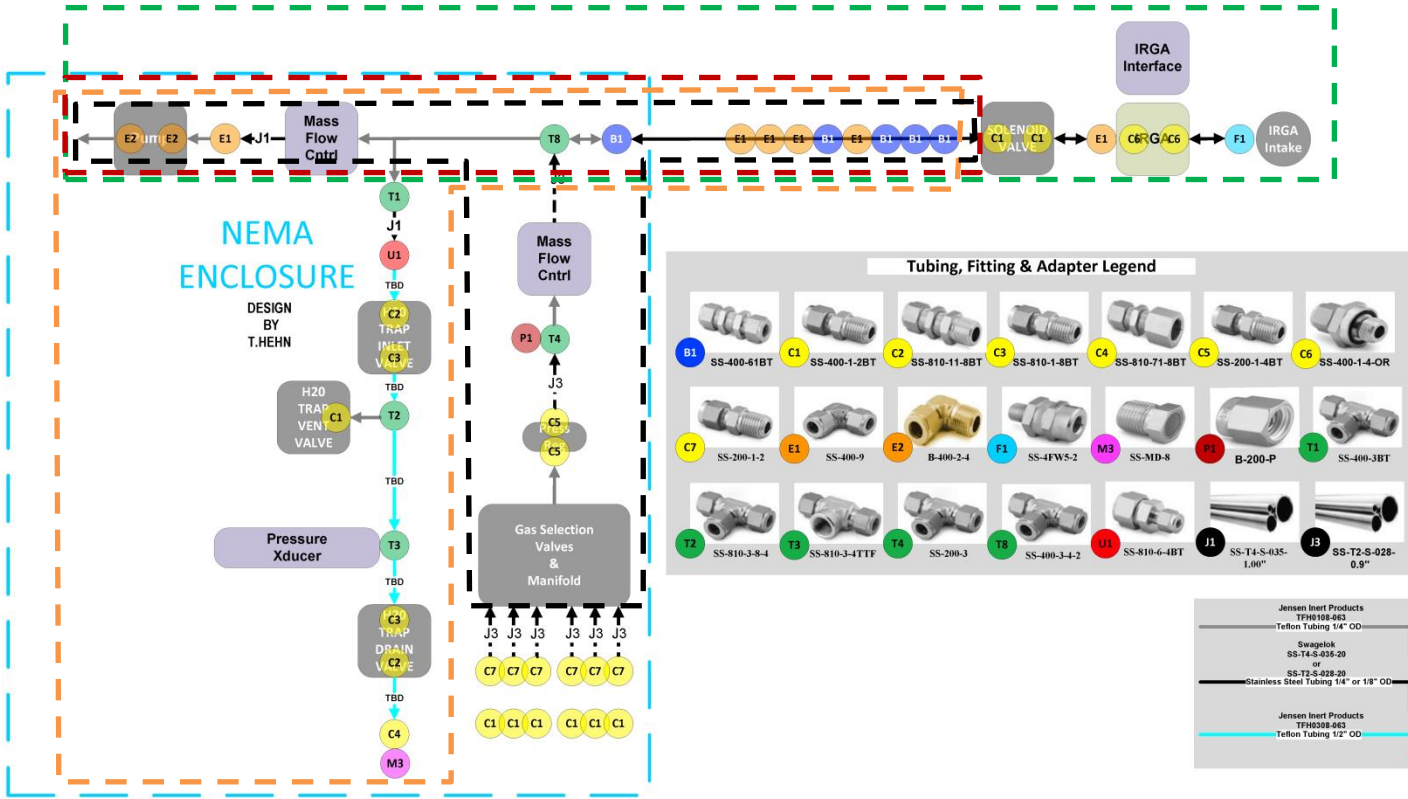

**Figure 4.** Gas handling of the IRGA field validation system. The green, orange and black dashed frames show the system components during a series of automated leak tests, and the green dashed frame shows the system components during a manual leak test.

**5.3.5 Intake tube continuous heating controls specification**

The intake tube consists of a 70 cm long stainless steel tube with 4.8 mm ID and a Swagelok FW 2 μm pleated mesh filter covering the atmosphere-side opening. The entire length of the intake tube is insulated (15 mm) and heated (Watlow #010300C1). Table 14 summarizes the configuration of the continuous intake tube heating.

**Table 14.** Configuration of the continuous intake tube heating.

Parameter	Default Setting
Recurrence	Continuous
Heating power	4 W

Title: NEON Command, Control, and Configuration: Eddy-covariance Turbulent Exchange Subsystem		Date: 0/26/2016
NEON Doc. #: NEON.DOC.000456	Author: D. Durden, S. Metzger, J. Taylor, H. Loescher	Revision: A

### 5.3.6 Rain cap switched heating controls specification

IRGA rain cap heating is enabled as function of differential pressure head-box ( $dp_{IRGA}$ , LO DP NEON.DOM.SITE.DP0.00016.001.02181.HOR.VER.000  $\cdot 10^3$ ), dew point temperature  $T_{H2O}$  (LO DP NEON.DOM.SITE.DP0.00098.001.01358.HOR.VER.000  $- T_{zero}$ ), and ambient temperature ( $T_{air}$ , LO DP NEON.DOM.SITE.DP0.00098.001.01309.HOR.VER.000).

These variables are evaluated using a continuous trailing 10 min average. If the heating duration exceeds  $t_2=6$  h in a window (trailing average) of  $t_1=24$  h the heating and the vacuum pump shall be turned off, and a trouble ticket shall be sent to PTR at NEON HQ. The heating controls are summarized in Table 15.

**Table 15.** Truth table to control the switched rain cap heater.

Control parameter(s)	Condition	Data acquisition system action	Output to CI
$dp_{IRGA}, T_{air}, T_{H2O}$	if( $dp_{IRGA} > 2000$ Pa & $T_{air} < -T_{zero} + 3 \pm 1$ K & $T_{air} < T_{H2O} + 3 \pm 1$ K)	Turn heater on	Summarized in Table 9 and Table 10
$dp_{IRGA}, T_{air}, T_{H2O}$	if( $dp_{IRGA} < 2000$ Pa   $T_{air} > -T_{zero} + 3 \pm 1$ K   $T_{air} > T_{H2O} + 3 \pm 1$ K)	Turn heater off	Summarized in Table 9 and Table 10
$t_1, t_2$	if( $t_2 > 0.25 t_1$ )	Turn heater and vacuum pump off, send trouble ticket to PTR at HQ	Summarized in Table 9 and Table 10

### 5.3.7 Water trap controls specification

The command and control for the water trap is outlined in Figure 5 and summarized in Table 16. The trap's inlet valve is normally open, the vent and drain valves are normally closed. When the pressure difference ( $p_{diff}$ ) between the absolute pressures measured by the trap pressure sensor (DGD CA07190000) and the sampling mass flow controller (DGD CA11460000, see Sect. 7) ( $p_{trap}$  and  $p_{mfc}$ ) indicates that the trap is nearly full ( $p_{diff,max}=3$  kPa), (i) the inlet valve is closed, and (ii) the vent and drain valves are opened. If the pressure does not decrease with a rate  $\Delta p_{trap}/\Delta t=60$  Pa  $s^{-1}$  or faster, or if the drain time  $t_{drain}$  exceeds  $t_{drain,max}=600$  s, the pump is shut down and a trouble ticket is issued. Once  $p_{diff}$



falls below  $p_{diff,min}=0.1$  kPa, (i) the vent and drain valves are closed and (ii) the inlet is opened. Above parameter values are initial values, and will be updated in the CI data store.

Table 16. Truth table to control the water trap.

Control parameter(s)	Condition	Data acquisition system action	Output to CI
$p_{diff}, p_{max}$	$p_{diff} > p_{diff,max}$	Close inlet valve Open vent valve Open drain valve	Summarized in Table 9
$\Delta p_{trap}/\Delta t, t_{drain}, t_{drain,max}$	$\Delta p_{trap}/\Delta t < 60$ $Pa s^{-1} \mid t_{drain} > t_{drain,max}$	Shut down pump Issue trouble ticket	Summarized in Table 9
$p_{diff}, p_{diff,min}$	$p_{diff} < p_{diff,min}$	Close vent valve Close drain valve Open inlet valve	Summarized in Table 9

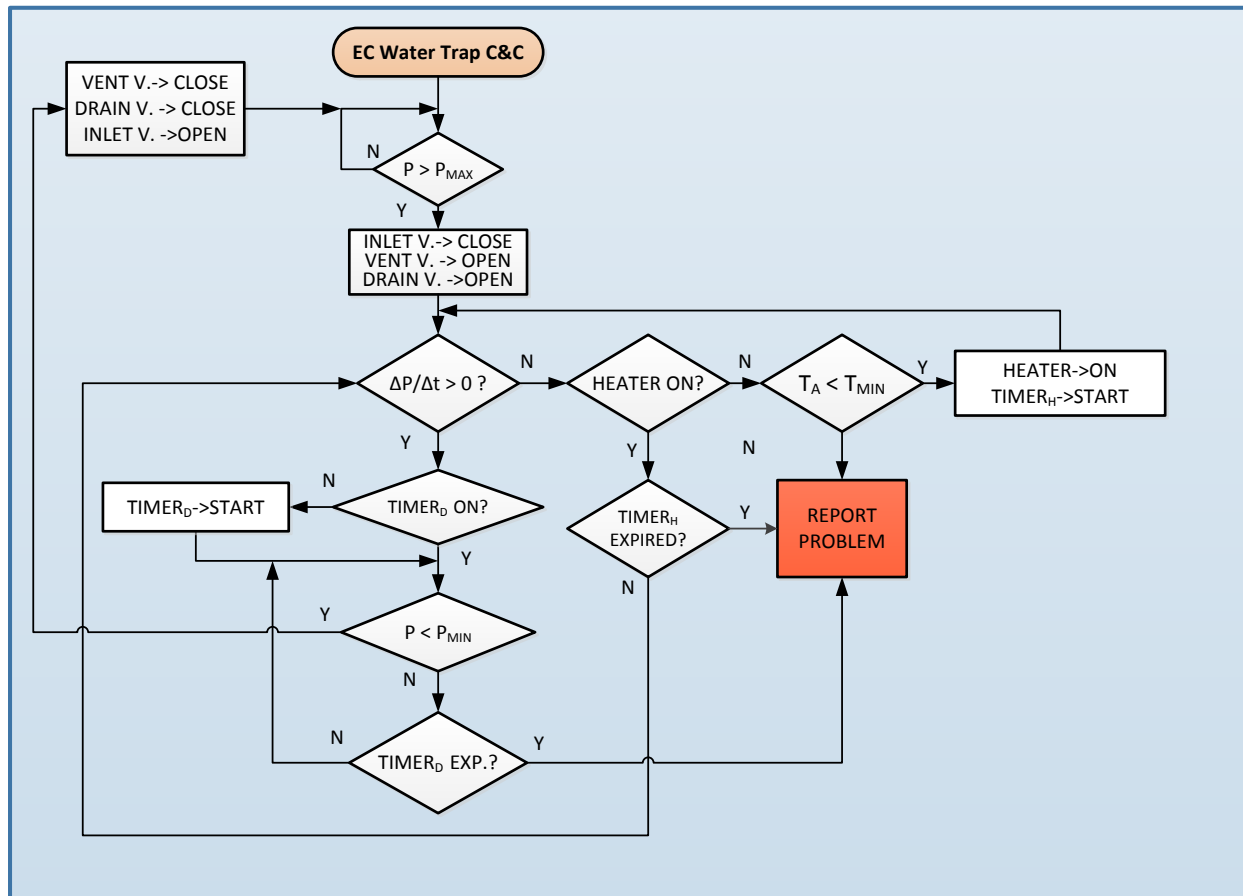

Title: NEON Command, Control, and Configuration: Eddy-covariance Turbulent Exchange Subsystem		Date: 0/26/2016
NEON Doc. #: NEON.DOC.000456	Author: D. Durden, S. Metzger, J. Taylor, H. Loescher	Revision: A

Figure 5. Flow chart for water trap command and control.

## 6 VACUUM PUMP (CD07150000)

### 6.1 Introduction

During sampling and leak testing modes, a vacuum pump is used to draw an air current through the IRGA sampling cell (Sect. 5.3, Table 9, Table 10). A GAST 2032-101-G644 oil-less rotary vane vacuum pump (GAST, accessed 2013) will be used for this purpose (Table 1). Here we describe the configuration, command and control related to the operation of this vacuum pump. The associated SOP document (AD[06]) explains the requirements for deployment and maintenance.

### 6.2 Overview of sensor configuration

DAS (LC) will control the pump speed through controlling the voltage signal sent to the pump. This voltage (0-5 volts) sent to pump will be streamed as L0 DPs and used for post- data process to generate system health flags. 0 volt means pump is stopped. The speed control voltage set point for the pump is 4 volts. Table 17 summarizes the configuration of the vacuum pump.

Table 17. Configuration of the vacuum pump.

Parameter	Default Setting
Power status	On, switchable via PDU

### 6.3 Command and control

NA

#### 6.3.1 Error handling

Switch off vacuum pump before overheating; send trouble ticket to PTR at HQ.

#### 6.3.2 Controls specification

See Sect. 5.3. Additional controls are summarized in Table 18.

Table 18. Truth table to control the vacuum pump.

Control parameter(s)	Condition	Data acquisition system action	Output to CI
$dp_{IRGA}$	$if(dp_{IRGA} \geq 10000 \text{ Pa})$	Switch off vacuum pump, send trouble ticket to PTR	Summarized in Table 9 and Table 10

Title: NEON Command, Control, and Configuration: Eddy-covariance Turbulent Exchange Subsystem		Date: 0/26/2016
NEON Doc. #: NEON.DOC.000456	Author: D. Durden, S. Metzger, J. Taylor, H. Loescher	Revision: A

		at HQ	
--	--	-------	--

## 7 MASS FLOW CONTROLLERS (CA11460000 & 0341500000)

### 7.1 Introduction

Mass flow controllers are used to maintain and monitor a constant flow rate through the IRGA optical cell during sampling and validation configurations (Table 9, Table 10). The Alicat MCRW Series mass flow controller (Alicat Scientific, 2012) with 20 SLPM body and 20 SLPM full scale range will be used during sampling (Table 1). The Alicat MC Series mass flow controller (Alicat Scientific, 2012) with 5 SLPM full scale range will be used during validation cycles (Table 1). Both mass flow controller will be operated with a data acquisition frequency of 1 Hz. Here, we describe the configuration, command and control related to the operation of these flow controllers. The associated SOP document (AD[06]) explains the requirements for calibration, deployment, maintenance and sensor exchanges.

### 7.2 Overview of sensor configuration

Sensor configuration settings are given in Table 19.

**Table 19.** Sampling and validation mass flow controller configuration settings.

Sampling Mass Flow Controller ( CA11460000)	
Parameter	Default Setting
Interface	RS-232
Baud rate	19200
Input/output	8 data bits, no parity, 1 stop bit, no flow control
Control valve configuration	Downstream valve
Standard conditions for mass flow calculations	NIST standard conditions (293.15 K, 101.325 kPa)
Gas select	Air
PID parameters	Factory setting
Response time	0.1 s
Positioning	Upright
Output frequency	1 Hz
Validation Mass Flow Controller (0341500000)	
Parameter	Default Setting
Interface	RS-232
Baud rate	19200
Input/output	8 data bits, no parity, 1 stop bit, no flow control
Control valve configuration	Upstream valve
Standard conditions for mass flow calculations	NIST standard conditions (293.15 K,

<i>Title:</i> NEON Command, Control, and Configuration: Eddy-covariance Turbulent Exchange Subsystem		<i>Date:</i> 0/26/2016
<i>NEON Doc. #:</i> NEON.DOC.000456	<i>Author:</i> D. Durden, S. Metzger, J. Taylor, H. Loescher	<i>Revision:</i> A

	101.325 kPa)
Gas select	Air
PID parameters	Factory setting
Response time	0.1 s
Positioning	Upright
Output frequency	1 Hz

### 7.3 Command and control

NA

#### 7.3.1 Error handling

NA

#### 7.3.2 Controls specification

See Sect. 5.3.

## 8 GAS CYLINDER PRESSURE SENSORS (CA07160000 &CA07170000)

### 8.1 Introduction

Pressure sensors are used to monitor (i) the pressure in the gas cylinders and (ii) the supply-side pressure after the pressure regulator for gas delivery to the associated sensors and (iii) line pressure (Table 9, Table 10). At this time, the Omega PX-319 series sensors (Omega, accessed 2013) will be used for these purposes (Table 1). Here, we describe the configuration, command and control related to the operation of this pressure sensor. A description of how sensor readings shall be converted to pressure units is provided in the associated ATBD (AD[05]). The associated SOP document (AD[06]) explains the requirements for calibration, field deployment, and maintenance.

### 8.2 Overview of sensor configuration

The acquisition rate from this sensor shall be 1 Hz. The default sensor configuration settings are given in Table 20. In the hut, the gas cylinder locations follow the specified layout in AD [8]. Locations from number 9 to 16 are assigned to the cylinders used for profile system.

Gas cylinders will be swapped by field techs when the gas cylinder pressure drops below 400 psig (2758 kPa). The gas concentration inside the cylinder may change during a cylinder swap. Therefore, the timestamp when the cylinder is swapped will be provided by field techs. The gas concentration and uncertainties for each cylinder will be provided by CVAL.

Title: NEON Command, Control, and Configuration: Eddy-covariance Turbulent Exchange Subsystem		Date: 0/26/2016
NEON Doc. #: NEON.DOC.000456	Author: D. Durden, S. Metzger, J. Taylor, H. Loescher	Revision: A

L0 data for the gas concentration and associated uncertainty for gas cylinders (DGD: 0353710000) will be extracted from CVAL XML file. It can be found in Appendix 9.1.

**Table 20.** Default sensor configuration settings for the gas cylinder pressure sensor.

Parameter	Setting
Excitation	Analog, 9–30 V
Output	Analog, 0.004–0.02 A

### 8.3 Command and control

NA

#### 8.3.1 Error handling

NA

#### 8.3.2 Gas cylinder pressure sensor controls specification

**Table 21.** Truth table for gas cylinder pressure.

Control parameter(s)	Condition	Data acquisition system action	Flag output to CI as L0 DP
Cylinder pressure	Cylinder pressure < 400 psig (2758 kPa)	Generate trouble ticket and send to field technician to swap gas cylinder	None

Title: NEON Command, Control, and Configuration: Eddy-covariance Turbulent Exchange Subsystem		Date: 0/26/2016
NEON Doc. #: NEON.DOC.000456	Author: D. Durden, S. Metzger, J. Taylor, H. Loescher	Revision: A

## 9 APPENDIX

### 9.1 List of Level 0 data product

DGD Agile PN	DPName	DPNumber	fieldName	description	Acquisition frequency (Hz)	dataType	units
CD00370010	soni	NEON.DOM.SITE.DP0.00007.001.01927.HOR.VER.000	veloXaxs	Linear velocity (velo) of wind in 3-D sonic anemometer along-axis direction (Xaxs), positive backward	20 Hz	real	metersPerSecond
	soni	NEON.DOM.SITE.DP0.00007.001.01928.HOR.VER.000	veloYaxs	Linear velocity (velo) of wind in 3-D sonic anemometer cross-axis direction (Yaxs), positive right	20 Hz	real	metersPerSecond
	soni	NEON.DOM.SITE.DP0.00007.001.01929.HOR.VER.000	veloZaxs	Linear velocity (velo) of wind in 3-D sonic anemometer vertical-axis direction (Zaxs), positive upwards	20 Hz	real	metersPerSecond
	soni	NEON.DOM.SITE.DP0.00007.001.01308.HOR.VER.000	veloSoni	Linear velocity (velo) of sound (Soni)	20 Hz	real	metersPerSecond
	soni	NEON.DOM.SITE.DP0.00007.001.01930.HOR.VER.000	idx	Index value (idx)	20 Hz	integer	NA
	soni	NEON.DOM.SITE.DP0.00007.001.01931.HOR.VER.000	diag16	Diagnostic value (diag), output as a 16 bit integer Bit assignment according to NEON.DOC.000807 (LO prime processing ATBD)	20 Hz	integer	NA

Title: NEON Command, Control, and Configuration: Eddy-covariance Turbulent Exchange Subsystem		Date: 0/26/2016
NEON Doc. #: NEON.DOC.000456	Author: D. Durden, S. Metzger, J. Taylor, H. Loescher	Revision: A

TBD	soni	NEON.DOM.SITE.DP0.00007.001.01927.HOR.VER.000	veloXaxs	Linear velocity (velo) of wind in 3-D sonic anemometer along-axis direction (Xaxs), positive backward	20 Hz	real	metersPerSecond
	soni	NEON.DOM.SITE.DP0.00007.001.01928.HOR.VER.000	veloYaxs	Linear velocity (velo) of wind in 3-D sonic anemometer cross-axis direction (Yaxs), positive right	20 Hz	real	metersPerSecond
	soni	NEON.DOM.SITE.DP0.00007.001.01929.HOR.VER.000	veloZaxs	Linear velocity (velo) of wind in 3-D sonic anemometer vertical-axis direction (Zaxs), positive upwards	20 Hz	real	metersPerSecond
	soni	NEON.DOM.SITE.DP0.00007.001.01308.HOR.VER.000	veloSoni	Linear velocity (velo) of sound (Soni)	20 Hz	real	metersPerSecond
	soni	NEON.DOM.SITE.DP0.00007.001.01930.HOR.VER.000	idx	Index value (idx)	20 Hz	integer	NA
	soni	NEON.DOM.SITE.DP0.00007.001.01931.HOR.VER.000	diag16	Diagnostic value (diag), output as a 16 bit integer Bit assignment according to NEON.DOC.000807 (LO prime processing ATBD)	20 Hz	integer	NA
	soni	NEON.DOM.SITE.DP0.00007.001.01936.HOR.VER.000	tempBloc	Temperature (temp) of the instrument block (Bloc) measured by platinum resistance thermometers (heated 3-D sonic anemometer only)	?	real	celsius

Title: NEON Command, Control, and Configuration: Eddy-covariance Turbulent Exchange Subsystem		Date: 0/26/2016
NEON Doc. #: NEON.DOC.000456	Author: D. Durden, S. Metzger, J. Taylor, H. Loescher	Revision: A

	soni	NEON.DOM.SITE.DP0.00007.001.01933.HOR.VER.000	tempArmTop	Temperature (temp) of the arm (Arm) top zone (Top) measured by platinum resistance thermometers (heated 3-D sonic anemometer only)	?	real	celsius
	soni	NEON.DOM.SITE.DP0.00007.001.01934.HOR.VER.000	tempArmBot	Temperature (temp) of the arm (Arm) bottom (Bot) zone measured by platinum resistance thermometers (heated 3-D sonic anemometer only)	?	real	celsius
	soni	NEON.DOM.SITE.DP0.00007.001.01932.HOR.VER.000	tempTranTop	Temperature (temp) of the transducer (Tran) top zone (Top) measured by platinum resistance thermometers (heated 3-D sonic anemometer only)	?	real	celsius
	soni	NEON.DOM.SITE.DP0.00007.001.01935.HOR.VER.000	tempTranBot	Temperature (temp) of the transducer (Tran) bottom zone (Bot) measured by platinum resistance thermometers (heated 3-D sonic anemometer only)	?	real	celsius
CD00370100	soniAmrs	NEON.DOM.SITE.DP0.00010.001.02200.HOR.VER.000	acceXaxs	Linear acceleration (acce) in attitude and motion reference system along-axis	40 Hz	real	metersPerSecondSquared



Title: NEON Command, Control, and Configuration: Eddy-covariance Turbulent Exchange Subsystem		Date: 0/26/2016
NEON Doc. #: NEON.DOC.000456	Author: D. Durden, S. Metzger, J. Taylor, H. Loescher	Revision: A

				direction (Xaxs), positive forward			
soniAmrs	NEON.DOM.SITE.DP0.00010.001.02201.HOR.VER.000	acceYaxs		Linear acceleration (acce) in attitude and motion reference system along-axis direction (Yaxs), positive left	40 Hz	real	metersPerSecondSquared
soniAmrs	NEON.DOM.SITE.DP0.00010.001.02202.HOR.VER.000	acceZaxs		Linear acceleration (acce) in attitude and motion reference system vertical-axis direction (Zaxs), positive upwards	40 Hz	real	metersPerSecondSquared
soniAmrs	NEON.DOM.SITE.DP0.00010.001.02203.HOR.VER.000	acceXaxsFree		Linear acceleration (acce) in attitude and motion reference system along-axis direction (Xaxs), positive forward, after subtraction of acceleration due to earth's gravity (free)	40 Hz	real	metersPerSecondSquared
soniAmrs	NEON.DOM.SITE.DP0.00010.001.02204.HOR.VER.000	acceYaxsFree		Linear acceleration (acce) in attitude and motion reference system cross-axis direction (Yaxs), positive left, after subtraction of acceleration due to earth's gravity (free)	40 Hz	real	metersPerSecondSquared

Title: NEON Command, Control, and Configuration: Eddy-covariance Turbulent Exchange Subsystem		Date: 0/26/2016
NEON Doc. #: NEON.DOC.000456	Author: D. Durden, S. Metzger, J. Taylor, H. Loescher	Revision: A

	soniAmrs	NEON.DOM.SITE.DP0.00010.001.02205.HOR.VER.000	acceZaxsFree	Linear acceleration (acce) in attitude and motion reference system vertical-axis direction (Zaxs), positive upwards, after subtraction of acceleration due to earth's gravity (free)	40 Hz	real	metersPerSecondSquared
	soniAmrs	NEON.DOM.SITE.DP0.00010.001.02206.HOR.VER.000	omegYaxs	Angular velocity (omeg) around the attitude and motion reference system cross-axis (Yaxs), positive in clockwise direction, synonymous with pitch rate	40 Hz	real	radiansPerSecond
	soniAmrs	NEON.DOM.SITE.DP0.00010.001.02207.HOR.VER.000	omegXaxs	Angular velocity (omeg) around the attitude and motion reference system along-axis (Xaxs), positive in clockwise direction, synonymous with roll rate	40 Hz	real	radiansPerSecond
	soniAmrs	NEON.DOM.SITE.DP0.00010.001.02208.HOR.VER.000	omegZaxs	Angular velocity (omeg) around the attitude and motion reference system vertical-axis (Zaxs), positive in clockwise direction, synonymous with yaw rate	40 Hz	real	radiansPerSecond

Title: NEON Command, Control, and Configuration: Eddy-covariance Turbulent Exchange Subsystem		Date: 0/26/2016
NEON Doc. #: NEON.DOC.000456	Author: D. Durden, S. Metzger, J. Taylor, H. Loescher	Revision: A

	soniAmrs	NEON.DOM.SITE.DP0.00010.001.02209.HOR.VER.000	thetYaxs	Angle (thet) around the attitude and motion reference system cross-axis (Yaxs), positive in clockwise direction, synonymous with pitch angle	40 Hz	real	degree
	soniAmrs	NEON.DOM.SITE.DP0.00010.001.02210.HOR.VER.000	thetXaxs	Angle (thet) around the attitude and motion reference system along-axis (Xaxs), positive in clockwise direction, synonymous with roll angle	40 Hz	real	degree
	soniAmrs	NEON.DOM.SITE.DP0.00010.001.02211.HOR.VER.000	thetZaxs	Angle (thet) around the attitude and motion reference system vertical-axis (Zaxs), positive in clockwise direction, synonymous with yaw angle	40 Hz	real	degree
	soniAmrs	NEON.DOM.SITE.DP0.00010.001.01930.HOR.VER.000	idx	Index value (idx)	20 Hz	integer	NA
	soniAmrs	NEON.DOM.SITE.DP0.00010.001.01931.HOR.VER.000	diag32	Diagnostic value (diag), output as 32-bit integer Bit assignment according to NEON.DOC.000807 (L0 prime processing ATBD)	40 Hz	integer	NA
CD00380100	irga	NEON.DOM.SITE.DP0.00016.001.02178.HOR.VER.000	tempCellIn	Temperature (temp) of the optical cell (Cell) inlet (In) thermocouple	20Hz	real	celsius

Title: NEON Command, Control, and Configuration: Eddy-covariance Turbulent Exchange Subsystem		Date: 0/26/2016
NEON Doc. #: NEON.DOC.000456	Author: D. Durden, S. Metzger, J. Taylor, H. Loescher	Revision: A

irga	NEON.DOM.SITE.DP0.00016.001.02179.HOR.VER.000	tempCellOut	Temperature (temp) of the optical cell (Cell) outlet (Out) thermocouple	20Hz	real	celsius
irga	NEON.DOM.SITE.DP0.00016.001.01936.HOR.VER.000	tempBloc	Temperature (temp) of the instrument block (Bloc) thermocouple	20Hz	real	celsius
irga	NEON.DOM.SITE.DP0.00016.001.02180.HOR.VER.000	presAtmBox	Pressure (pres), measured as atmospheric (Atm) pressure of the control box (Box), synonymous with absolute pressure or total pressure (at sea level the standard atmospheric pressure is 101.325 kPa)	20Hz	real	kilopascal
irga	NEON.DOM.SITE.DP0.00016.001.02181.HOR.VER.000	presGageCell	Pressure (pres), measured as differential against ambient pressure, synonymous with gage (Gage) pressure (at sea level the gage pressure equals total pressure minus 101.325 kPa), between the optical cell (Cell) and the control box	20Hz	real	kilopascal
irga	NEON.DOM.SITE.DP0.00016.001.02182.HOR.VER.000	pwrH2OSamp	Power (pwr) of the water vapor (H2O) signal in the absorption band used for sampling	20Hz	real	watt

Title: NEON Command, Control, and Configuration: Eddy-covariance Turbulent Exchange Subsystem		Date: 0/26/2016
NEON Doc. #: NEON.DOC.000456	Author: D. Durden, S. Metzger, J. Taylor, H. Loescher	Revision: A

				(Samp)			
irga	NEON.DOM.SITE.DP0.00016.001.02183.HOR.VER.000	pwrH2ORef	Power (pwr) of the water vapor (H2O) signal in the absorption band used for reference (Ref)	20Hz	real	watt	
irga	NEON.DOM.SITE.DP0.00016.001.02184.HOR.VER.000	asrpH2O	Electromagnetic absorptance (asrp) in the water vapor (H2O) absorption band	20Hz	real	dimensionless	
irga	NEON.DOM.SITE.DP0.00016.001.02185.HOR.VER.000	rhoMoleH2O	Density (rho) on molar basis (Mole) of water vapor (H2O), synonymous with number density	20Hz	real	millimolesPerCubicMeter	
irga	NEON.DOM.SITE.DP0.00016.001.02186.HOR.VER.000	fdMoleH2O	Dry mole fraction (fd) on molar basis (Mole) of water vapor (H2O), synonymous with mixing ratio	20Hz	real	millimolesPerMole	
irga	NEON.DOM.SITE.DP0.00016.001.02187.HOR.VER.000	pwrCO2Samp	Power (pwr) of the carbon dioxide (CO2) signal in the absorption band used for sampling (Samp)	20Hz	real	watt	
irga	NEON.DOM.SITE.DP0.00016.001.02188.HOR.VER.000	pwrCO2Ref	Power (pwr) of the carbon dioxide (CO2) signal in the absorption band used for	20Hz	real	watt	

Title: NEON Command, Control, and Configuration: Eddy-covariance Turbulent Exchange Subsystem		Date: 0/26/2016
NEON Doc. #: NEON.DOC.000456	Author: D. Durden, S. Metzger, J. Taylor, H. Loescher	Revision: A

				reference (Ref)			
irga	NEON.DOM.SITE.DP0.00016.001.02189.HOR.VER.000	asrpCO2	Electromagnetic absorptance (asrp) in the carbon dioxide (CO2) absorption band	20Hz	real	dimensionless	
irga	NEON.DOM.SITE.DP0.00016.001.02190.HOR.VER.000	rhoMoleCO2	Density (rho) on molar basis (Mole) of carbon dioxide (CO2), synonymous with number density	20Hz	real	millimolesPerCubicMeter	
irga	NEON.DOM.SITE.DP0.00016.001.02191.HOR.VER.000	fdMoleCO2	Dry mole fraction (fd) on molar basis (Mole) of carbon dioxide (CO2), synonymous with mixing ratio	20Hz	real	micromolesPerMole	
irga	NEON.DOM.SITE.DP0.00016.001.01930.HOR.VER.000	idx	Index value (idx)	20Hz	integer	NA	
irga	NEON.DOM.SITE.DP0.00016.001.01931.HOR.VER.000	diag	Diagnostic value (diag)	20Hz	integer	NA	
irga	NEON.DOM.SITE.DP0.00016.001.02192.HOR.VER.000	diag2	Diagnostic value (diag) number 2 (2; sync clocks)	20Hz	integer	NA	

Title: NEON Command, Control, and Configuration: Eddy-covariance Turbulent Exchange Subsystem		Date: 0/26/2016
NEON Doc. #: NEON.DOC.000456	Author: D. Durden, S. Metzger, J. Taylor, H. Loescher	Revision: A

	irga	NEON.DOM.SITE.DP0.00016.001.02193.HOR.VER.000	poteCool	Electric potential (pote) at the cooler (Cool)	20Hz	real	volt
	irga	NEON.DOM.SITE.DP0.00016.001.02194.HOR.VER.000	ssiCO2	Signal strength indicator (ssi) for the carbon dioxide (CO2) absorption band	20Hz	real	percent
	irga	NEON.DOM.SITE.DP0.00016.001.02195.HOR.VER.000	ssiH2O	Signal strength indicator (ssi) for the water vapor (H2O) absorption band	20Hz	real	percent
CA11460000	irgaMfcSamp	NEON.DOM.SITE.DP0.00012.001.01952.HOR.VER.000	frtSet0	Flow rate (frt) set point (Set) at National Institute of Standards and Technology standard conditions (0; temperature 293.15 K, pressure 101.325 kPa), synonymous with mass flow rate set point	1 Hz	real	litersPerMinute
	irgaMfcSamp	NEON.DOM.SITE.DP0.00012.001.01951.HOR.VER.000	frt0	Flow rate (frt) at National Institute of Standards and Technology standard conditions (0; temperature 293.15 K, pressure 101.325 kPa), synonymous with mass flow rate	1 Hz	real	litersPerMinute

Title: NEON Command, Control, and Configuration: Eddy-covariance Turbulent Exchange Subsystem		Date: 0/26/2016
NEON Doc. #: NEON.DOC.000456	Author: D. Durden, S. Metzger, J. Taylor, H. Loescher	Revision: A

	irgaMfcSamp	NEON.DOM.SITE.DP0.00012.001.01950.HOR.VER.000	frt	Flow rate (frt) at site temperature and pressure, synonymous with volumetric flow rate	1 Hz	real	litersPerMinute
	irgaMfcSamp	NEON.DOM.SITE.DP0.00012.001.01948.HOR.VER.000	presAtm	Pressure (pres), measured as atmospheric (Atm) pressure, synonymous with absolute pressure or total pressure (at sea level the standard atmospheric pressure is 101.325 kPa)	1 Hz	real	kilopascal
	irgaMfcSamp	NEON.DOM.SITE.DP0.00012.001.01949.HOR.VER.000	temp	Temperature (temp)	1 Hz	real	celsius
0341500000	irgaMfcVali	NEON.DOM.SITE.DP0.00015.001.01952.HOR.VER.000	frtSet0	Flow rate (frt) set point (Set) at National Institute of Standards and Technology standard conditions (0; temperature 293.15 K, pressure 101.325 kPa), synonymous with mass flow rate set point	1 Hz	real	litersPerMinute
	irgaMfcVali	NEON.DOM.SITE.DP0.00015.001.01951.HOR.VER.000	frt0	Flow rate (frt) at National Institute of Standards and Technology standard conditions (0; temperature 293.15 K, pressure 101.325 kPa), synonymous with mass	1 Hz	real	litersPerMinute



Title: NEON Command, Control, and Configuration: Eddy-covariance Turbulent Exchange Subsystem		Date: 0/26/2016
NEON Doc. #: NEON.DOC.000456	Author: D. Durden, S. Metzger, J. Taylor, H. Loescher	Revision: A

				flow rate			
	irgaMfcVali	NEON.DOM.SITE.DP0.00015.001.01950.HOR.VER.000	frt	Flow rate (frt) at site temperature and pressure, synonymous with volumetric flow rate	1 Hz	real	litersPerMinute
	irgaMfcVali	NEON.DOM.SITE.DP0.00015.001.01948.HOR.VER.000	presAtm	Pressure (pres), measured as atmospheric (Atm) pressure, synonymous with absolute pressure or total pressure (at sea level the standard atmospheric pressure is 101.325 kPa)	1 Hz	Real	kilopascal
	irgaMfcVali	NEON.DOM.SITE.DP0.00015.001.01949.HOR.VER.000	temp	Temperature (temp)	1 Hz	Real	celsius
CD06450000	irgaSndLeakHeat	NEON.DOM.SITE.DP0.00008.001.02197.HOR.VER.000	qfTrapIn	Qualifying flag (qf) indicating the status of the water trap (Trap) inlet (In) solenoid (0 = open [default], 1 = close)	0.2 Hz	integer	NA

Title: NEON Command, Control, and Configuration: Eddy-covariance Turbulent Exchange Subsystem		Date: 0/26/2016
NEON Doc. #: NEON.DOC.000456	Author: D. Durden, S. Metzger, J. Taylor, H. Loescher	Revision: A

	irgaSndLeakHe at	NEON.DOM.SITE.DP0.00008.001.02198.HOR.VER.000	qfTrapOut	Qualifying flag (qf) indicating the status of the water trap (Trap) vent (Out) solenoid (0 = close [default], 1 = open)	0.2 Hz	Integer	NA
	irgaSndLeakHe at	NEON.DOM.SITE.DP0.00008.001.02199.HOR.VER.000	qfLeak	Qualifying flag (qf) indicating the status of the sampling line leak (Leak) test master solenoid (0 = leak test not being performed [default], 1 = leak test being performed)	0.2 Hz	Integer	NA

<i>Title:</i> NEON Command, Control, and Configuration: Eddy-covariance Turbulent Exchange Subsystem		<i>Date:</i> 0/26/2016
<i>NEON Doc. #:</i> NEON.DOC.000456	<i>Author:</i> D. Durden, S. Metzger, J. Taylor, H. Loescher	<i>Revision:</i> A

	irgaSndLeakHeat	NEON.DOM.SITE.DP0.00008.001.02221.HOR.VER.000	qfHeatSoni	Qualifying flag (qf) indicating the status of the heater (Heat; heated 3-D sonic (Soni) anemometer only; 0 = off [default], 1 = on)	0.2 Hz	Integer	NA
	irgaSndLeakHeat	NEON.DOM.SITE.DP0.00008.001.02222.HOR.VER.000	qfHeatTube	Qualifying flag (qf) indicating the status of the heater (Heat) for the intake tube (Tube; 0 = heater on [default], 1 = heater off)	0.2 Hz	Integer	NA

Title: NEON Command, Control, and Configuration: Eddy-covariance Turbulent Exchange Subsystem		Date: 0/26/2016
NEON Doc. #: NEON.DOC.000456	Author: D. Durden, S. Metzger, J. Taylor, H. Loescher	Revision: A

	irgaSndLeakHeat	NEON.DOM.SITE.DP0.00008.001.02223.HOR.VER.000	qfHeatCap	Qualifying flag (qf) indicating the status of the heater (Heat) for the rain cap (Cap; 0 = heater off [default], 1 = heater on)	0.2 Hz	Integer	NA
	irgaSndLeakHeat	NEON.DOM.SITE.DP0.00008.001.02224.HOR.VER.000	qfHeatVali	Qualifying flag (qf) indicating the status of the heater (Heat) for the validation gas (Vali) path (0 = heater off [default], 1 = heater on)	0.2 Hz	integer	NA
CA07190000	irgaPresTrap	NEON.DOM.SITE.DP0.00036.001.01948.HOR.VER.000	presAtm	Pressure (pres), measured as atmospheric (Atm) pressure, synonymous with absolute pressure or total pressure (at sea level the standard atmospheric pressure is	1 Hz	real	kilopascal

Title: NEON Command, Control, and Configuration: Eddy-covariance Turbulent Exchange Subsystem		Date: 0/26/2016
NEON Doc. #: NEON.DOC.000456	Author: D. Durden, S. Metzger, J. Taylor, H. Loescher	Revision: A

				101.325 kPa)			
CA07160000	irgaPresValiLine	NEON.DOM.SITE.DP0.00037.001.02196.HOR.VER.000	presGage	Pressure (pres), measured as differential against ambient pressure, synonymous with gage (Gage) pressure (at sea level the gage pressure equals total pressure minus 101.325 kPa)	1 Hz	real	kilopascal
CA07160000	irgaPresValiRegOut	NEON.DOM.SITE.DP0.00035.001.02196.HOR.VER.000	presGage	Pressure (pres), measured as differential against ambient pressure, synonymous with gage (Gage) pressure (at sea level the gage pressure equals total pressure minus 101.325 kPa)	1 Hz	real	kilopascal
CA07170000	irgaPresValiRegIn	NEON.DOM.SITE.DP0.00034.001.02196.HOR.VER.000	presGage	Pressure (pres), measured as differential against ambient pressure, synonymous with gage (Gage) pressure (at sea level the gage pressure equals total pressure minus 101.325 kPa)	1 Hz	real	kilopascal
CD07150000	irgaPump	NEON.DOM.SITE.DP0.00116.001.02351.HOR.VER.000	pumpVoltage	Voltage provided to pump	0.2 Hz	real	volt

Title: NEON Command, Control, and Configuration: Eddy-covariance Turbulent Exchange Subsystem		Date: 0/26/2016
NEON Doc. #: NEON.DOC.000456	Author: D. Durden, S. Metzger, J. Taylor, H. Loescher	Revision: A

CD06640003	irgaSndValiHut	NEON.DOM.SITE.DP0.00011.001.02212.HOR.VER.000	qfGas1	Qualifying flag (qf) indicating validation gas (Gas) number 1 solenoid status (1; 0 = close [default], 1 = open)	0.2 Hz	integer	NA
	irgaSndValiHut	NEON.DOM.SITE.DP0.00011.001.02213.HOR.VER.000	qfGas2	Qualifying flag (qf) indicating validation gas (Gas) number 2 solenoid status (2; 0 = close [default], 1 = open)	0.2 Hz	integer	NA
	irgaSndValiHut	NEON.DOM.SITE.DP0.00011.001.02214.HOR.VER.000	qfGas3	Qualifying flag (qf) indicating validation gas (Gas) number 3 solenoid status (3; 0 = close [default], 1 = open)	0.2 Hz	integer	NA
	irgaSndValiHut	NEON.DOM.SITE.DP0.00011.001.02215.HOR.VER.000	qfGas4	Qualifying flag (qf) indicating validation gas (Gas) number 4 solenoid status (4; 0 = close [default], 1 = open)	0.2 Hz	integer	NA
	irgaSndValiHut	NEON.DOM.SITE.DP0.00011.001.02216.HOR.VER.000	qfGas5	Qualifying flag (qf) indicating validation gas (Gas) number 5 solenoid status (5; 0 = close [default], 1 = open)	0.2 Hz	integer	NA
CD06640004	irgaSndValiNema	NEON.DOM.SITE.DP0.00009.001.02212.HOR.VER.000	qfGas1	Qualifying flag (qf) indicating validation gas (Gas) number 1 solenoid status (1; 0 = close [default], 1 = open)	0.2 Hz	integer	NA

Title: NEON Command, Control, and Configuration: Eddy-covariance Turbulent Exchange Subsystem		Date: 0/26/2016
NEON Doc. #: NEON.DOC.000456	Author: D. Durden, S. Metzger, J. Taylor, H. Loescher	Revision: A

	irgaSndValiNe ma	NEON.DOM.SITE.DP0.00009.001.02213.HOR.VER.000	qfGas2	Qualifying flag (qf) indicating validation gas (Gas) number 2 solenoid status (2; 0 = close [default], 1 = open)	0.2 Hz	integer	NA
	irgaSndValiNe ma	NEON.DOM.SITE.DP0.00009.001.02214.HOR.VER.000	qfGas3	Qualifying flag (qf) indicating validation gas (Gas) number 3 solenoid status (3; 0 = close [default], 1 = open)	0.2 Hz	integer	NA
	irgaSndValiNe ma	NEON.DOM.SITE.DP0.00009.001.02215.HOR.VER.000	qfGas4	Qualifying flag (qf) indicating validation gas (Gas) number 4 solenoid status (4; 0 = close [default], 1 = open)	0.2 Hz	integer	NA
	irgaSndValiNe ma	NEON.DOM.SITE.DP0.00009.001.02216.HOR.VER.000	qfGas5	Qualifying flag (qf) indicating validation gas (Gas) number 5 solenoid status (5; 0 = close [default], 1 = open)	0.2 Hz	integer	NA
0353710000	irgaGasCyl	NEON.DOM.SITE.DP0.00117.001.02191.HOR.VER.000	fdMoleCO2	Dry mole fraction (fd) on molar basis (Mole) of carbon dioxide (CO2), synonymous with mixing ratio		real	micromolesPerMole
	irgaGasCyl	NEON.DOM.SITE.DP0.00117.001.02324.HOR.VER.000	d13CO2	Measure of the ratio of stable isotopes 13C:12C in CO2, relative to the Vienna Pee Dee Belemnite		real	permill

<i>Title:</i> NEON Command, Control, and Configuration: Eddy-covariance Turbulent Exchange Subsystem		<i>Date:</i> 0/26/2016
<i>NEON Doc. #:</i> NEON.DOC.000456	<i>Author:</i> D. Durden, S. Metzger, J. Taylor, H. Loescher	<i>Revision:</i> A

	irgaGasCyl	NEON.DOM.SITE.DP0.00117.001.02318.HOR.VER.000	fdMole12CO2	Dry molar fraction (fd) of 12CO2 in the air		real	micromolesPerMole
	irgaGasCyl	NEON.DOM.SITE.DP0.00117.001.02320.HOR.VER.000	fdMole13CO2	Dry molar fraction (fd) of 13CO2 in the air		real	micromolesPerMole



<i>Title:</i> NEON Command, Control, and Configuration: Eddy-covariance Turbulent Exchange Subsystem		<i>Date:</i> 0/26/2016
<i>NEON Doc. #:</i> NEON.DOC.000456	<i>Author:</i> D. Durden, S. Metzger, J. Taylor, H. Loescher	<i>Revision:</i> A

Title: NEON Command, Control, and Configuration: Eddy-covariance Turbulent Exchange Subsystem		Date: 0/26/2016
NEON Doc. #: NEON.DOC.000456	Author: D. Durden, S. Metzger, J. Taylor, H. Loescher	Revision: A

## 9.2 Validation and verification Tests – attitude and motion reference system

Aside from the default operation, the Xsens MTi-300-AHRS attitude and motion reference system (Sect. 4) shall also be used for validation and verification tests on a case-by-case basis. Such tests are relevant to (i) assess the influence of boom motions on the wind measurement (Sect. 3), and (ii) detect vibrations within the sensitive frequency range (140–160 Hz) of the H<sub>2</sub>O, CO<sub>2</sub> concentration measurement (Sect. 4). For this purpose it shall be possible to operate the MTi-300-AHRS with a data acquisition frequency of 400 Hz. Table 22 specifies the configuration settings of the MTi-300-AHRS during validation and verification test.

**Table 22.** Validation and verification configuration settings for the Xsens MTi-300-AHRS.

Parameter	Setting
Sensor/Body coordinate system	forward-left-up (sensor-default)
Sensor/Reference coordinate system	east-north-up (ENU, sensor default)
Sensor/Misalignment	no misalignment
Sensor/GPS lever arm	no displacement
Heading reference	-
Motion profile	low mag_dep
Data Output/Status	status word
Data Output/Inertial Data	rate of turn, acceleration, free acceleration
Data Output/Orientation	Euler Angles
output frequency	400 Hz
output configuration	trigger
Protocol	MTI low-level
serial communication	RS-232
Baudrate	115200
data bits	8
Parity	none
stop bits	1
flow control	disabled
Captured L0 DPs	Table 5

## 9.3 Acronyms

Acronym	Description
3-D	Three-dimensional
ATBD	Algorithm theoretical basis document
C <sup>3</sup>	Command, control, and configuration document

Title: NEON Command, Control, and Configuration: Eddy-covariance Turbulent Exchange Subsystem		Date: 0/26/2016
NEON Doc. #: NEON.DOC.000456	Author: D. Durden, S. Metzger, J. Taylor, H. Loescher	Revision: A

Acronym	Description
CVAL	NEON calibration, validation, and audit laboratory
DAS	Data acquisition system
DGD	Data generating device
DP	Data product
EC-TES	Eddy-covariance turbulent exchange subsystem
ENG	Engineering (NEON project team)
FIU	Fundamental instrument unit (NEON project team)
HQ	Headquarters
ID	Identification
L0–L4	Level 0 through level 4 data products
NA	Not available/not applicable
NTP	Network Time Protocol
PDU	Power distribution unit
PN	Part number
PT	Project team
PTR	Problem tracking and resolution
QA/QC	Quality Assurance/Quality Control
SONIC	Ultrasonic anemometer/thermometer
SOP	Standard operations procedure
TBD	To be determined
TIS	Terrestrial Instrument System

#### 9.4 Functions

Function	Description
d	Differential
max	Maximum
min	Minimum
$\bar{X}$	Short-term (e.g., 30 min) arithmetic mean of atmospheric quantity $X$

#### 9.5 Parameters

Parameter	Description	Numeric value	Units
$T_{zero}$	Absolute zero temperature	-273.15	°C

Title: NEON Command, Control, and Configuration: Eddy-covariance Turbulent Exchange Subsystem		Date: 0/26/2016
NEON Doc. #: NEON.DOC.000456	Author: D. Durden, S. Metzger, J. Taylor, H. Loescher	Revision: A

## 9.6 Subscripts

Subscript	Description
1...N	Numeric identifier
air	Air (sum of dry air and water vapor)
drain	Water drain
IRGA	Infrared gas analyzer
m	Measurement
max	Maximum
min	Minimum
trap	Water trap

## 9.7 Variables

Variable	Description	Units
$acc$	Boom arm acceleration	$m\ s^{-2}$
$b$	Individual bit of binary data	Dimensionless (0 or 1)
$c$	Speed of sound in air	$m\ s^{-1}$
$dp_{IRGA}$	IRGA pressure drop	kPa
$\alpha, \beta$	Pitch and roll rotation angles	Decimal degree
$\theta$	Sonic anemometer pitch	Decimal degree
$i$	Running index	Dimensionless (count)
$p$	Pressure	$Pa \equiv kg\ m^{-1}\ s^{-2}$
$t$	Time	s
$T$	Absolute temperature	K
$T_{H_2O}$	Dew point temperature	K
$u, v, w$	Along-, cross- and vertical wind speed	$m\ s^{-1}$
$\phi$	Sonic anemometer roll	Decimal degree
$x, y, z$	Along-, cross- and vertical axes of a Cartesian coordinate system	Dimensionless
$X, Y$	Placeholder for atmospheric quantities	Depending on unit of atmospheric quantity
$\Psi$	Wind direction	Decimal degree

<i>Title:</i> NEON Command, Control, and Configuration: Eddy-covariance Turbulent Exchange Subsystem		<i>Date:</i> 0/26/2016
<i>NEON Doc. #:</i> NEON.DOC.000456	<i>Author:</i> D. Durden, S. Metzger, J. Taylor, H. Loescher	<i>Revision:</i> A

<b>Variable</b>	<b>Description</b>	<b>Units</b>
$\Psi_0$	Wind direction offset	Decimal degree

<i>Title:</i> NEON Command, Control, and Configuration: Eddy-covariance Turbulent Exchange Subsystem		<i>Date:</i> 0/26/2016
<i>NEON Doc. #:</i> NEON.DOC.000456	<i>Author:</i> D. Durden, S. Metzger, J. Taylor, H. Loescher	<i>Revision:</i> A

## 10 BIBLIOGRAPHY

Alicat Scientific: Precision gas mass flow controllers operating manual, Alicat Scientific, Tucson, Arizona, USA, 83, 2012.

Campbell Scientific: CSAT3 three dimensional sonic anemometer instruction manual, Campbell Scientific, Logan, USA, 72, 2011.

Foken, T.: Micrometeorology, Springer, Berlin, Heidelberg, 306 pp., 2008.

GAST: 23-series oil-less vacuum pumps and compressors operation and maintenance manual, GAST, Benton Harbor, Michigan, USA, 8, accessed 2013.

LI-COR Inc.: LI-7200 CO<sub>2</sub>/H<sub>2</sub>O analyzer instruction manual, LI-COR Inc., Lincoln, Nebraska, USA, 194, 2013.

Mori, Y.: Evaluation of Several Single-Pass Estimators of the Mean and the Standard-Deviation of Wind Direction, *J Clim Appl Meteorol*, 25, 1387-1397, doi:10.1175/1520-0450(1986)025<1387:EOSPEO>2.0.CO;2, 1986.

Omega: PX-309 series all stainless steel pressure transducer, Omega, Stamford, Connecticut, USA, 6, accessed 2013.

Xsens Technologies: MTi User Manual, Xsens Technologies, Culver City, USA, 83, 2014.

## 11 CHANGELOG

Revision A, S. Metzger et al., Initial Release.